

NEW GAME REGISTRATION

**REGISTERING YOUR NEW GAME ENTITLES YOU TO AN EXTENDED WARRANTY*
ADD 3 MONTHS TO THE WARRANTY OF THIS GAME BY COMPLETING AND
SUBMITTING, BY FAX OR MAIL, THIS FORM.**

Game Name (one game per form):	Date:
Game Serial Number (located on the back of the cabinet):	Game Location Type Please Check One: <input type="checkbox"/> Family Fun Center <input type="checkbox"/> Sports Bar <input type="checkbox"/> Bar <input type="checkbox"/> Restaurant <input type="checkbox"/> Laundromat <input type="checkbox"/> Movie Theatre <input type="checkbox"/> Mall <input type="checkbox"/> Other (please specify)
Game Owner/Operator Company Name:	
Game Owner/Operator Address:	
Game Owner/Operator City/State/Zip:	
Game Owner/Operator Phone Number:	
Game Owner/Operator Fax Number:	
Game Owner/Operator E-Mail Address:	
Game Location Name and Address:	

***NOTE: Extended warranty only applies if ALL boxes on this form are complete.
One game per form. Extended warranty does not apply to used or close-out games.**



Bay Tek Games Inc.
1077 East Glenbrook Dr.
Pulaski, WI 54162
Fax: 920.822.8936
Phone: 920.822.3951
www.baytekgames.com

**We Aspire To Be The Best
In The World At
Developing And Manufacturing
Coin Operated Games For Our Customers.**



INSTALLATION INFORMATION

Game Serial Number
(Located on the back of the cabinet, see figure below.)

Date of Installation

Installed by

Bay Tek Games Inc.
1077 East Glenbrook Dr.
Pulaski, WI 54162
www.baytekgames.com
E-Mail: service@baytekgames.com

Service: 920.822.3951 EXT. 1102
Parts: 920.822.3951 EXT. 1101
Fax: 920.822.8936
Service Fax: 920.822.1496
Sales: 920.822.3951

SUITABLE FOR INDOOR USE ONLY

Model: AAGM-1234

Software Version: 5-678

Game Serial Number: 9-1234

PCB Serial Number: 567,789

Manufacture Date: 7/07/2007

Inspected By: X.X.

~110-120 VAC
50-60 Hz
2 AMPS

AMUSEMENT
MACHINE



www.baytekgames.com





Join our exclusive
Service First Network

To keep you up to date on the latest information,
early notification of parts specials, technical bulletins,
updates on retro fit parts, software upgrades,
and much more!

If you are not already a member,
sign up for this free service today at:
www.baytekgames.com

SERVICE FIRST NETWORK
CONTACT INFO

Fax directly to service department:

(920) 822-1496
8 A.M. - 5 P.M. CST
MON. - FRI.

Comments / Questions:
(920) 822-3951 ext. 1101
8 A.M. - 5 P.M. CST
MON. - FRI.

Email :
service@baytekgames.com



Operators distinguish Smokin Token as one of the great redemption success stories, and are now able to share in that unprecedented success for yet another generation.

Smokin Token has been taken to the EXTREME!

Smokin Token Extreme™ is a dual player fast coin game exciting for all ages. Player releases token and is awarded tickets for any target hit **AND** the wheel rises up to reveal bonus targets worth double tickets! Player wins the big Extreme Bonus when they hit a bonus target twice before the wheel descends to its original position. Loaded with edgy graphics, LED chase lights, adjustable bonus settings, standard electronics, and a high energy audio package, your players are sure to love this piece!



SAFETY PRECAUTIONS

DANGER

DO NOT perform repairs or maintenance on this game with the power ON. Unplug the unit from the wall outlet or shut off the power at the power strip located inside the game cabinet.

WARNING

Use of flammable substances can cause severe burns or serious injury. Always use NON-FLAMMABLE solvents for cleaning. DO NOT use gasoline, kerosene, or thinners.

CAUTION

Lifting heavy objects can cause back, neck, or other injuries. Be sure adequate lifting and moving devices are available when unloading, unpacking, and moving this game.

ATTENTION



Game power must be OFF before adjusting any of the programming selections.

INSPECTING THE GAME

Inspect the game for any damage, loose, or missing parts. If damage is found please contact the carrier first. Then contact Bay Tek Games at 920.822.3951 or e-mail at service@baytekgames.com to order replacement parts.

SERVICE CONNECTIONS/POWER REQUIREMENTS

All Bay Tek games are 110V unless specifically ordered 220V.
The game will draw **2-3 AMPS** at start up.
Outlets should be rated for **20 AMPS** or higher.

 **ATTENTION** 

Be sure the electrical power matches the game requirements. See the serial number decal located on the back of the game cabinet.

 **ATTENTION** 

Always plug this game into a grounded circuit.

 **ATTENTION** 

If the supply cord is damaged, it must be replaced by a special cord or assembly available from the manufacturer or its service agent.

AUXILIARY BOARD CABLE PLUG-IN MAP

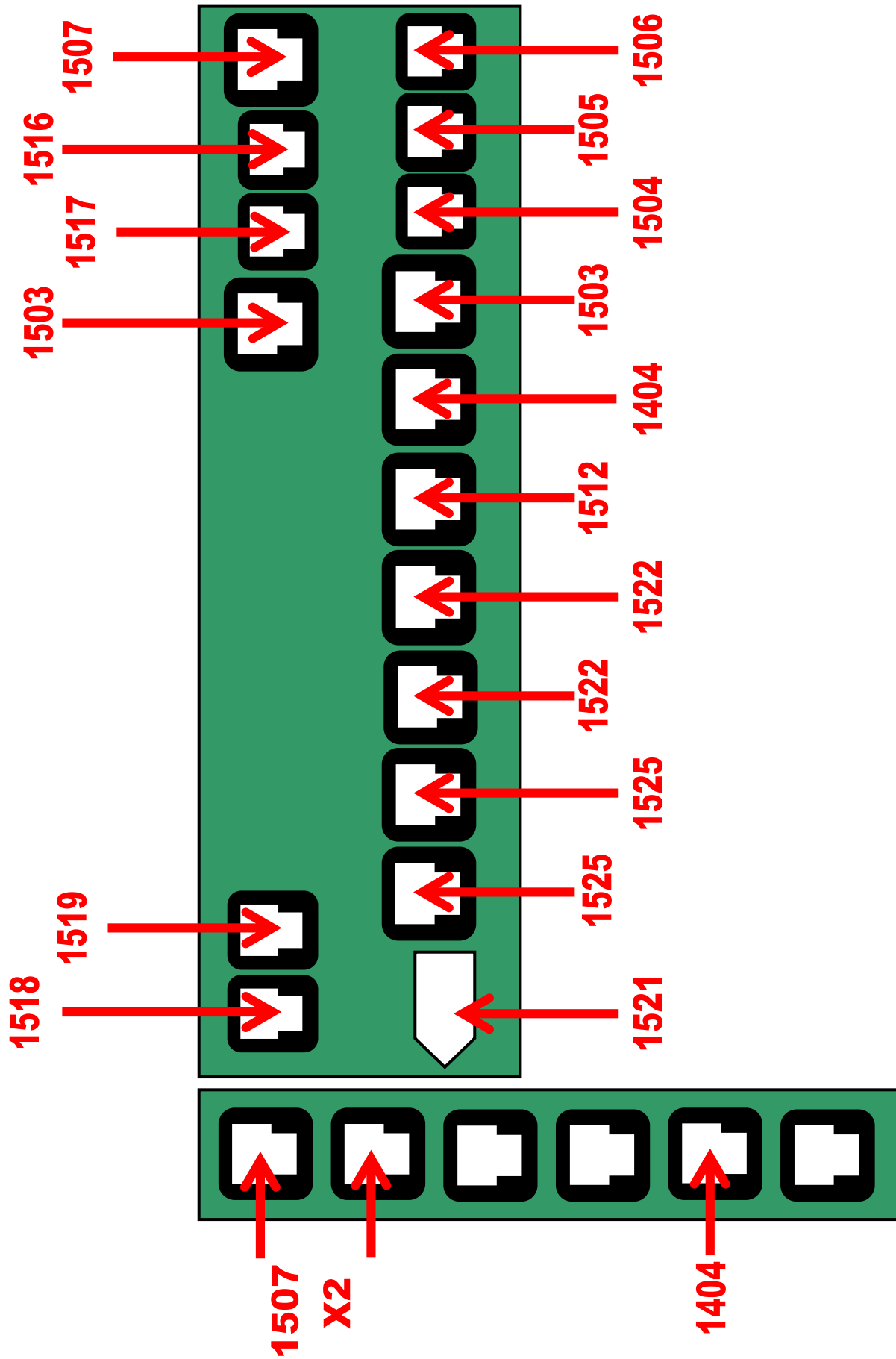

HOW TO ADJUST THE VOLUME

Follow the instructions below to adjust the volume on your Smokin' Token Extreme™

1. Open the two front access doors.

2. Press and hold the red button on the **RIGHT** door.
Release the button when the both "TICKETS" displays read "SND".

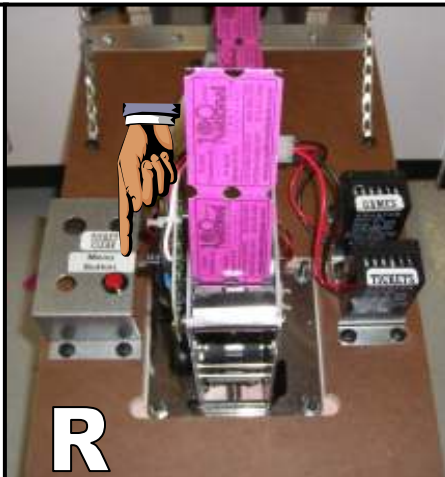

FACTORY DEFAULT = 3

HOW TO ADJUST THE VOLUME

3. The "**EXTREME BONUS**" display will show the current volume setting.

To change the setting press the red button on the **LEFT** door.

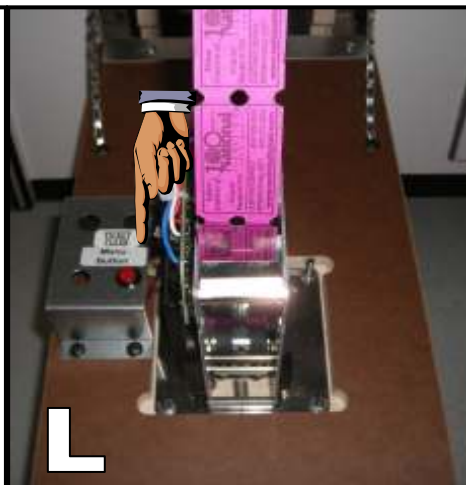

4. To re-enter normal game play press and hold the **LEFT** red button until the displays go normal.

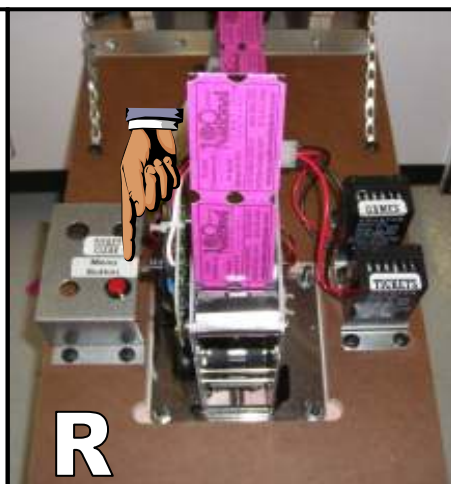

HOW TO VIEW GAME STATISTICS

The Smokin' Token Extreme™ software keeps track of certain statistical information.

Accessing this information is easy and convenient.
We have included a statistic tracking sheet with your game.

Follow the directions on the next few pages to track your games progress.

1. Open both front access doors.

Press and hold the **RIGHT MENU/TICKET CLEAR** button until "nnn" appears on the **LEFT** ticket display.

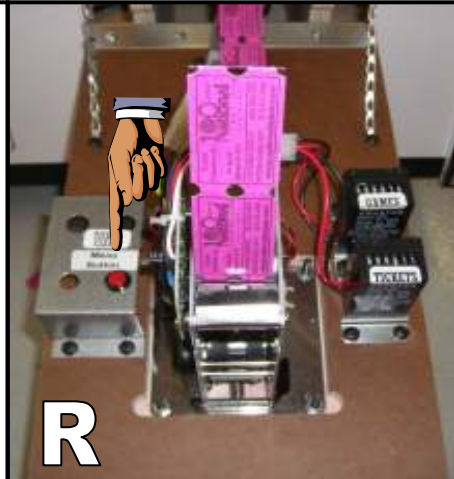

2. The number displayed on the **RIGHT** side **TICKET** display is the statistic number.

The number displayed on the **EXTREME BONUS** display is the statistic value.

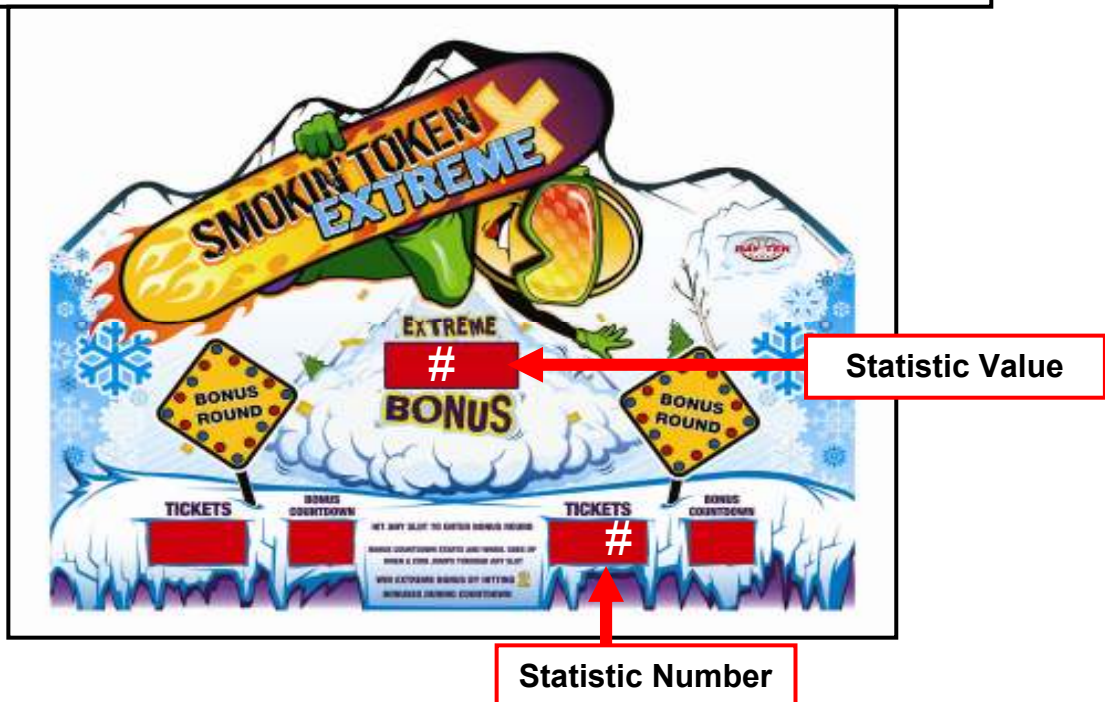

STATISTIC MODE

3. Below is a list of the game statistics and the assigned number that will be displayed on the RIGHT side TICKETS display.

Number on the right side TICKETS display	Statistic assigned to that number
0	Total games played LEFT side
1	Total number played RIGHT side
2	Extreme bonus hits - combined
3	Misses in round 1
4	Misses in round 2
5	Slots 0 and 8 round 1 *
6	Slots 1 and 9 round 1 *
7	Slots 2 and 10 round 1 *
8	Slots 3 and 11 round 1 *
9	Slots 4 and 12 round 1 *
10	Slots 5 and 13 round 1 *
11	Slots 6 and 14 round 1 *
12	Slots 7 and 15 round 1 *
13	Slots 0 and 8 round 2 * (BLUE BONUS)
14	Slots 1 and 9 round 2 *
15	Slots 2 and 10 round 2 *
16	Slots 3 and 11 round 2 *
17	Slots 4 and 12 round 2 * (BLUE BONUS)
18	Slots 5 and 13 round 2 *
19	Slots 6 and 14 round 2 *
20	Slots 7 and 15 round 2 *
21	Tickets dispensed (x100)
22	Tickets Dispensed per coin
* See next page for slot assignments	

ERROR CODES

Below is a list of ERROR codes built into the software.

ERROR	DEFINITION	CAUSE
01	TICKET JAM	Tickets are jammed in the dispenser
Lo	LOW TICKETS	Tickets are low or out
04	SLOT STUCK	There is a blockage in the slot sensor
08	EPROM CHECKSUM ERROR	Please call 920.822.3951 ext. 1101
10	EPROM WRITE ERROR	Please call 920.822.3951 ext. 1101
20	LEVEL NOT FOUND	Please call 920.822.3951 ext. 1101
40	WHEEL RPM ERROR	Please call 920.822.3951 ext. 1101

The above codes will display themselves on the side of the game in which they occur.

Err will be displayed on the **TICKETS** display, the error number will appear on the **BONUS COUNTDOWN** display.



HOW TO CLEAR STORED TICKETS

If the tickets run out before the payout is complete the game will store the remaining amount of tickets due.

Once the ticket tray is refilled the tickets owed will dispense. You can clear the tickets owed in memory in the event the player can not be located by following the directions below.

1. Open the front access door on the side of the game that has the accumulated tickets.

2. Before you load the new ticket pack, press and release the red service button. This will clear the stored tickets in the games memory.

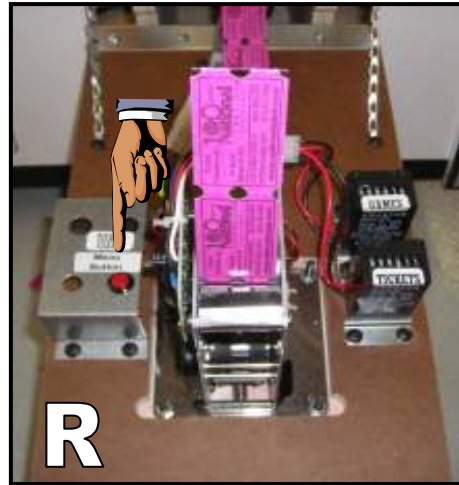
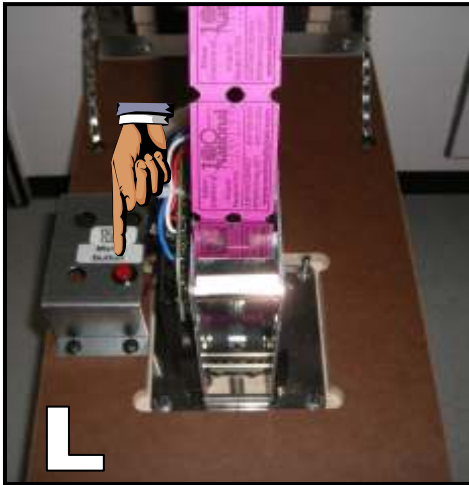

DIP SWITCH ASSIGNMENTS

To change the factory settings you will need to access the two banks of dip switches located on the PCB by removing the back door, see page 15. The switches are located in the upper left corner of the board.



ATTENTION

Game power must be OFF before adjusting any of the programming selections.
 Turn OFF the power strip located inside the game.
 Set the desired dip switches, wait 30 seconds and turn the game back ON.

NOTE

When you look at the dip switches in your game, they appear upside down. The following illustrations reflect that.

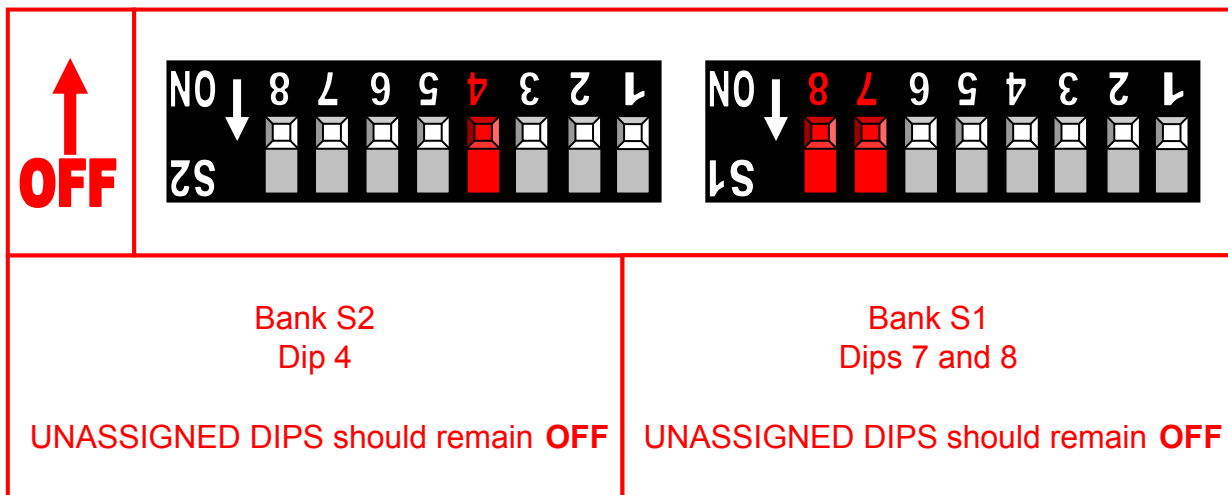

TICKET PAYOUT

BANK S1	DIP 1				
<p>Allows you to choose a Standard Payout or the Fixed Ticket (NJ) payout.</p>	<table border="1" style="width: 100%; border-collapse: collapse;"> <tr> <td style="width: 20%; text-align: center; padding: 5px;">Fixed Ticket ^(NJ) Payout</td> <td style="padding: 5px;"> </td> </tr> <tr> <td style="text-align: center; padding: 5px;">Standard Payout</td> <td style="padding: 5px;"> </td> </tr> </table>	Fixed Ticket ^(NJ) Payout		Standard Payout	
Fixed Ticket ^(NJ) Payout					
Standard Payout					

POWER LOSS MEMORY (NJ)

BANK S1	DIP 2				
<p>In the event that the power is lost during ticket payout the game can store the unpaid amount and continue the payout once power is restored.</p>	<table border="1" style="width: 100%; border-collapse: collapse;"> <tr> <td style="width: 20%; text-align: center; padding: 5px;">Tickets stored</td> <td style="padding: 5px;"> </td> </tr> <tr> <td style="text-align: center; padding: 5px;">Tickets NOT stored</td> <td style="padding: 5px;"> </td> </tr> </table>	Tickets stored		Tickets NOT stored	
Tickets stored					
Tickets NOT stored					

STANDARD TICKET PAYOUT - TABLE 1

BANK S2	DIPS 6, 7, 8
---------	--------------

Each slot scored will pay out the displayed number of tickets.

**Factory
Default**

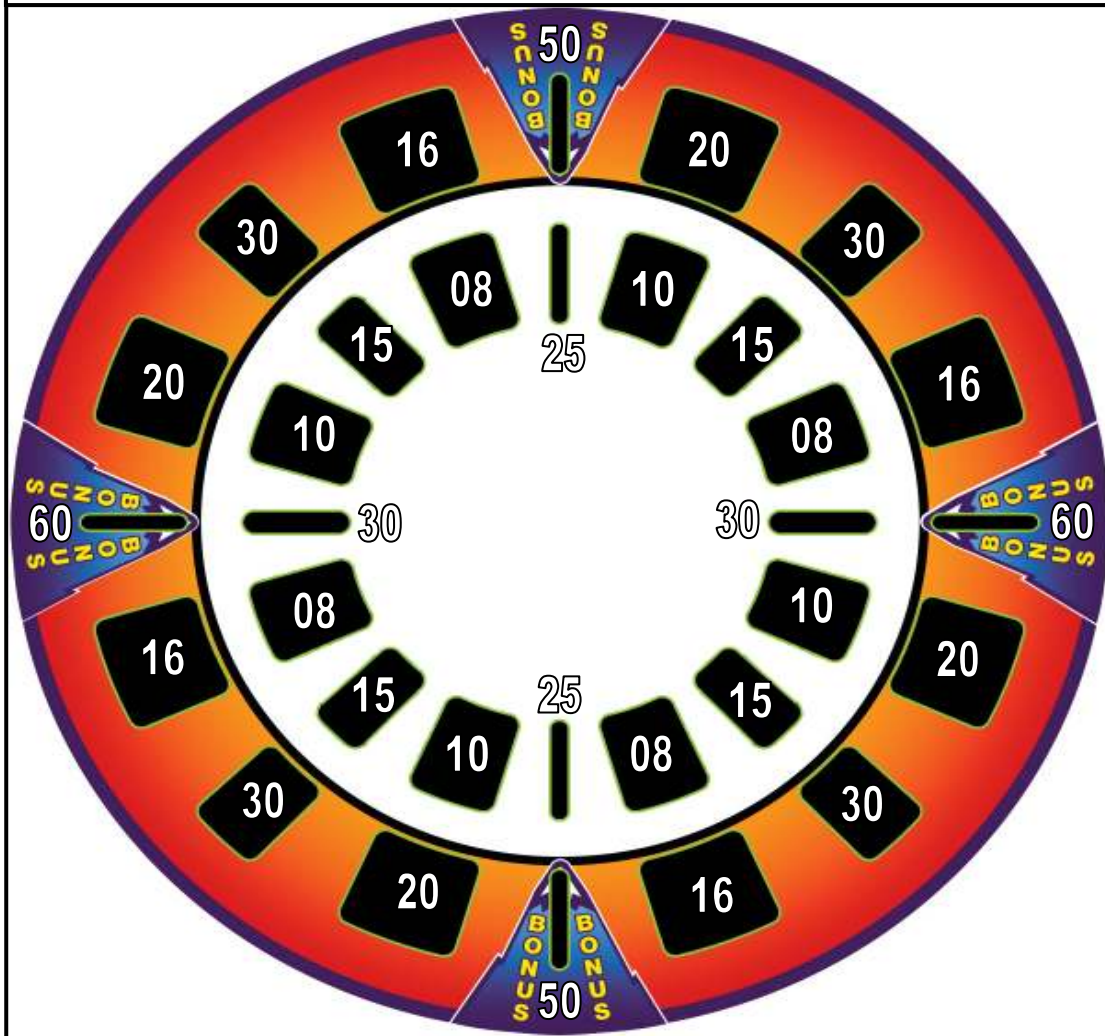
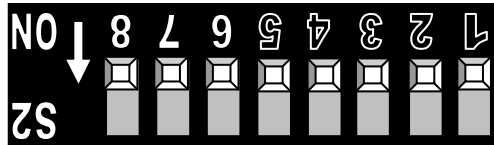

STANDARD TICKET PAYOUT - TABLE 2

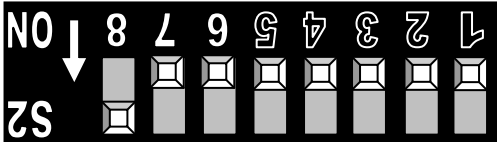
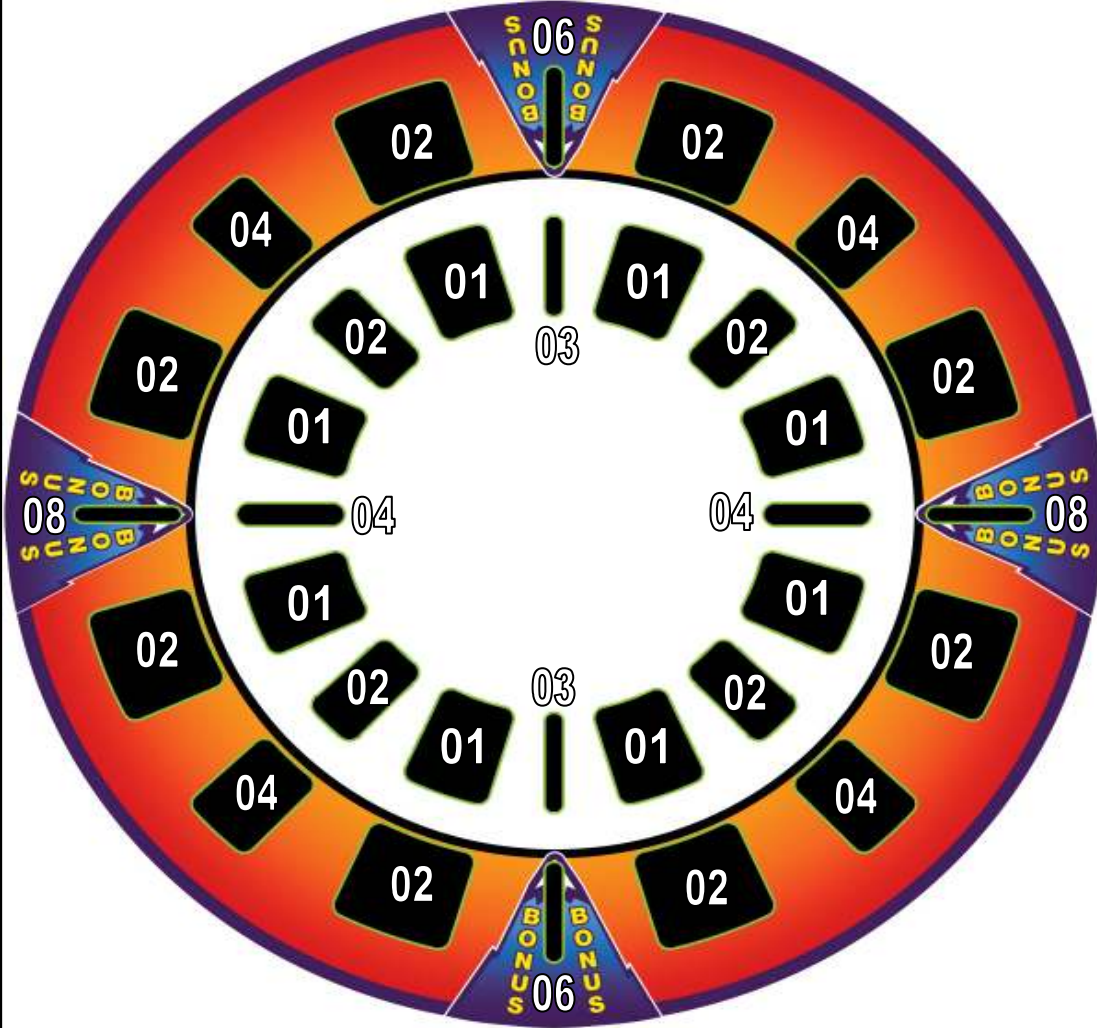
BANK S2	DIPS 6, 7, 8
<p>Each slot scored will pay out the displayed number of tickets.</p>	
	
	

STANDARD TICKET PAYOUT - TABLE 3

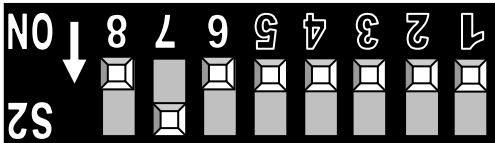
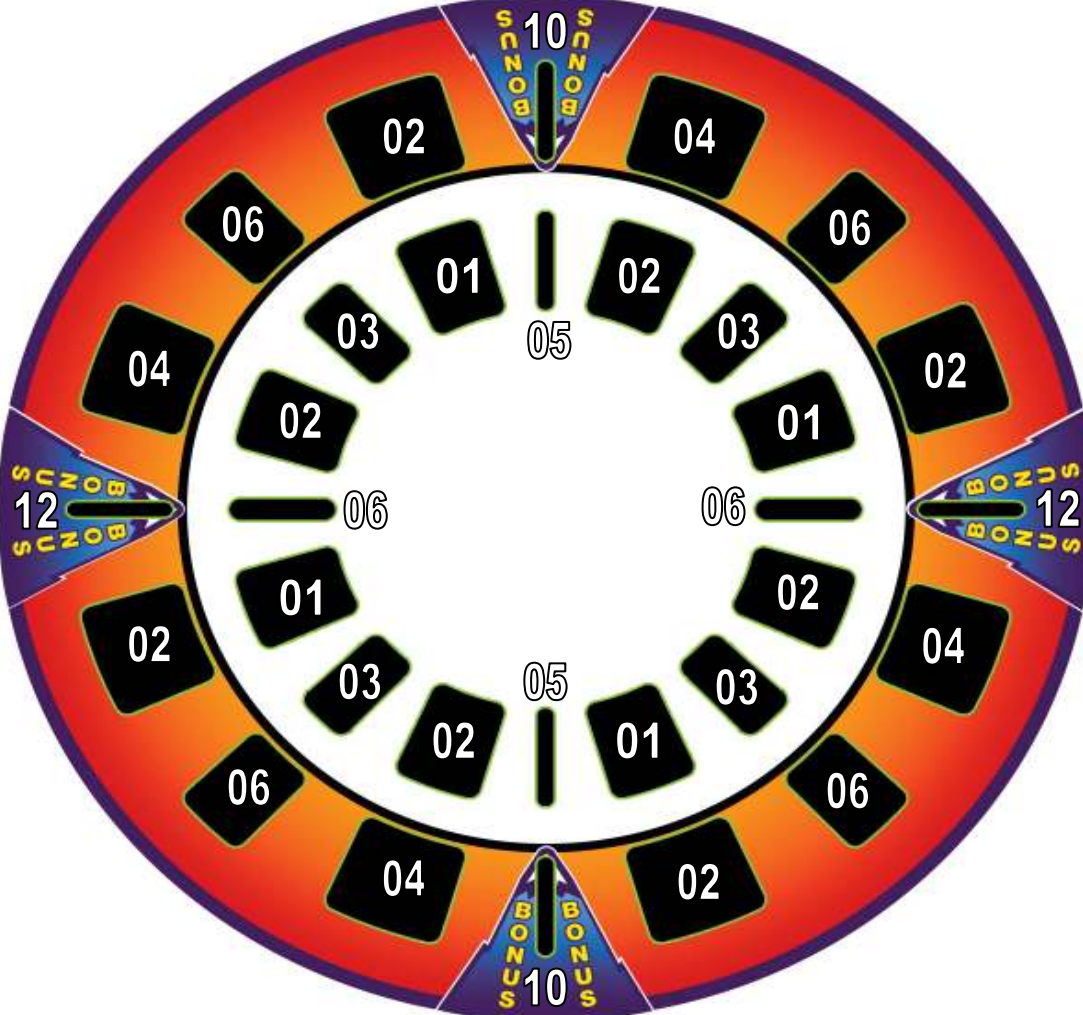
BANK S2	DIPS 6, 7, 8
<p>Each slot scored will pay out the displayed number of tickets.</p>	
	
	

STANDARD TICKET PAYOUT - TABLE 4

BANK S2	DIPS 6, 7, 8
---------	--------------

Each slot scored will pay out the displayed number of tickets.

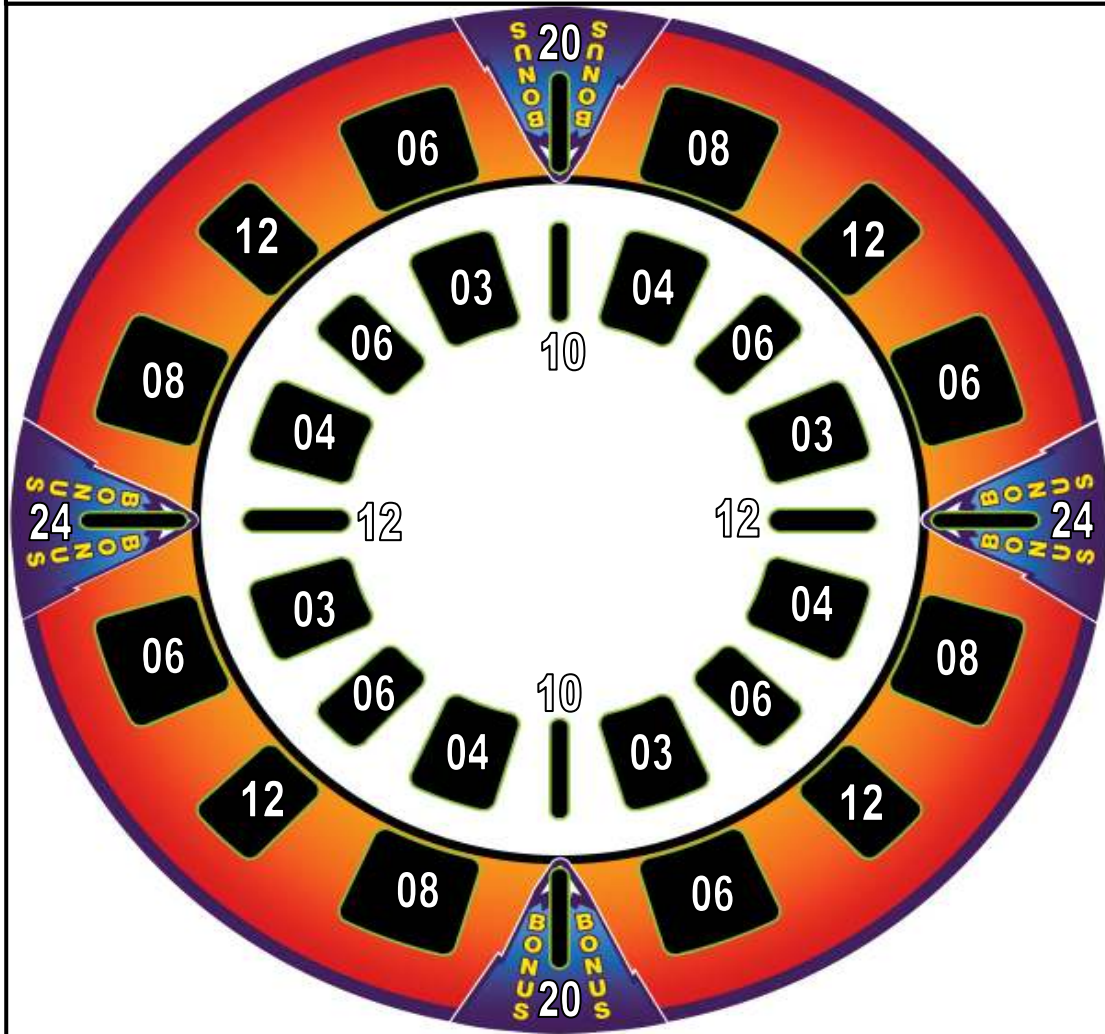
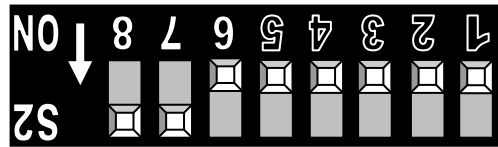

STANDARD TICKET PAYOUT - TABLE 5

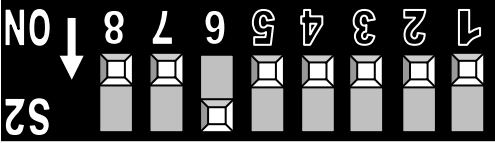
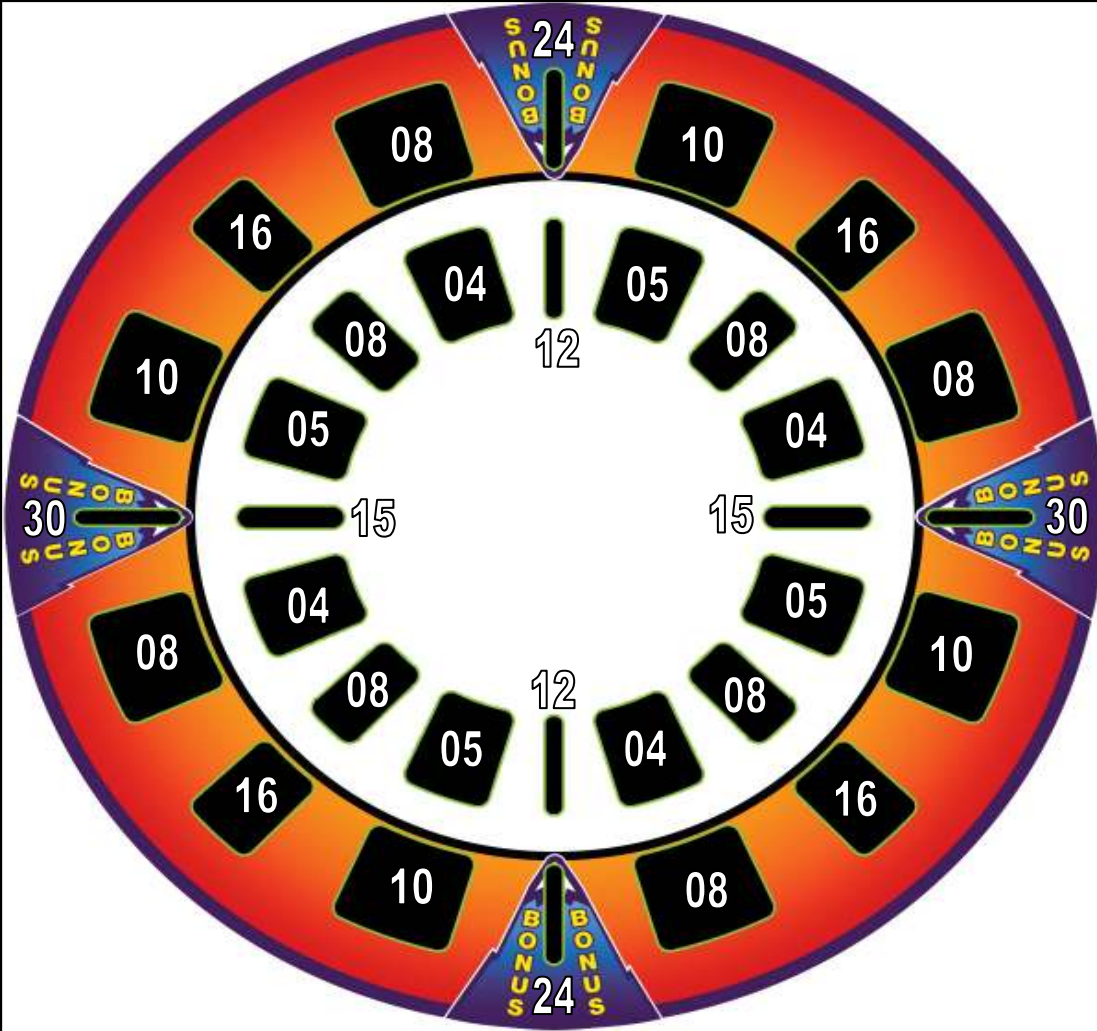
BANK S2	DIPS 6, 7, 8
<p>Each slot scored will pay out the displayed number of tickets.</p>	
	
	

STANDARD TICKET PAYOUT - TABLE 6

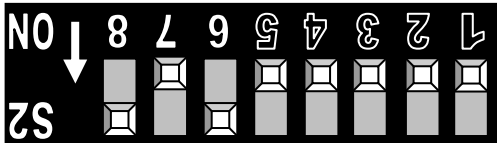
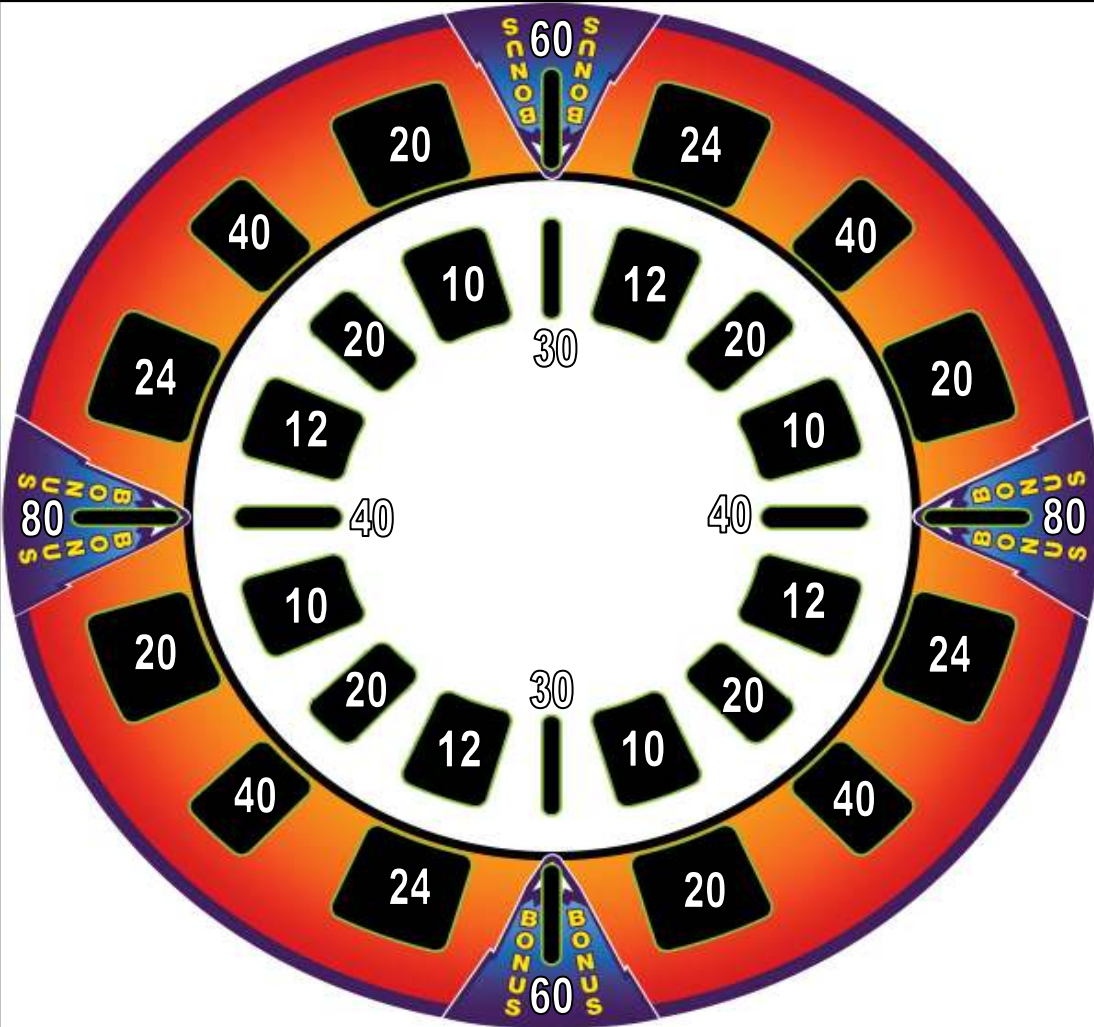
BANK S2	DIPS 6, 7, 8
<p>Each coin entered will pay out the displayed number of tickets.</p>	
	
	

STANDARD TICKET PAYOUT - TABLE 7

BANK S2	DIPS 6, 7, 8
---------	--------------

Each coin entered will pay out the displayed number of tickets.

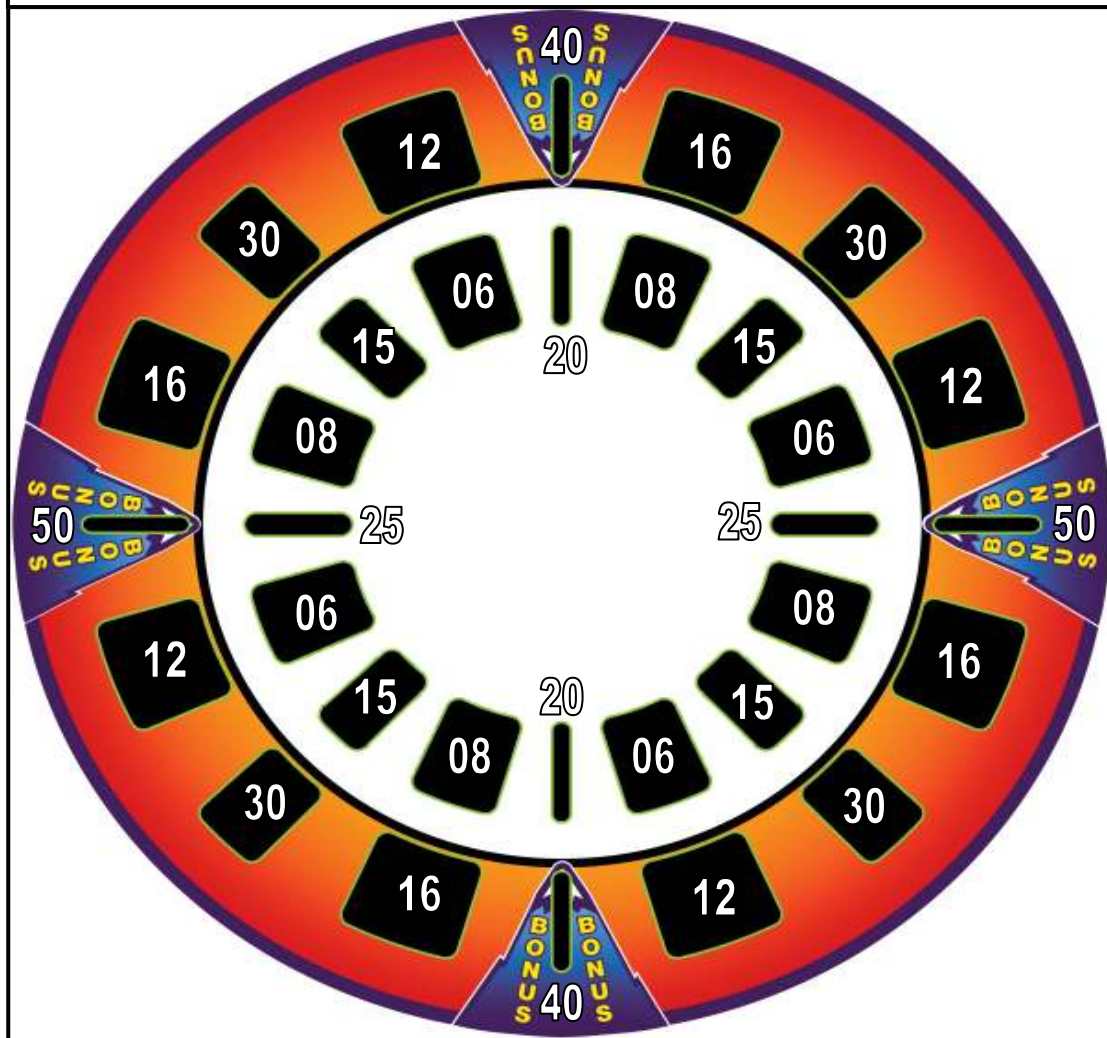
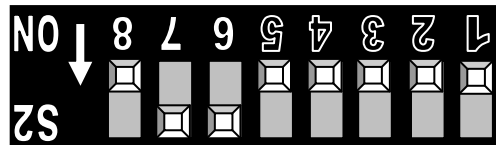

STANDARD TICKET PAYOUT - TABLE 8

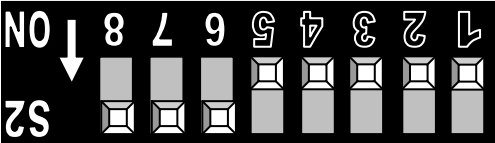
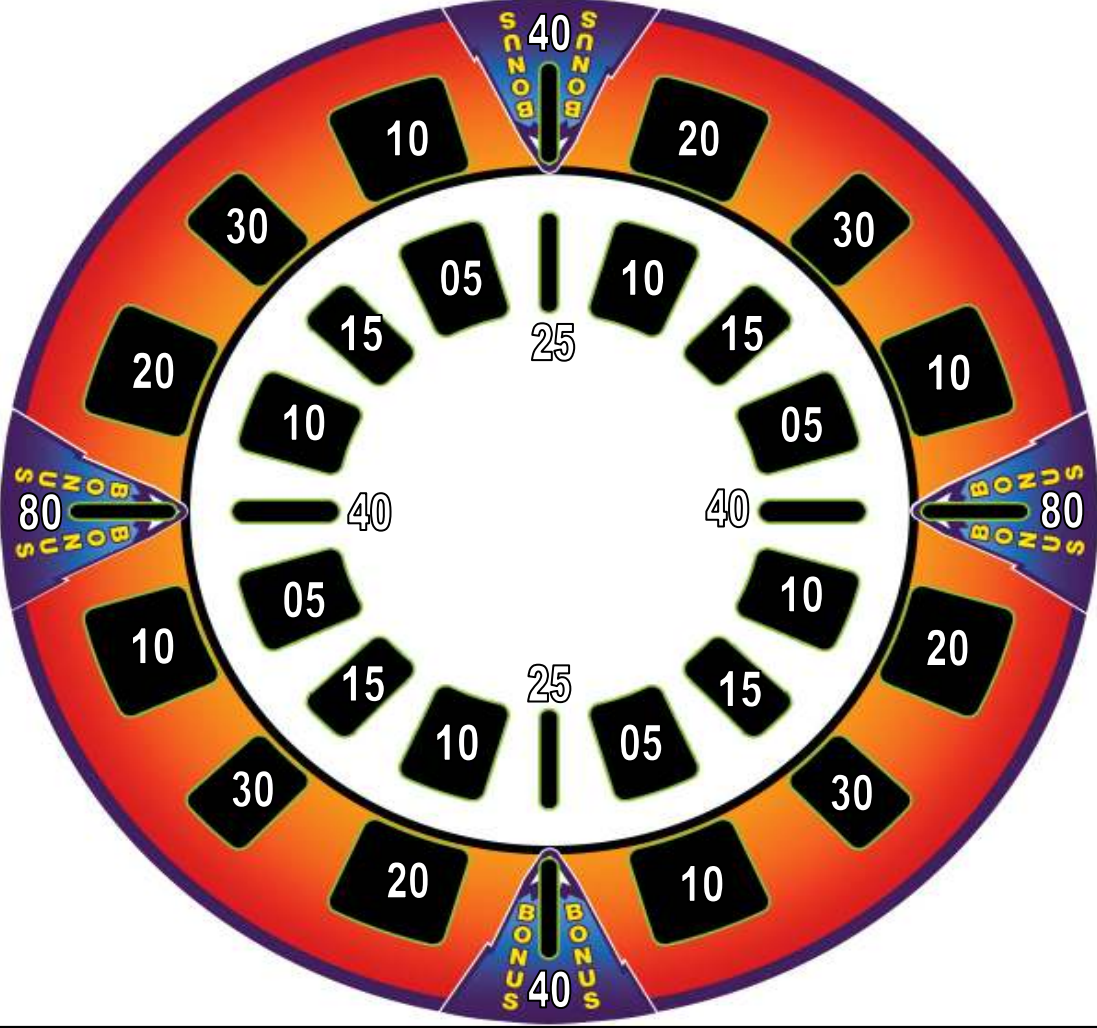
BANK S2	DIPS 6, 7, 8
<p>Each coin entered will pay out the displayed number of tickets.</p>	
	
	

EXTREME BONUS PAYOUT

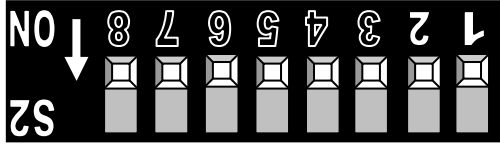
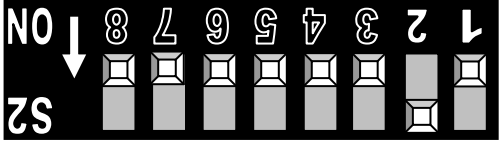
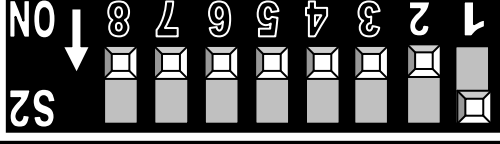
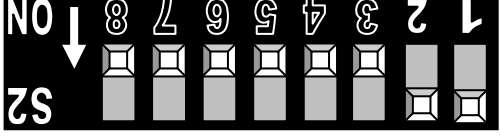
BANK S2	DIPS 1 AND 2	
<p>Allows you to choose a EXTREME BONUS PAYOUT.</p> <p>Use dips 2 and 3 on Bank S2 to set the value.</p> 	<p>1000 Tickets</p> <p><i>Factory Default</i></p>	
	<p>250 Tickets</p>	
	<p>500 Tickets</p>	
	<p>2000 Tickets</p>	

NUMBER OF HITS TO WIN THE EXTREME BONUS

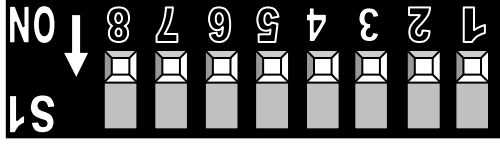
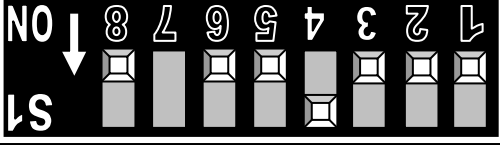
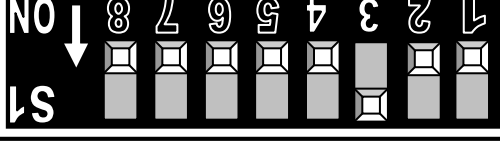
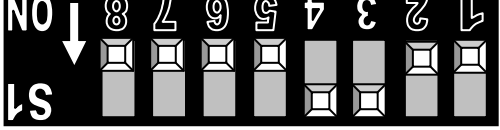
BANK S1	DIPS 3 AND 4	
<p>Allows you to choose how many times the player has to hit the "Blue Bonus" slot, in the time allotted, to win the Extreme Bonus tickets.</p> <p><i>We <u>do not</u> recommend using this to adjust difficulty.</i></p>	<p>2 Hits</p> <p><i>Factory Default</i></p>	
	<p>1 Hit</p>	
	<p>3 Hits</p>	
	<p>4 Hits</p>	

"Blue Bonus"
Slot

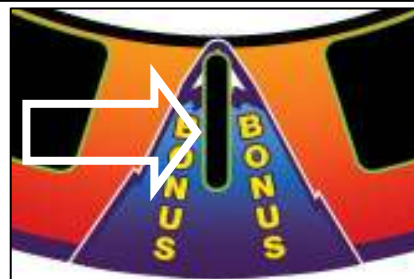

BONUS SHOT TIMER

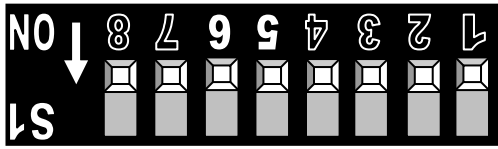
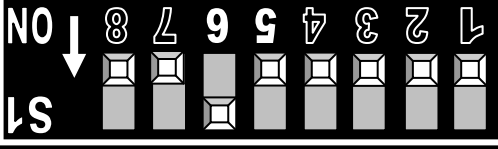
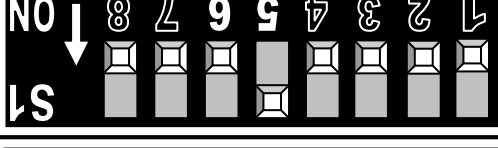
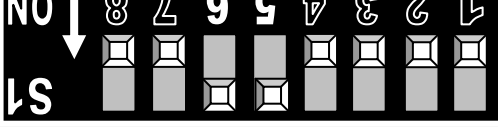
BANK S1	DIPS 5 AND 6	
<p>Allows you to set the number of seconds the player has to hit the "Blue Bonus" slot.</p> <p style="color: green;">We <u>recommend</u> using this to adjust difficulty.</p> <div style="text-align: center; margin-top: 10px;">  </div>	20 Seconds <i>Factory Default</i>	
	7 Seconds	
	14 Seconds	
	25 Seconds	

MERCY TICKET

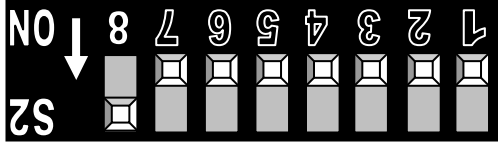
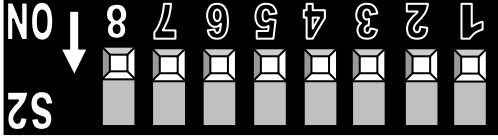
BANK S2	DIP 8	
<p>Allows you to set the game to pay one (1) mercy ticket for every slot missed.</p>	1 Ticket	
	NO Tickets <i>Factory Default</i>	

HALF TICKET PAYOUT

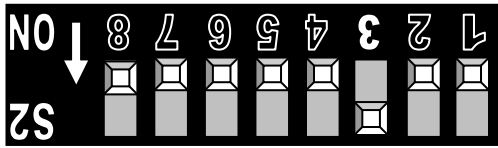
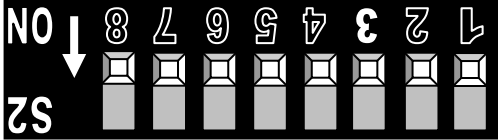
BANK S2	DIP 3	
<p>Allows you to set the game to pay one (1) for every two (2) tickets won.</p>	Half Tickets	
	Full Tickets <i>Factory Default</i>	

FIXED TICKET TABLE (NJ)

BANK S2	DIPS 6, 7, 8	
<p style="text-align: center;">Fixed Ticket (NJ) Ticket payout tables.</p> <p>Each coin entered will pay out the set number of tickets.</p> <p>The player does not need to hit any target slot for payout.</p> <p>Use dips 6, 7, and 8 on Bank 2 to set your value.</p>	5 Tickets	
	6 Tickets	
	7 Tickets	
	8 Tickets	
	9 Tickets	
	10 Tickets	
	11 Tickets	
	12 Tickets	

INSTALLING SOFTWARE / SOUND CHIPS



ATTENTION



Game power must be OFF before removing or installing any software chips.
Turn OFF the power strip located inside the game.

Installing the Software Chip

1. You will notice a small dimple on one edge of the chip.

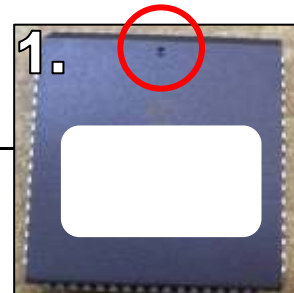

2. That dimple should line up with an arrow in the socket on the board.

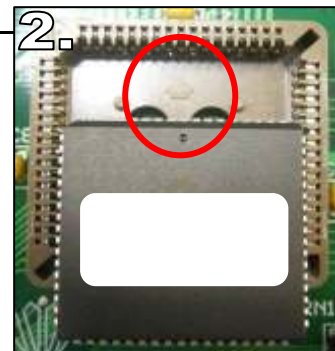

3. Line the legs of the chip with the slots in the socket and push the chip

NOTE: The legs on the chip should not be bent at all.



Installing the Sound Chip

1. You will notice a small notch on one edge of the chip.

2. That notch should line up with a notch in the socket on the board.

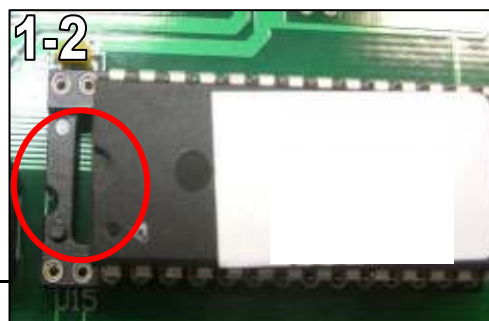

3. Line the legs of the chip with the slots in the socket and push the chip

NOTE: The legs on the chip should not be bent at all.



SOFTWARE UPGRADE LOG

If you replace the software in your game it is recommended that you note the changes made. Below is a chart you can use to track software upgrades.

DATE	MAIN or SOUND CHIP	VERSION INSTALLED	REASON FOR CHANGE	INTL.
	M / S			
	M / S			
	M / S			
	M / S			
	M / S			
	M / S			
	M / S			
	M / S			
	M / S			
	M / S			
	M / S			
	M / S			
	M / S			
	M / S			
	M / S			
	M / S			

POWER SUPPLY DIAGNOSTICS

Use the following procedure to check the Power Supply for Gen 5 games.

Start by removing the backdoor to gain access to the Power Supply. It is mounted directly to the left of the PCB.

Look for the small green LED light on the Power Supply circuit board. If the light is out there is a short somewhere. If the light dims, there is an overload in one of the circuits such as a bad motor.

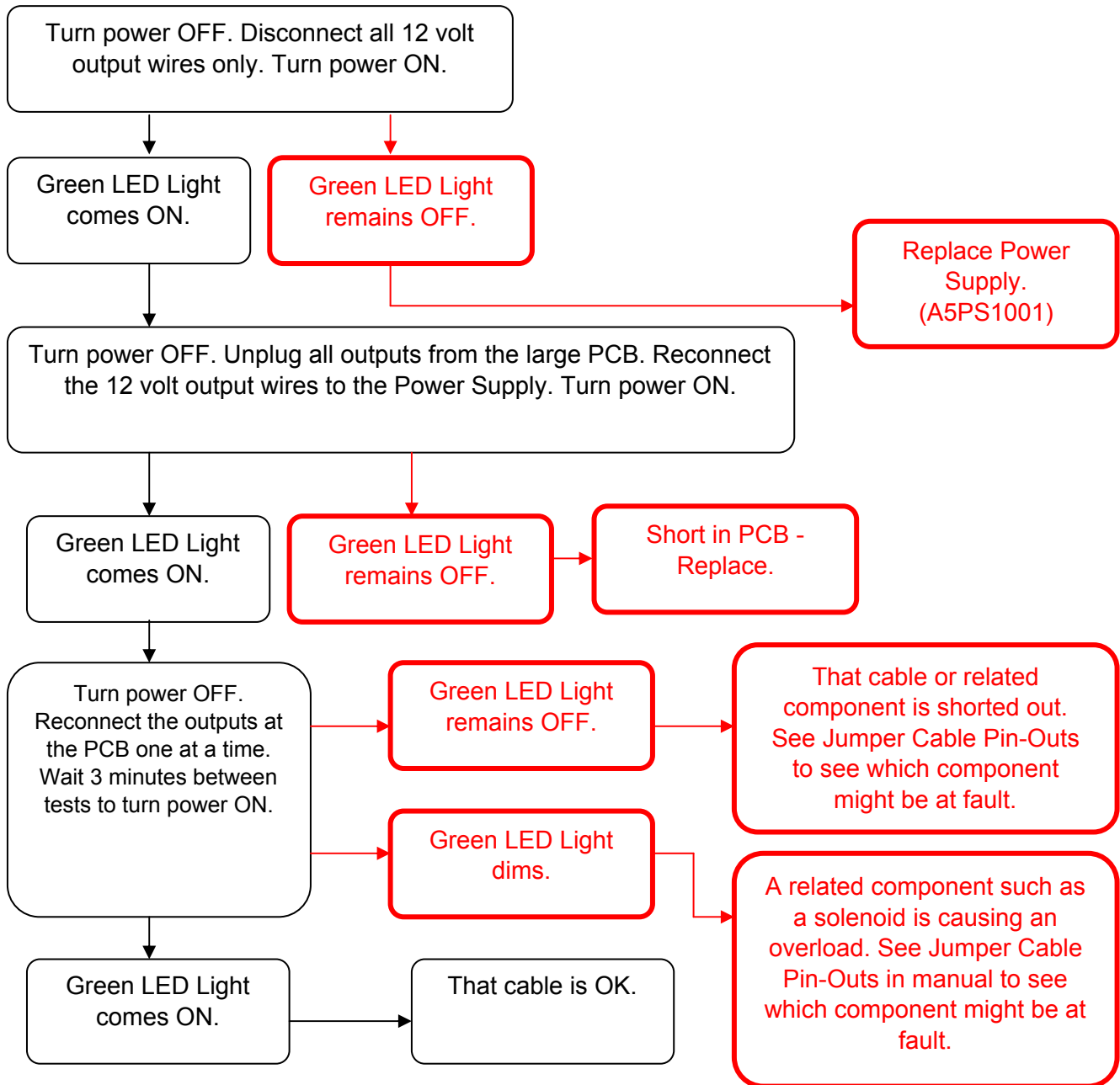
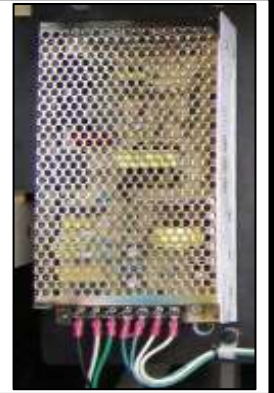

MAINTENANCE CHECKLIST

Use the following chart as a guide only.
Actual maintenance will depend on usage and environmental conditions at your location.
Keep a log of all inspections, even if no problems were found.

DANGER

DO NOT perform repairs or maintenance on this game with the power ON. Unplug the unit from the wall outlet or shut off the power at the power strip located inside the game cabinet.

WARNING

Use of flammable substances can cause severe burns or serious injury. Always use NON-FLAMMABLE solvents for cleaning. DO NOT use gasoline, kerosene, or thinners.

ATTENTION

DO NOT use any cleaning solvents on the games graphics. Use only a mild soap solution and a clean lint free cloth.

Inspect the game for damage. Repair as needed.	DAILY
Check all game lighting. Repair or replace lamps as needed.	DAILY
Fill ticket trays.	DAILY
Empty coin box.	DAILY
Test game to ensure proper operation.	WEEKLY
Clean outside surfaces with warm soapy water only. Do Not use solvents on decals or acrylic surfaces.	WEEKLY
Clean front glass with glass cleaner and a clean lint free cloth.	WEEKLY
Blow paper dust from the ticket dispenser outside the game. Clean more often if conditions dictate.	MONTHLY

TECHNICAL SUPPORT



Excellent customer service is very important to Bay Tek Games! We know that keeping your games in great operating condition is important to your business. When you need us, we are here to help. You can call us for free technical assistance, and you can count on us to have parts on-hand to support your game. When you do need us, it's important that you know what to expect. We offer options that fit your needs.

Electronics / Circuit Boards:

• **Repair & Return** – If you have Circuit Board issues with your Bay Tek game, you can send the board to us and we'll repair it right away. Most items sent to us are repaired and returned to you within two days. This option is your best value as we offer this fast turn-around service at the most reasonable price.

• **Advance Replacement** – If you have Circuit Board issues with your Bay Tek game, but you don't have time to send in your board in for repair, give us a call and ask for an Advance Replacement. We'll send you a replacement board that same day (pending availability). When you get your new board, just repackage the defective board in the same box and send it back to us. We make it easy by including a UPS Return-Shipping label for you to put on the box.

This is your best option when you need to get your game up and running as quickly as possible!

• **Spare Parts** – Take matters into your own hands and purchase new spare Circuit Boards for your Bay Tek games. Many of our games share the same main-board electronics. This means you can buy one set of spare electronics to support many of your Bay Tek games. Spare boards allow you to get your game up and running the quickest and provide you a valuable troubleshooting option. Call our technicians to get recommendations for what you should keep on hand for spare parts!

Technical Support:

“You” are the best tool for troubleshooting! Your abilities to understand the game and your skills to repair the game are invaluable to us! If you need help, you know you can call us. It's not easy to diagnose a game remotely by phone, but our technicians do a great job. They'll need your help to perform some troubleshooting steps and convey to them exactly what's happening with your game.

Returns & Credits:

Sometimes the issue isn't what it seemed to be. If you chose the Advance Replacement option and now need to return that circuit board, just give us a call to get Return Authorization. You will be credited for the cost of the board and charged only the bench fee for our processing and retesting that board. If you choose the Repair and Return option, we'll test your board before we begin. If no problems are found, you will only be charged the bench fee.

Note: Bench fees apply regardless of whether the repair was your choice or a recommendation from a Bay Tek Games technician.

It's a small price to pay for troubleshooting the issues with your game.

[You can count on our Technical Support Team for service and support!](#)

WARRANTY OPTIONS

Bay Tek Games warrants to the original purchaser that the game will be free of defects in workmanship and materials for a period of 6 months from the date of installation.

Register your new game for an extra 3 months on your warranty.

See page 1 for registration information.

Bay Tek Games will, without charge, repair or replace at it's option defective product or component parts upon notification to the parts/service department.

Warranty replacement part(s) will be shipped immediately via ground service, along with a **Return Material Authorization** (RMA) number for the return of defective part(s). Defective part(s) must be shipped back to Bay Tek Games unless otherwise instructed.

This warranty does not apply in the event of any misuse or abuse to the product, or as a result of any unauthorized repairs or alterations. The warranty does not apply if the serial number decal is altered, defaced, or removed from it's original position.

Should you need your game serviced, determine the serial number from the decal on the back of the game cabinet or main board, and call **920.822.3951** and press **1** when prompted or e-mail to: service@baytekgames.com

NON-WARRANTY PARTS

Should your game need servicing, determine the serial number from the decal on the back of the game cabinet or the main board, and call **920.822.3951** or e-mail to: service@baytekgames.com

An estimate of the repair charges will be quoted to you for approval.
You may now proceed in one of two ways.

Option 1:

Request immediate shipment of advance replacement part(s).

You will receive the part(s) with
a **RMA** for the return of the faulty part(s).

You must return the faulty part(s) in 14 days to avoid additional charges.

Option 2:

Send in the faulty part(s) for repair or replacement.

Please include the following information

NAME

ADDRESS

PHONE #

SERIAL #

PURCHASE ORDER NUMBER or

SIGNED AUTHORIZATION to perform service.

Repair and returned part(s) will be shipped back using the same method in which they were received.

Repairs are warranted 30 days from the date installed into service.

ELECTRICAL DRAWINGS

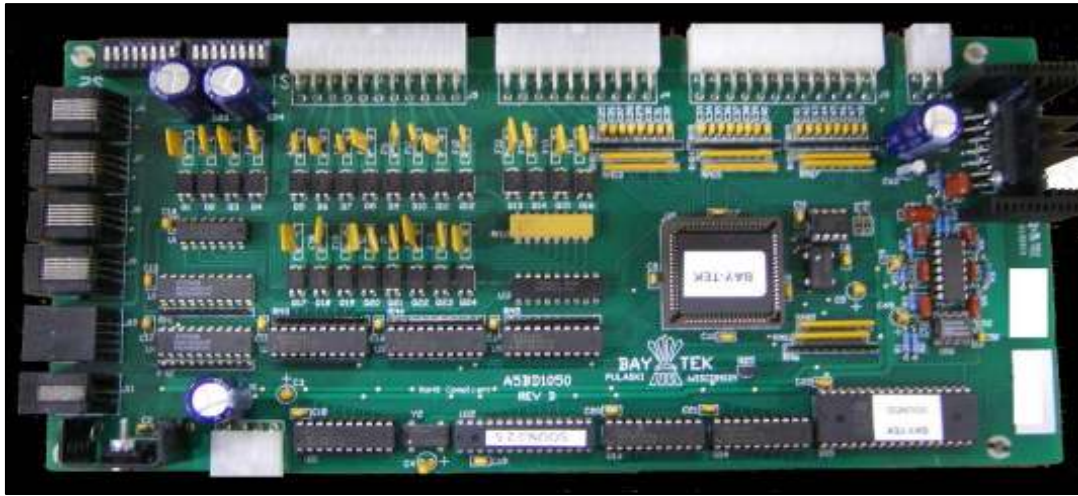

PCB DRAWING

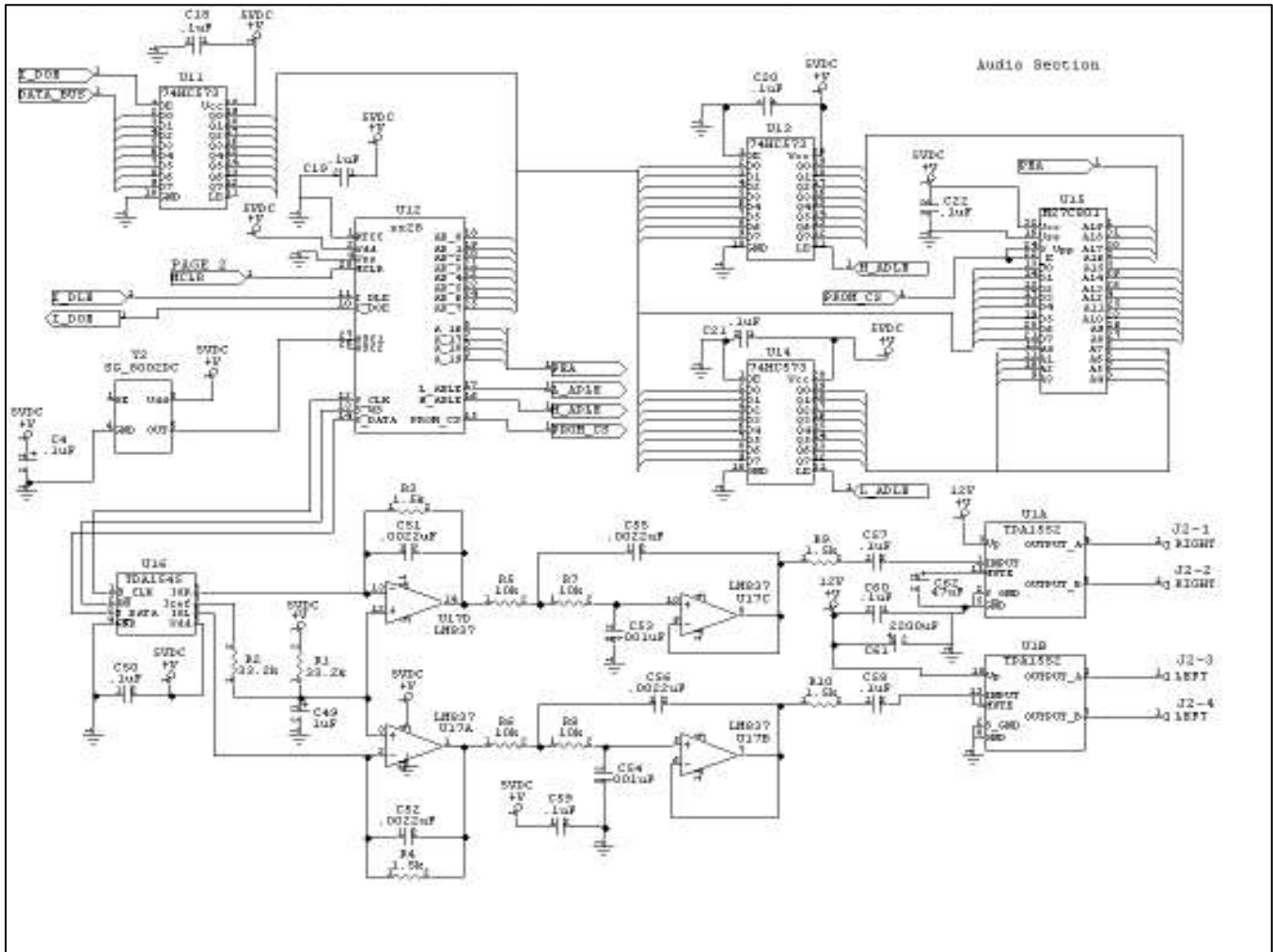

Communications - Serial EEprom

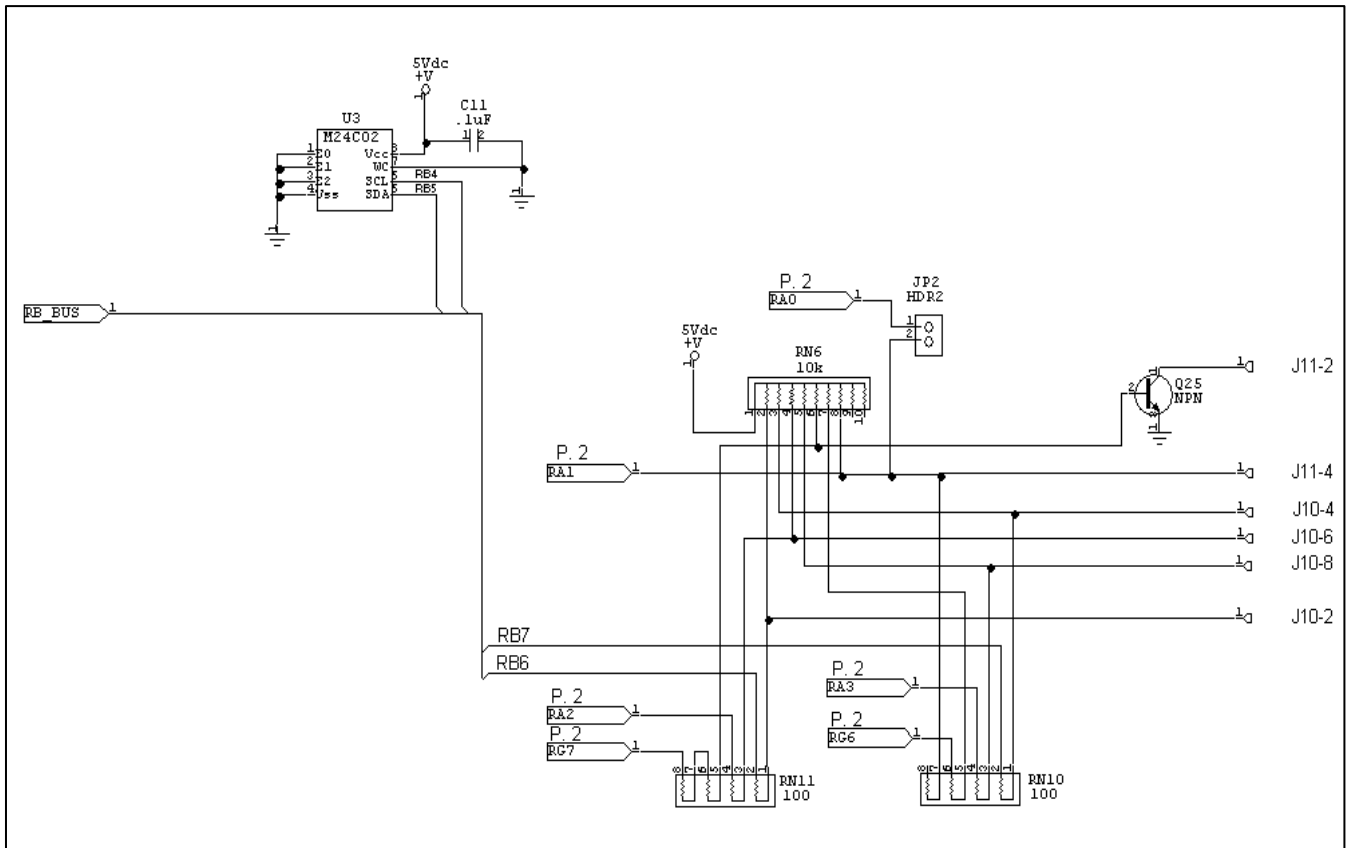

Input Section A - Con. Switches

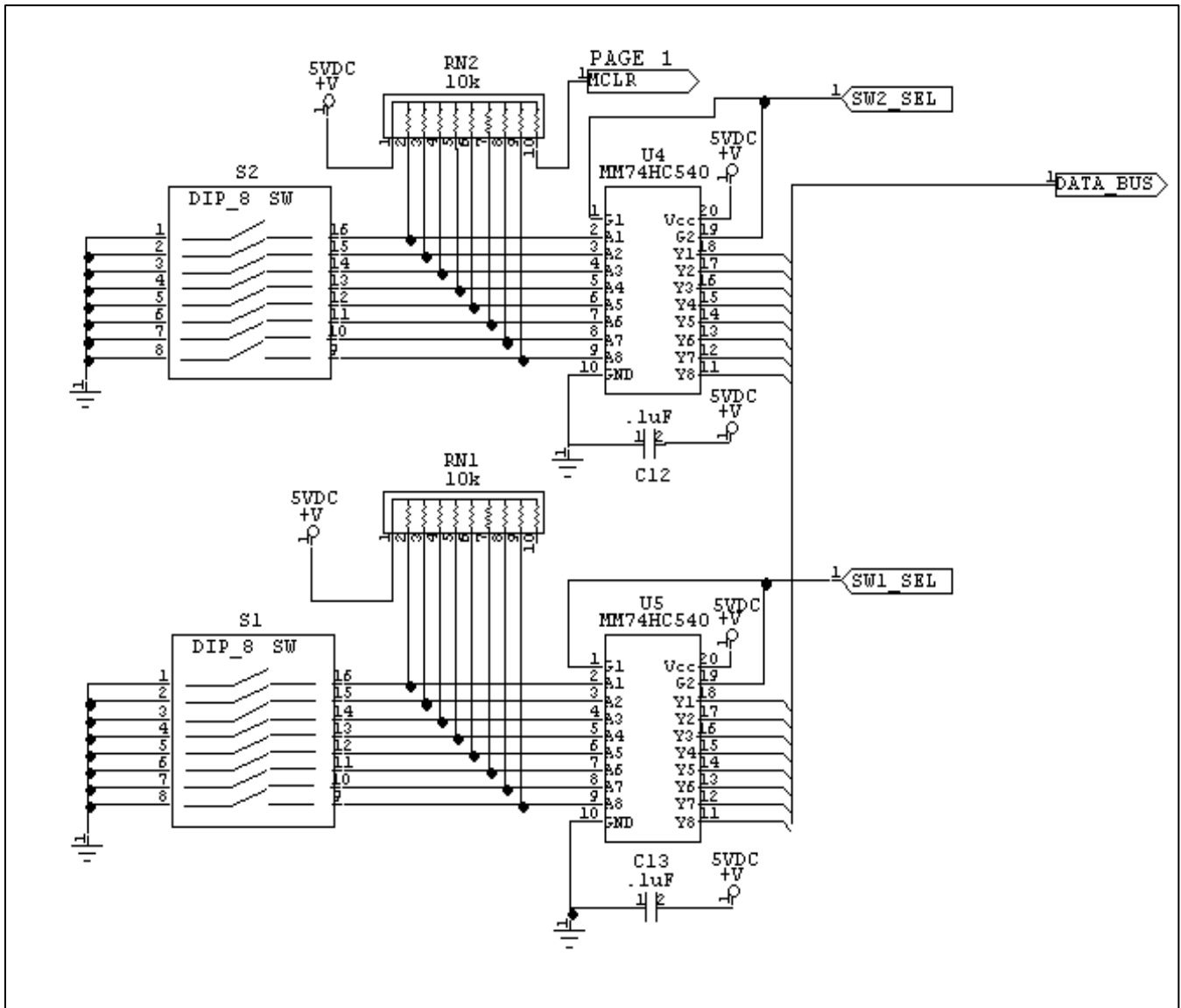

Input Section B - Inputs RE, RC

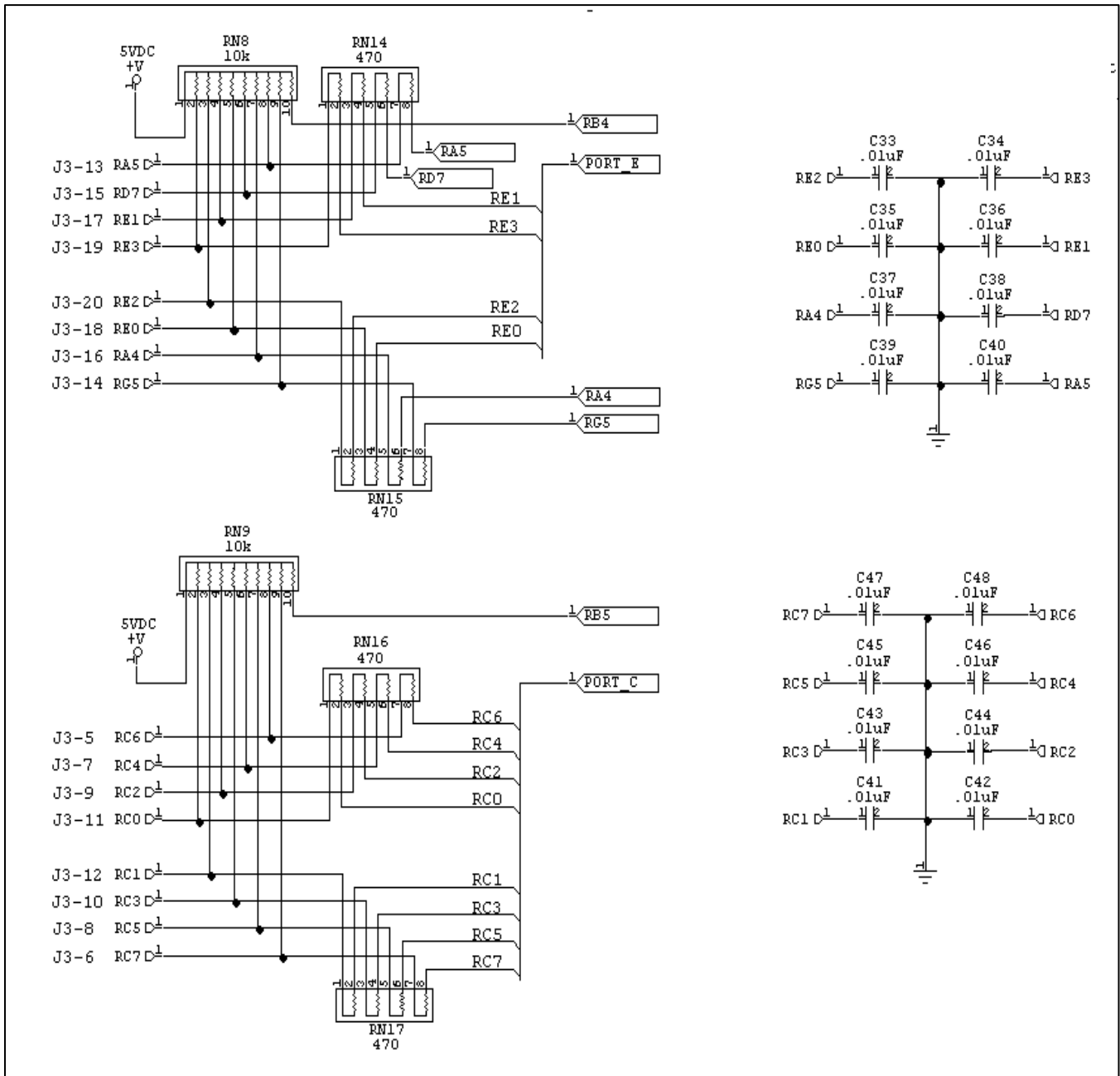

Output Section - Chase lights Q13-Q16

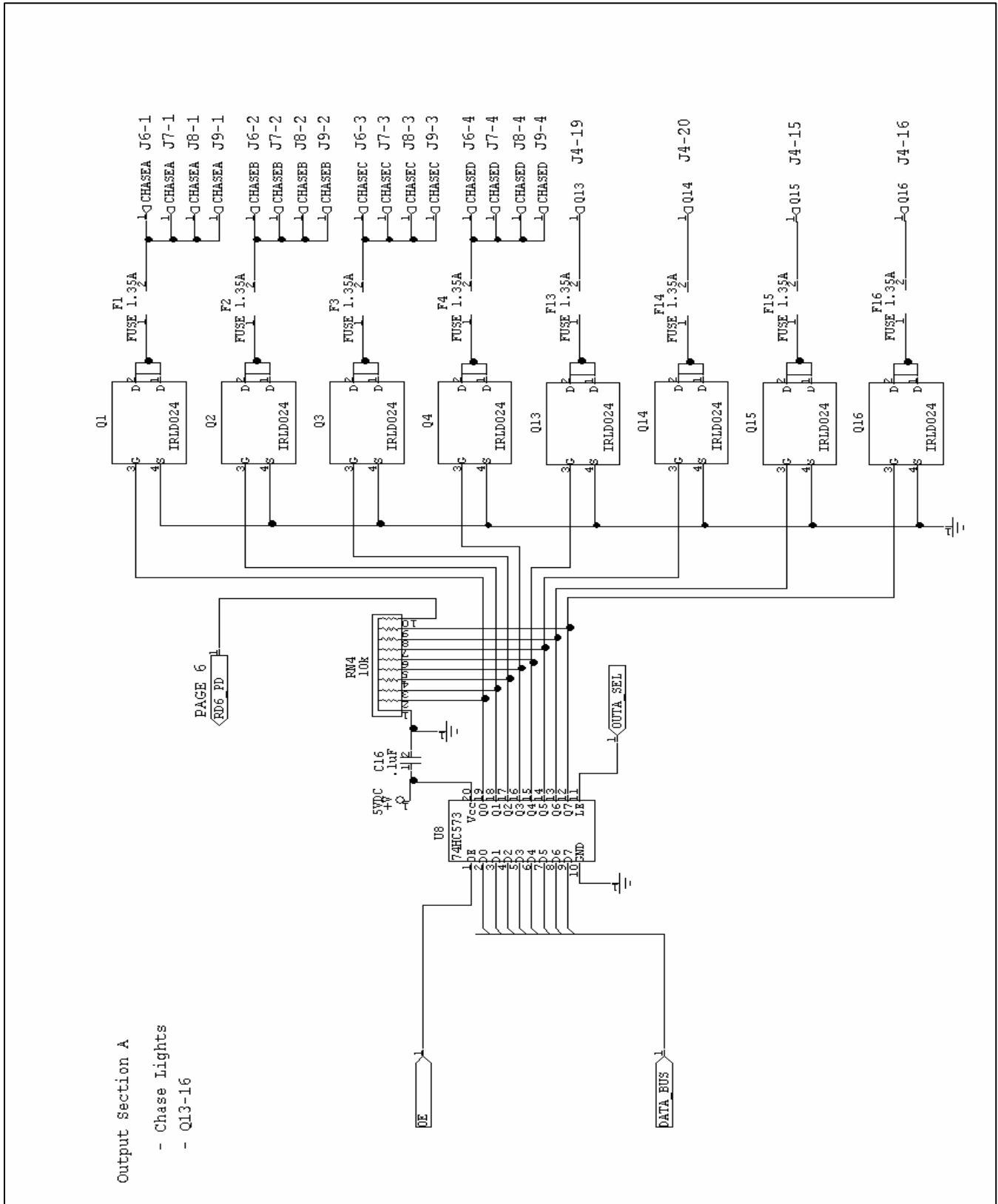

Output Section B Q17-Q24

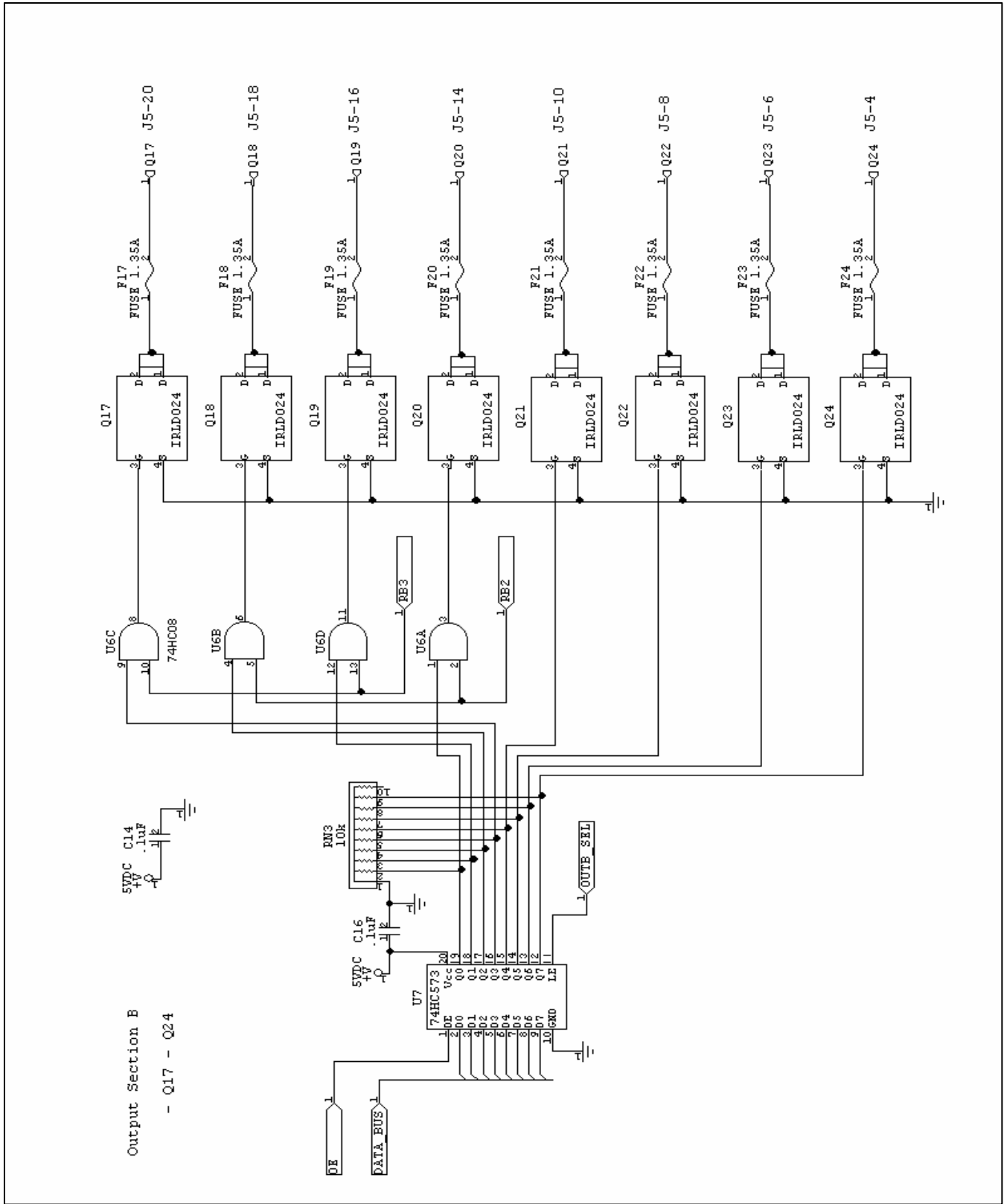

Output Section C Q5-Q12

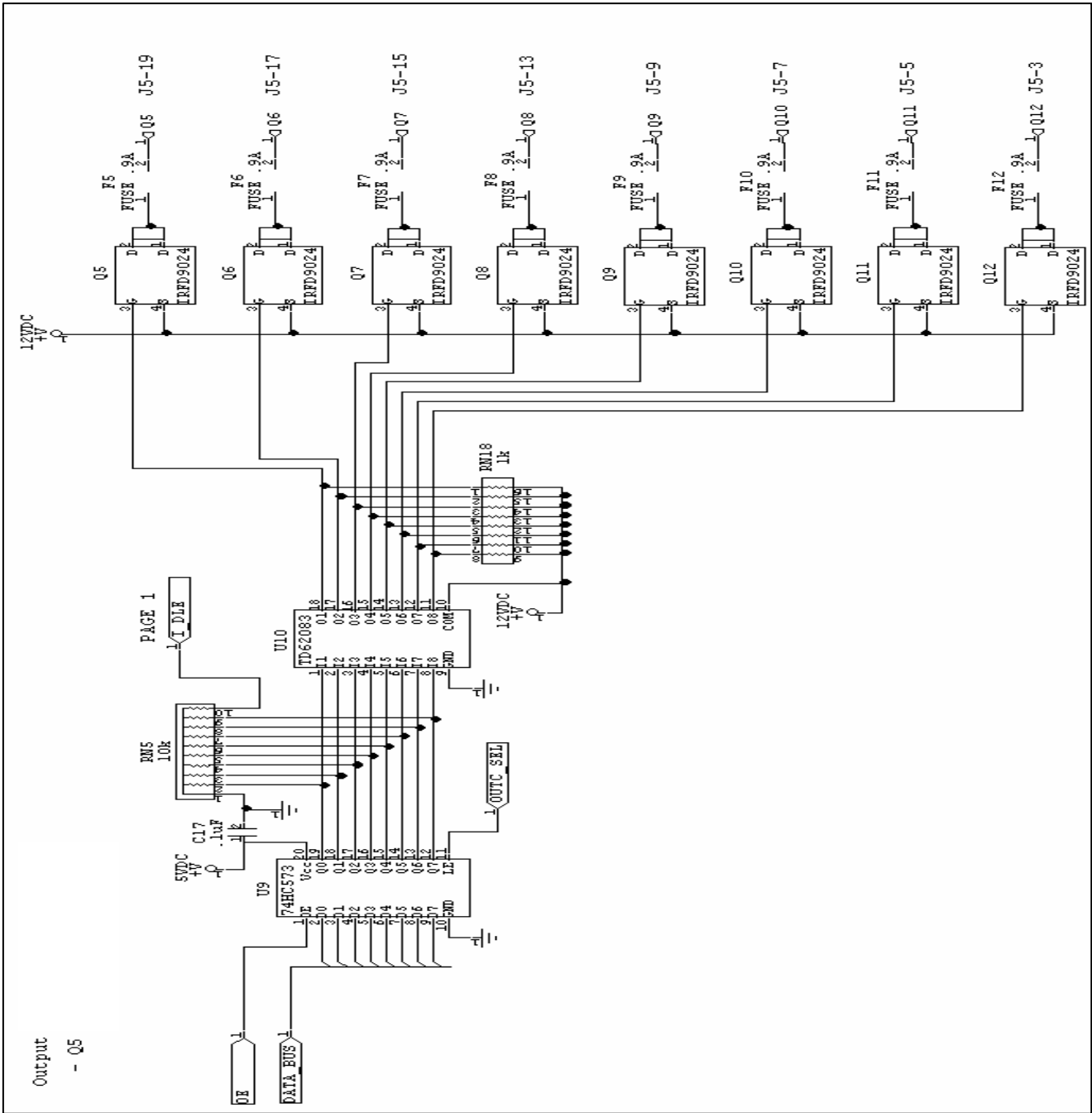

Power Section

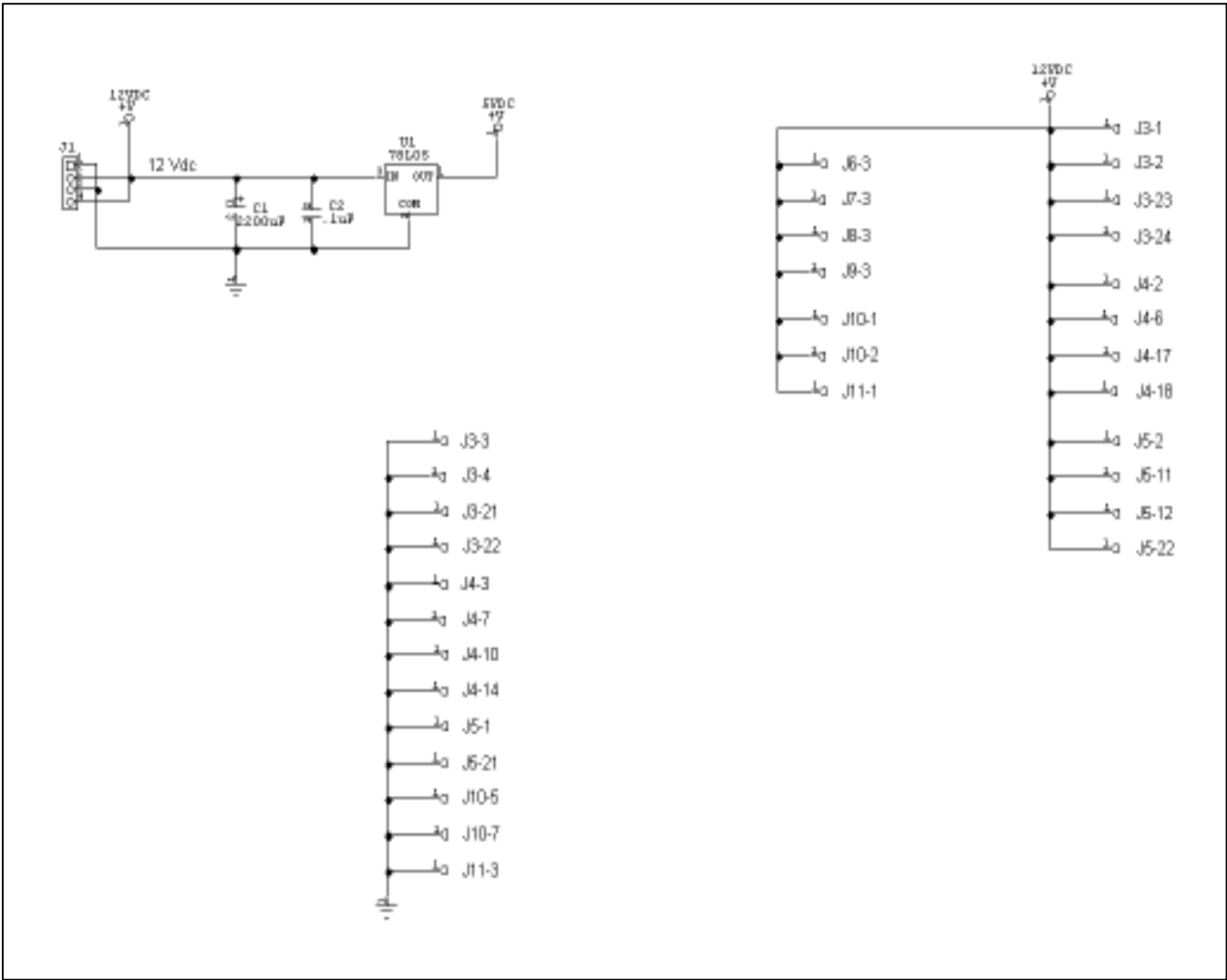

Processor Section - Input RD

