



**MONOPOLY TFT
TWIN PUSHER
93.738.330**

Table of Contents

1. Copyright

2. Warranty

3. Safety Instructions.

- 3.1 Product Safety
- 3.2 Electrical Safety General
- 3.3 Chemical Safety
- 3.4 Fire Safety
- 3.5 Disposal of Hazardous Components

4. Installation Instructions & Daily Checks

- 4.1 General
- 4.2 Physical check
- 4.3 Internal Electrical connections
- 4.4 Electrical Supply
- 4.5 Power Supply Unit
- 4.6 Microprocessor Connections & Functions
- 4.7 Dimensions & Weight
- 4.8 Abbreviations
- 4.9 Daily Checks

5. Machine description & Coin prime.

- 5.1 Product Overview
- 5.2 Coin floating

Table of Contents

6. Operator Adjustments.

- 6.1 Ticket Payout
- 6.2 Tilt
- 6.3 Set Up Menu
- 6.4 Adjustment of Lose Hole size
- 6.5 Playfield Riser
- 6.6 Ticket Dispensers
- 6.7 Universal Hoppers
- 6.8 Lamp Matrix
- 6.9 Switch Matrix
- 6.10 VORTEX Layout
- 6.11 MPU Layout / Plug Locations

7. Fault finding guide.

- 7.1 Machine does not work
- 7.2 Pusher motor not running
- 7.3 The tilt does not work
- 7.4 The tilt will not stop
- 7.5 No ticket layout
- 7.6 The halogen lamps do not work

8. Machine BOM (including Illustrations)

COPYRIGHT

The Jumping Bean Company / Cromptons / Bell-Fruit Games Ltd. / Mazooma Games Ltd. possess exclusive copyright in the SOFTWARE & HARDWARE contained within this machine. Purchasers have no authority to reproduce any part of Jumping Bean Company / Cromptons. / Bell-Fruit Games Ltd. / Mazooma Games Ltd. software, including copying of EPROMS, unless permission is granted in writing.

The Jumping Bean Company / Cromptons. / Bell-Fruit Games Ltd. / Mazooma Games Ltd. also retains various intellectual property rights in the form of LETTERS PATENT, REGISTERED DESIGNS and TRADE MARKS (both in force and pending) applicable to this machine. The purchaser's right to use these is restricted to operation of the machine in its original form, or in modified form ONLY IF such modifications have been carried out under

The Jumping Bean Company / Cromptons. / Bell-Fruit Games Ltd. / Mazooma Games Ltd. express written licence to do so. Particular note should be taken of any patent numbers identified within the artwork design or game manual of this machine.

Copyright also exists in the ARTWORK DESIGNS for this machine. No part of this artwork may be reproduced in any way without written authority.

The THREE BELLS DEVICE & SCORPION 5™ are REGISTERED TRADEMARKS of Bell-Fruit Games Ltd.

PERSONS WISHING TO MAKE USE OF ANY OF THE INTELLECTUAL PROPERTY ABOVE SHOULD CONTACT MAZOOMA GAMES LTD IN THE FIRST INSTANCE

Every effort has been made to ensure that the information contained within this manual is accurate. Mazooma Games Ltd reserves the right to make alterations without prior notice.

WARRANTY

Seller warrants that its microprocessor unit and parts thereon, are and shall remain free from defects in material and workmanship under normal use and service for a period of six months from date of purchase.

Seller warrants that other products or parts thereof shall remain free from defects in material and workmanship under normal use and service for a period of 90 (ninety) days from date of purchase.

If the products described in this manual fail to conform to this warranty, seller's sole liability shall be at it's option to repair, replace or credit buyer's account for such products which are returned to seller during said warranty period, provided:

- a) Seller is promptly notified in writing upon discovery by Buyer that the said products are defective.
- b) Such products are returned prepaid to seller's plant.
- c) Seller's examination of said products discloses to seller's satisfaction that such alleged defects existed and were not caused by accident, neglect, alteration, improper repair, installation or improper testing.
- d) Only seller's recommended or approved electronic components are used as service replacements.

In no event shall seller be liable for loss of profits, loss of use, incidental or consequential damages.

Except for any express Warranty set forth in a written Contract between Seller and Buyer which Contract is expressed to supersede the terms of this warranty, all implied warranties and conditions as to quality or fitness for any particular purpose are hereby expressly excluded.

No employee of the Seller has any authority to waive or amend the terms of this warranty that shall be deemed accepted by the Buyer on acceptance of the products referred to above.

ALL WARRANTY CLAIMS FOR THIS MACHINE WILL BE DEALT WITH BY THE BELL-FRUIT GAMES AFTERSALES DEPARTMENT.

Tel: 0115 9706707

E-MAIL: technical@bellfruitgames.co.uk

SAFETY INSTRUCTIONS

WARNING

- Maintenance and repair operations should only be carried out by suitably skilled and instructed persons.
- To maintain the safety of the machine, use only parts approved by The Jumping Bean Company / Cromptons Leisure International Ltd. / Bell-Fruit Games Ltd. and Mazooma Games Ltd. The use of other parts or non-approved modifications to the machine could be hazardous.

CAUTION

- Many electrical connectors are keyed to fit only one way. Note orientation before removal.
- When touching any PCBA (Printed Circuit Board Assembly) or their component parts, take full anti-static precautions.

3.1 **Electrical Safety General**

All machines are tested for electrical safety prior to being despatched. The tests are for Earth Bond and Insulation. It is recommended that these tests are repeated annually or whenever safety critical parts and connections are replaced.

- Disconnect the mains power supply before attempting to dismantle or repair any part of the machine.
- Always observe high voltage and hazard warning labels.
- Be aware of capacitors fitted to the machine PSU. Use only the specified fuses stated in the machine and in this manual.
- Always refit safety covers and safety earth wires connected to metal parts.
- Earth/Insulation specifications for BFG machines are: -
 - Insulation > 2 Megohms @ 500V dc.
 - Earth Bond < 0.25 ohms @ 25 amps.

SAFETY INSTRUCTIONS

3.2 **Product Safety**

An equally wide range of manufacturers supplies the wide range of components used in the machine. It is therefore impracticable for this document to provide comprehensive safety data for each product used.

Manufacturers data sheets can be supplied upon request.

All the items contained within the machine are used within their specification limits and in accordance with sound engineering practice.

3.3 **Chemical Safety**

Attention is drawn to the possible effect of accidental damage to components where they contain chemicals that may be hazardous. Components that fall into this category are: -

Electrolytic Capacitors

Nickel Cadmium Batteries

Semi-Conductors containing Beryllium Oxide and Gallium Arsenide

Opto-Electronic devices using Gallium Phosphide

As the chemicals are corrosive or flammable, particular care must be exercised in case of spillage. Any part of the body that accidentally comes into contact with these chemicals must be thoroughly washed in cold running water, particularly if the eyes are affected. Medical advice should be sought.

SAFETY INSTRUCTIONS

3.4 Fire Safety

Outer casings of the majority of the components used are made of heat resistant material. Excessive electrical overload conditions may generate sufficient heat to ignite chemical substances within the components themselves or adjacent components, harnesses etc.

NOTE:

It is imperative that only identical value components are used as replacements for the original equipment supplied and that correct polarity of assembly is observed when applicable.

Materials that fall into the Fire Hazard category are: -

- **Chipboard and MDF** - releases Formaldehyde vapours when ignited, causes discomfort to the eyes and mucous membranes.
- **Plastic Laminates** - plastic and rubber mouldings, wire insulation etc., release noxious fumes, which if inhaled may cause irritation depending on the sensitivity of the individual.
- **Glass** - extreme heat will cause the glass to crack thereby causing injury.
- **Electrolytic Capacitors and Batteries** - may explode if subjected to fire.
- **Foamex** – flammable.

3.5 Disposal of Hazardous Components

As a general rule, electronic components should not be incinerated due to the possible danger of noxious fumes being released, or components exploding due to a build up of internal pressures created by expanding gases.

INSTALLATION INSTRUCTIONS & DAILY CHECKS

4.1 General

It is the policy to ensure that all products are designed, manufactured, tested and released to conform to statutory safety requirements. In support of this policy the information contained within this manual is intended as a guide to the safe installation, reliable working and efficient operation of the machine supplied.

Therefore prior to installation or when servicing, reference to the service manual and all **WARNING LABELS** provided is strongly recommended. Failure to observe any information may result in a safety hazard.

CAUTION: Under no circumstances should any major form of installation, repair, adjustment or maintenance be attempted by any other than qualified personnel.

4.2 Physical Check

Ensure that the machine is positioned on a level stable surface and remove all of the transit packaging. Open all doors and check that all parts are secured, electrical connectors are correctly mated and that no components or assemblies have been damaged in transit.

4.3 Internal Electrical Connectors

The introduction of insulation displacement connectors (IDC) and the use of lighter cables emphasise the need for care when removing and replacing connectors.

When removing connections, pull on the connector and not the wires; when replacing connections ensure that (i) the harness housing is being connected to the correct wafer (ii) the housing is the correctly oriented (Observe positions of polarising pins).

INSTALLATION INSTRUCTIONS & DAILY CHECKS

4.4 Electrical Supply **WARNING: This Apparatus must be EARTHED.**

Connect the machine to the mains supply (110/120Vac) using an approved plug. The mains lead is factory fitted to the machine.

IMPORTANT: The wires in the mains lead are coloured in accordance with the following code.

GREEN	:	EARTH
WHITE	:	NEUTRAL
BLACK	:	LIVE

As the colours of the wires in the mains lead may not correspond with the coloured markings identifying the terminals in your plug, proceed as follows.

1. **EARTH:** The wire coloured GREEN must be connected to the terminal marked 'E' or by the safety earth symbol or coloured GREEN.
2. **NEUTRAL:** The wire coloured WHITE must be connected to the terminal marked 'N'.
3. **LIVE:** The wire coloured BLACK must be connected to the terminal marked 'L'.

INSTALLATION INSTRUCTIONS & DAILY CHECKS

4.5 Power Supply Unit

The Scorpion 5 power supply consists of a mains switched mode power supply providing steady D.C voltages from a mains input supply.

The mains input is fed via an IEC plug, mains filter and double pole switch and is protected by a 5 Amp anti surge fuse.

Supply Outputs

The Power Supply outputs are:-

- a) 44vdc This supply is used for the lamps matrix.
- b) 24vdc This supply is used for the hoppers.
- c) 13vdc This supplies the MPU, Coin Acceptor and Reel Mechanism.
- d) 5vdc This is the I.C. supply on the MPU.
- e) -12vdc This is the supply for E.D.C units

Power Supply Removal

To remove the power unit from the machine disconnect the Power Supply harness and the earth ring tags from the stud.

CAUTION: Extra care should be taken when finally lifting the power supply from the machine.

When replacing the unit ensure that all the earth ring tags are securely fastened to the stud (identified by means of an earth symbol and that the plug is reconnected

INSTALLATION INSTRUCTIONS & DAILY CHECKS

4.6 Microprocessor Connections & Functions

The microprocessor unit MPU (Designated Scorpion 5) is mounted horizontally on the back panel of the machine. Harnesses to the MPU are generally direct from each assembly and colour coded. Harnesses are terminated by polarised IDC connectors of 0.156 and 0.1"pitch.

Additional Functions

Reset LED A red LED indicates the state of the system reset. It will illuminate at power up and extinguish after 2 seconds showing that the system reset has taken place. A red button adjacent to the Dil switches resets the MPU (normally used when bench testing).

Game Card The game card has both game and sound proms and should be fitted to the 96 way connector Plug Z on the Microprocessor.

LED Indicators 7 red LED's are provided to indicate the presence of the supplies to the MPU.

DIL Switches There are two banks of DIL switches on the MPU board, set horizontally, numbered 1 to 8 from bottom to top, totaling 16 (see diagram). These must be set in the "OFF" position before switching on the machine.

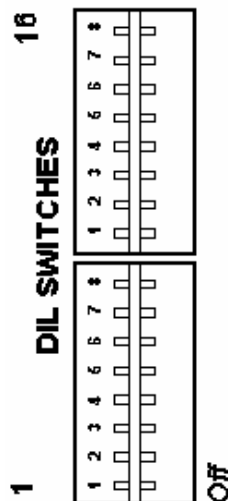

INSTALLATION INSTRUCTIONS & DAILY CHECKS

Microprocessor Connections

<u>PLUG - FUNCTION</u>	<u>CONNECTOR</u> <u>SIZE</u>	<u>POLARISED</u> <u>PIN</u>
A. - POWER IN.	20way Mini-Fit Jr.	N/A
B. - CAB SWITCHES.	10way Dual row header.	Pin 7.
C. - REEL INPUTS.	10way Dual row header.	Pin 3.
D. - REEL OUTPUTS.	40way Dual row header.	Pin 37
E. - GAME SWITCHES.	20way Dual row header.	Pin 6.
F. - L.E.D.s.	34way Dual row header.	Pin 18
G. - S&P Key.	9way 'D' Type Socket.	N/A
H. - % Key.	9way 'D' Type Plug.	N/A
J. - LAMPS.	34way Dual row header.	Pin 17.
K. - REEL LAMPS.	16way Dual row header.	Pin 9.
L. - GENERAL I/O.	16way Dual row header.	Pin 5.
M. - AUDIO OUTPUT.	10way Dual row header.	Pin 8.
N. - ALPHA 1 & 2.	11way 0.1" KK Connector.	Pin 3.
P. - SEC METER.	7way 0.1" KK Connector.	Pin 5.
Q. - CCTalk I/F.	10way Dual row header.	Pin 6.
R. - RS232 PORT 2.	8way 0.1" KK Connector.	Pin 6.
S. - RS232 PORT 1.	25way 'D' Type Plug.	N/A
T. - HI2 I/F.	10way Dual row header.	Pin 9.
V. - I2C I/F.	6way 0.1" KK Connector.	Pin 3.
Z. - GAME CARD.	96 way DIN a+b+c Edge Connector.	N/A

INSTALLATION INSTRUCTIONS & DAILY CHECKS

PLUG A. - POWER IN.

20way Mini-Fit Jr. Molex HSG 39-01-2200. Crimp 39-00-0038

PIN No.	WIRE TYPE & COLOUR	DESCRIPTION	PIN No.	WIRE TYPE & COLOUR	DESCRIPTION
01	24/0.2 Type 2 GRN	: +13.5V	11	n/a	: GND
02	24/0.2 Type 2 GRN	: +13.5V	12	24/0.2 Type 2 BLK	: GND
03	24/0.2 Type 2 VLT	: +44V	13	24/0.2 Type 2 BLK	: GND
04	24/0.2 Type 2 VLT	: +44V	14	24/0.2 Type 2 BLK	: GND
05	24/0.2 Type 2 YLW	: +5V	15	24/0.2 Type 2 BLK	: GND
06	n/a	: +5V	16	24/0.2 Type 2 BLK	: GND
07	24/0.2 Type 2 RED	: +13.5V	17	24/0.2 Type 2 BLK	: GND
08	24/0.2 Type 2 RED	: +13.5V	18	24/0.2 Type 2 BLK	: GND
09	24/0.2 Type 2 BLU	: -12V	19	24/0.2 Type 2 BLK	: GND
10	24/0.2 Type 2 PNK	: +24V	20	n/a	: GND

PLUG C. - REEL INPUTS.

10way Dual row header Polarised Pin 3. Molex HSG 90142-0010. Crimp 90119-0109.

PIN No.	WIRE TYPE & COLOUR	DESCRIPTION	PIN No.	WIRE TYPE & COLOUR	DESCRIPTION
01	n/a		06	7/0.2 Type 2 BLU/YLW	: Sacoa Out Pulse Player 2
02	n/a		07	n/a	
03	POLARISING KEY.		08	7/0.2 Type 2 YLW	: Ticket Notch Sensor Player 1
04	7/0.2 Type 2 YLW/BLK	: Ticket Notch Sensor Player 2	09	n/a	
05	n/a		10	7/0.2 Type 2 BLU	: Sacoa Out Pulse Player 1

INSTALLATION INSTRUCTIONS & DAILY CHECKS

PLUG D. - REEL OUTPUTS.

40way Dual row header Polarised Pin 37. Molex HSG 90142-0040. Crimp 90119-0109.

PIN No.	WIRE TYPE & COLOUR	DESCRIPTION	PIN No.	WIRE TYPE & COLOUR	DESCRIPTION
01	n/a	:	21	7/0.2 Type 2 BLU/WHT	: 2 Player Cash In Meter
02	7/0.2 Type 2 WHT	: +13.5V Sacoa / Ticket 2 Player	22	7/0.2 Type 2 BLU/RED	: 2 Play Cash Out Meter
03	n/a	:	23	7/0.2 Type 2 BLU/GRN	: 2 Player Cash Box
04	n/a	:	24	7/0.2 Type 2 BLU/BLK	: 2 Player Ticket Out
05	n/a	:	25	n/a	: 13v Relay Drive 1&2PI
06	n/a	:	26	n/a	:
07	7/0.2 Type 2 RED	: +13.5V Meters	27	7/0.2 Type 2 GRN/RED	: Flap coil relay 1Player
08	n/a	:	28	7/0.2 Type 2 GRN/BLU	: Flap coil relay 2Player
09	7/0.2 Type 2 WHT/BLK	: 1 Player Ticket Drive	29	n/a	:
10	7/0.2 Type 2 PNK/RED	: 1 Player Sacoa Inhibit	30	n/a	:
11	7/0.2 Type 2 WHT	: 2 Player Ticket Drive	31	n/a	:
12	7/0.2 Type 2 PNK	: 2 Player Sacoa Inhibit	32	n/a	:
13	n/a	:	33	n/a	:
14	n/a	:	34	n/a	:
15	7/0.2 Type 2 BLU/WHT	: 1 Player Cash In Meter	35	n/a	:
16	7/0.2 Type 2 BLU/RED	: 1 Player Cash Out Meter	36	n/a	:
17	7/0.2 Type 2 BLU/GRN	: 1 Player Cash Box	37	POLARISING KEY.	: n/c
18	7/0.2 Type 2 BLU/BLK	: 1 Player Ticket Out	38	7/0.2 Type 2 BLK	: 0V Ticket
19	7/0.2 Type 2 RED	: +13.5V Sacoa / Ticket 1Player	39	n/a	:
20	n/a	:	40	7/0.2 Type 2 BLU	: 0V Sacoa

PLUG E. - GAME SWITCHES.

20way Dual row header Polarised Pin 6. Molex HSG 90142-0020. Crimp 90119-0109.

PIN No.	WIRE TYPE & COLOUR	DESCRIPTION	PIN No.	WIRE TYPE & COLOUR	DESCRIPTION
01	7/0.2 Type 2 ORG/BLK	: SWD_0	11	7/0.2 Type 2 BLK/GRN	: LDS_04
02	7/0.2 Type 2 ORG/BRN	: SWD_1	12	7/0.2 Type 2 BLK/BLU	: LDS_05
03	7/0.2 Type 2 ORG/RED	: SWD_2	13	7/0.2 Type 2 BLK/VLT	: LDS_06
04	7/0.2 Type 2 ORG/YLW	: SWD_3	14	7/0.2 Type 2 BLK/GRY	: LDS_07
05	7/0.2 Type 2 ORG/GRN	: SWD_4	15	7/0.2 Type 2 BLK/WHT	: LDS_08
06	POLARISING KEY.	: n/c	16	7/0.2 Type 2 BLK/PNK	: LDS_09
07	7/0.2 Type 2 BLK/BRN	: LDS_00	17	7/0.2 Type 2 BLK/PNK + BRN	: LDS_10
08	7/0.2 Type 2 BLK/RED	: LDS_01	18	7/0.2 Type 2 BLK/PNK + RED	: LDS_11
09	7/0.2 Type 2 BLK/ORG	: LDS_02	19	7/0.2 Type 2 RED	: +13.5V
10	7/0.2 Type 2 BLK/YLW	: LDS_03	20	7/0.2 Type 2 BLK	: GND

INSTALLATION INSTRUCTIONS & DAILY CHECKS

PLUG M. - AUDIO OUTPUT.

10way Dual row header Polarised Pin 8. Molex HSG 90142-0010. Crimp 90119-0109.

PIN No.	WIRE TYPE & COLOUR	DESCRIPTION	PIN No.	WIRE TYPE & COLOUR	DESCRIPTION
01	7/0.2 Type 2 WHT	: AUD_OUT	06	n/a	:
02	7/0.2 Type 2 BLU	: GND_AUDIO	07	n/a	:
03	n/a	:	08	POLARISING KEY.	: n/c
04	n/a	:	09	n/a	:
05	n/a	:	10	n/a	:

PLUG N. - ALPHA 1 & 2.

11way 0.1" KK Connector Polarised Pin 3. Molex HSG 22-01-2115. Crimp 4809T.

PIN No.	WIRE TYPE & COLOUR	DESCRIPTION	PIN No.	WIRE TYPE & COLOUR	DESCRIPTION
01	7/0.2 5/CORE A COL.1	: +13.5V	07	7/0.2 5/CORE B COL.1	: +13.5V
02	7/0.2 5/CORE A COL.2	: ACLK1	08	7/0.2 5/CORE B COL.2	: ACLK2
03	POLARISING KEY.	: n/c	09	7/0.2 5/CORE B COL.3	: ADAT2
04	7/0.2 5/CORE A COL.3	: ADAT1	10	7/0.2 5/CORE B COL.4	: ARST2
05	7/0.2 5/CORE A COL.4	: ARST1	11	7/0.2 5/CORE B COL.5+SCN	: GND
06	7/0.2 5/CORE A COL.5+SCN	: GND			

PLUG Q. - CCTalk I/F.

10way Dual row header Polarised Pin 6. Molex HSG 90142-0010. Crimp 90119-0109.

PIN No.	WIRE TYPE & COLOUR	DESCRIPTION	PIN No.	WIRE TYPE & COLOUR	DESCRIPTION
01	7/0.2 Type 2 WHT	: CCTALK Hoppers	06	POLARISING KEY.	: n/c
02	n/a	:	07	n/a	:
03	n/a	:	08	n/a	:
04	7/0.2 Type 2 BLK	: 0v Hoppers/Ticket Dispense	09	n/a	:
05	n/a	:	10	7/0.2 Type 2 PNK	: +24V Hoppers

Colour Abbreviation key.

BLK	- Black	BRN	- Brown	RED	- Red	ORG	- Orange
YLW	- Yellow	GRN	- Green	BLU	- Blue	VLT	- Violet
GRY	- Grey	WHT	- white	PNK	- Pink	SLV	- Silver
GLD	- Gold	SCN	- Screen				

INSTALLATION INSTRUCTIONS & DAILY CHECKS

4.7	<u>Dimensions</u>	Height with Top Display	7' 6"
		Height without Top Display	4' 9"
		Depth	2' 7"
		Width	3' 5"
		Weight (inc TFT & Surround Assy)	450 lbs (approx)

4.7 Abbreviations:

- **Coin Entry** - one or more slots in the coin entry panel where player may insert coin of play.
- **Coin chute** - metal chute that guides the coin from coin entry slot to centre pin perspex.
- **Centre pin perspex** - large perspex panel fitted with scatter pins that guide the coin down onto the pusher pad.
- **Pusher pad** - the moving pad assembly located at the rear of the playfield.
- **Playfield** - flat bed holding the coins to be pushed into the win chute.
- **Win chute** - large metal form located under front edge of playfield to guide falling coins to the pay tray.

4.8 Daily Checks:

- Check the machine is clean inside and outside
- Check all the lamps are working.
- Check pusher pads are moving.
- Check coin chutes are clear of any jammed coins or foreign matter.

Machine description and Coin prime.

This manual refers to the the Scorpion 5 processor Input/Output Allocations throughout. Please note that

Position 1 refers to the Left-hand Bed (looking at the machine from the front)

Position 2 refers to the Right-hand Bed (looking at the machine from the front)

5.1 Machine Description & Product Overview

This design utilizes a twin player pusher cabinet with a 32" TFT display unit on top. The player uses the sliding coin entry to insert coins on to their respective play-field. Each coin entry has a micro-switch, which detects the coin.

The coins falling onto the moving bed are pushed off the play-field. Coins can exit either via lose chutes either side of the main field, or fall off the front. These "winning" coins fall into the hoppers where they are 'counted', before being deposited into the cash-box.

In addition to this game being offered, additional skill comes from the player utilizing the sliding coin entry to illuminate the 8 "car" or "hat" lamps on their respective pin panels. With the pin panel illuminated in full, the screen feature is awarded.

The screen feature is played on the Monopoly Board. The player piece is moved around the board and awarded redemption tickets for landing on properties.

The screen feature game is terminated when "Go to jail" is awarded.

Please note, when the machine is switched on the count hoppers are enabled for approximately 15 seconds in order to empty them of any coins that may have been dislodged from the playfield. These coins are fed to the cashbox and are recorded on the cashbox meter.

When a player inserts a coin the hopper in the section being played is enabled. The hopper is enabled for approximately 15 seconds or for 15 seconds after the last winning coin counted by the hopper. (Also see TILT section)

Machine description and Coin prime.

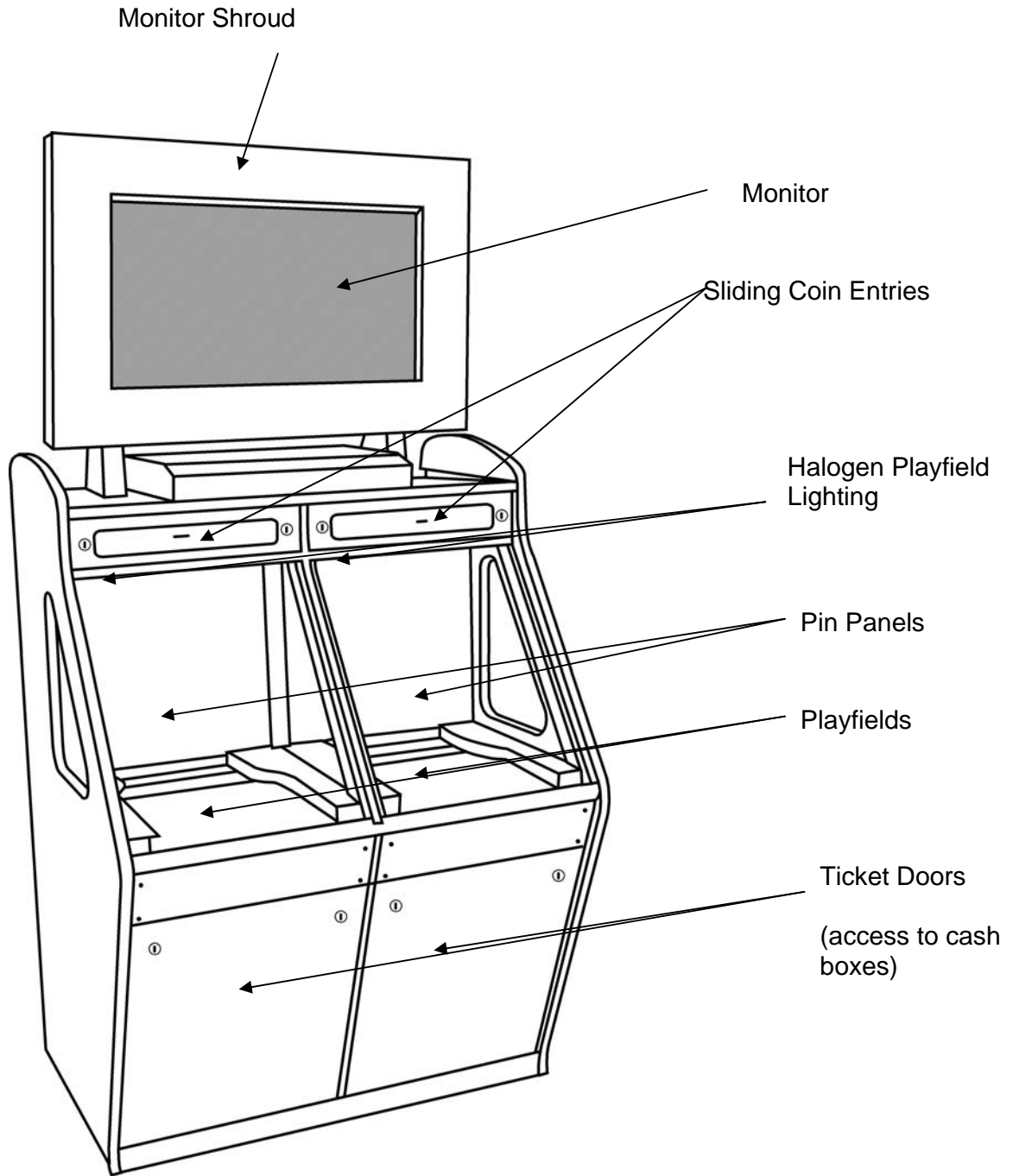

Machine description and Coin prime.

5.2 Coin floating.

Switch on the machine and make sure all is working correctly.

Carefully remove the glass doors and store in a safe position.

Spread coins over the playfield and pusher pad in each play section so that there is a build up of coins at the win chute edge.

It will be necessary to feed a number of coins through each coin slot to settle the playfield area ready for play.

Operator adjustments

6.1 Ticket Payout.

Each time a coin is inserted one or more tickets can be dispensed from the ticket dispenser, these are called “mercy ticket”. The operator using the setup menu can set the number of mercy tickets.

For each winning coin the ticket dispenser will dispense one or more tickets. The operator can adjust the number of tickets dispensed per winning coin.

When the ticket dispenser runs out of tickets (or fails to detect tickets being dispensed due to a fault) a warning lamp on the lower door illuminates and the software makes no further attempt to dispense tickets until the situation is resolved and the machine reset. The machine still operates and buffers the number of tickets owed to the player until the empty condition is cleared. (Also see TILT section).

6.2 Tilt.

There is one slam tilt assembly in each play-section located on the back of each Ticket Dispenser door.

This is accessible by removing the relevant ticket dispenser door.

This consists of a weighted contact fixed against the door panel surface, designed to detect banging of the cabinet or service door (See figure 2).



Figure 2 – Slam tilt contact.

Operator adjustments

There is one pendulum tilt assembly located inside the top of the cabinet.
(See figure 3).

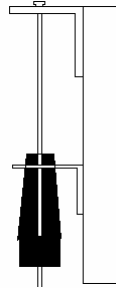

Figure 3 - pendulum tilt.

If any of the above switches are made during the operation of the machine an audible alarm is heard. The ticket dispensers are disabled and any pending tickets are cleared! The top sign illumination is switched off and during the tilt time the hoppers continue to count winning coins to the cash-box.

The length of the tilt period is adjustable by the operator (see set up menu below).

Operator adjustments

6.3 Set UpMenu

The machine is fitted with a test box, comprising of an alphanumeric display and seven switches.

ALPHANUMERIC DISPLAY						
BUTTON 1	BUTTON 2	BUTTON 3	BUTTON 4	BUTTON 5	BUTTON 6	BUTTON 7

The functions of these buttons are:

BUTTON 1 = SETUP ENTRY/EXIT

BUTTON 4 = ENTER/EXIT TEST

BUTTON 6 = STEP DOWN THROUGH OPTIONS

BUTTON 7 = STEP UP THROUGH OPTIONS

The operator presses and holds down BUTTON1 for 5 seconds to enter the setup menu.

The alphanumeric will show "SETUP MENU IN 5" and count down and then show "SETUP MENU" followed by a confirmation beep. Releasing Button1 will the show the first setup option.

The setup options are:

- VOLUME
- COIN/SWIPE
- MERCY TICKETS
- TICKETS/COIN
- TILT TIME
- TILT VOLUME
- ATTRACT TIME
- LAMP TEST

The operator can use BUTTON 6 and BUTTON 7 to step through the options which display there current settings. If the operator wishes to change the setting he presses BUTTON 4 and then can setup through the possible settings for that option, pressing BUTTON 4 will save the new setting and return to the menu. Pressing BUTTON 1 twice will exit the setup menu.

Operator adjustments

NB the operator must use BUTTON7 to save any changes to the options. The alphanumeric will confirm the change to the option.

Currently the options can be set thus

VOLUME	-	1-100	Minimum/Maximum volume
MERCY TICKETS	-	0-10	0 = No Tickets, a max of 10 per coin
TICKETS/COIN	-	0-10	0 = No Tickets, a max of 10 per coin
TILT TIME	-	10-30	10-30 seconds in steps of 5 seconds
ATTRACT TIME	-	0-360	Time between OCD sounds (0=disable)
LAMP TEST	-		All lamps on the pin panels flash

6.4 Adjustment of “lose” hole size.

The “lose” holes are located one each side of the front edge of the play-field, are factory set. It is not recommended changing this setting. Other lose hole adjusters are within the cash box.

6.5 Playfield Riser.

Located at the play-field front edge. The angle of the triple riser is set.

6.6 Ticket Dispensers. – Scorpion 5 MPU Connections

Please note that the dispenser interface boards (36.045.001) are fitted to the rear of each ticket door.

Ticket Dispenser Drive	Plug D Pin 9
Ticket Notch Sensor	Plug C Pin 8

Operator adjustments

6.7 Azkoyen cctalk U+ Hoppers (Payout & Count) – Scorpion 5 MPU Connections

Cctalk	Plug Q Pin 1
0 volts	Plug Q Pin 4
+24 volts	Plug Q Pin 10

Each playing section has

- 1 x Serial “COUNT” hopper with passive overflow
- 1 x Serial “PAYOUT” hopper

Cctalk	Address 3	Dil Sw 3 ON	LH Playing Position Payout Hopper
Cctalk	Address 4	Dil Sw 3 ON	LH Playing Position Count Hopper
Cctalk	Address 5	Dil Sw 3 ON	RH Playing Position Payout Hopper
Cctalk	Address 6	Dil Sw 3 ON	RH Playing Position Count Hopper

6.8 Lamp Matrix – Scorpion 5 MPU Connections

	Data 15	Data 14	Data 13	Data 12	Data 11	Data 10	Data 9	Data 8	Data 7	Data 6	Data 5	Data 4	Data 3	Data 2	Data 1	Data 0
Strobe 0									Top Car 2 nd LH	Top Car 2 nd LH	Top Car 2 nd LH	Top Car 2 nd LH	Top Car LH	Top Car LH	Top Car LH	Top Car LH
Strobe 1									Top Car RH	Top Car RH	Top Car RH	Top Car RH	Top Car 2 nd RH	Top Car 2 nd RH	Top Car 2 nd RH	Top Car 2 nd RH
Strobe 2									Bottom Car 2 nd LH	Bottom Car 2 nd LH	Bottom Car 2 nd LH	Bottom Car 2 nd LH	Bottom Car LH	Bottom Car LH	Bottom Car LH	Bottom Car LH
Strobe 3									Bottom Car RH	Bottom Car RH	Bottom Car RH	Bottom Car RH	Bottom Car 2 nd RH	Bottom Car 2 nd RH	Bottom Car 2 nd RH	Bottom Car 2 nd RH
Strobe 4																Car Ticket Out RED lamp
Strobe 5																
Strobe 6																
Strobe 7																
Strobe 8	Top Hat 2 nd LH	Top Hat 2 nd LH	Top Hat 2 nd LH	Top Hat 2 nd LH	Top Hat LH	Top Hat LH	Top Hat LH	Top Hat LH								
Strobe 9	Top Hat RH	Top Hat RH	Top Hat RH	Top Hat RH	Top Hat 2 nd RH	Top Hat 2 nd RH	Top Hat 2 nd RH	Top Hat 2 nd RH								
Strobe 10	Bottom Hat 2 nd LH	Bottom Hat 2 nd LH	Bottom Hat 2 nd LH	Bottom Hat 2 nd LH	Bottom Hat LH	Bottom Hat LH	Bottom Hat LH	Bottom Hat LH								
Strobe 11	Bottom Hat RH	Bottom Hat RH	Bottom Hat RH	Bottom Hat RH	Bottom Hat 2 nd RH	Bottom Hat 2 nd RH	Bottom Hat 2 nd RH	Bottom Hat 2 nd RH								
Strobe 12								Hat Ticket Out RED lamp								
Strobe 13																
Strobe 14																
Strobe 15																

6.9 Switch Matrix – Scorpion 5 MPU Connections

Plug M	INPUT1 D0	INPUT2 D1	INPUT3 D2	INPUT4 D3	INPUT5 D4
	pin 1 BLACK	pin 2 BLACK	pin 3 BLACK	pin 4 BLACK	pin 5 BLACK
Strobe 1	Player 1 Coin 1	Player 1 Coin 2	Player 1 Coin 3	Player 1 Coin 4	Player 1 Slam Switch
Strobe 2	Player 2 Coin 1	Player 2 Coin 2	Player 2 Coin 3	Player 2 Coin 4	Player 2 Slam Switch
Strobe 3	Player 1 Front Door	Player 2 Front Door	Tilt		
Strobe 4					
Strobe 5					
Strobe 6					
Strobe7					
Strobe 8					
Strobe 9					
Strobe 10					
Strobe 11					

	D 0	D 1	D 2	D 3	D 4
Strobe 18	On CPU	Pin 11	Pin 12	Pin 13	Pin 14

Operator adjustments

6.10 Vortex Layout / Connections

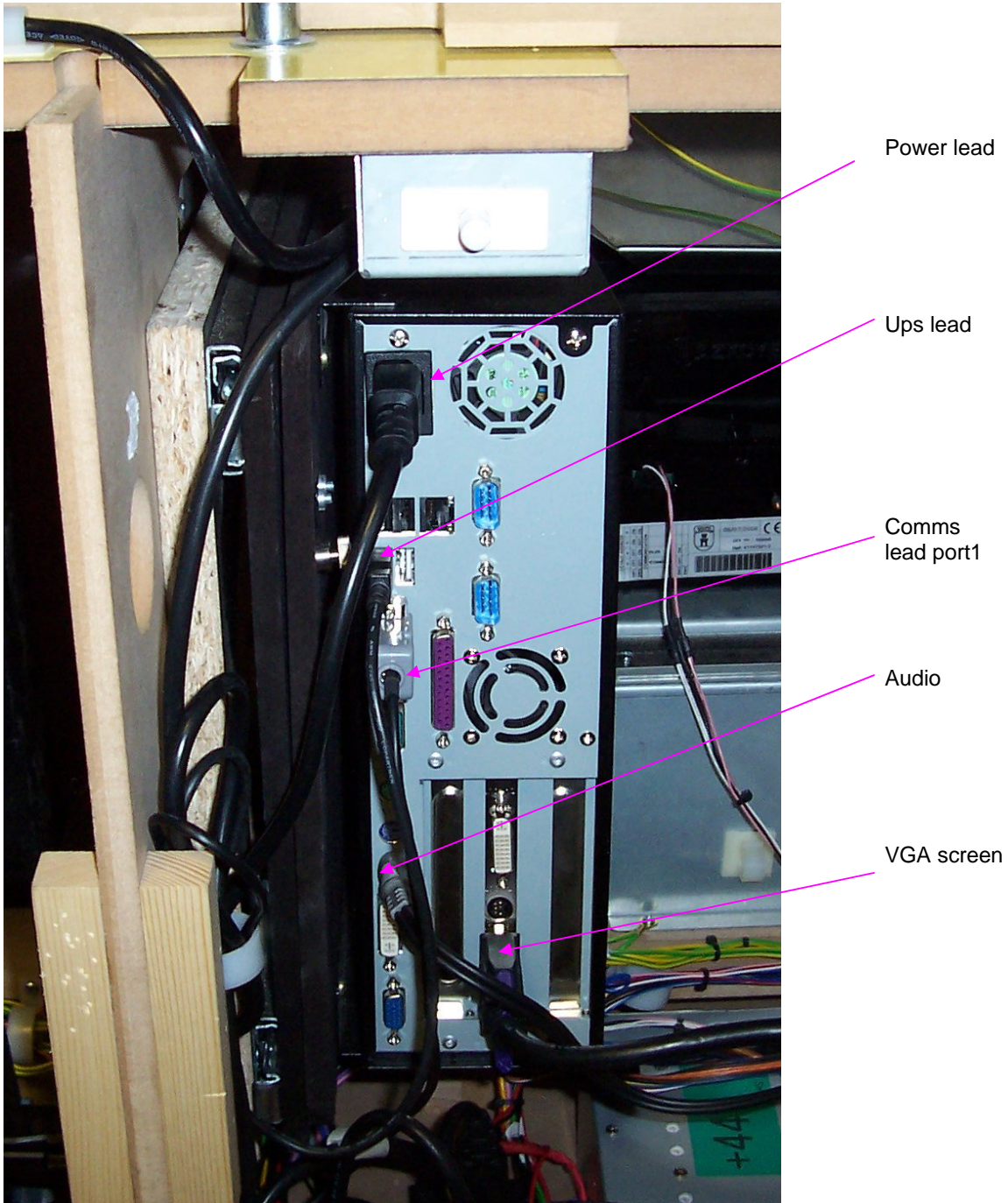

6.11 PLUG LOCATIONS

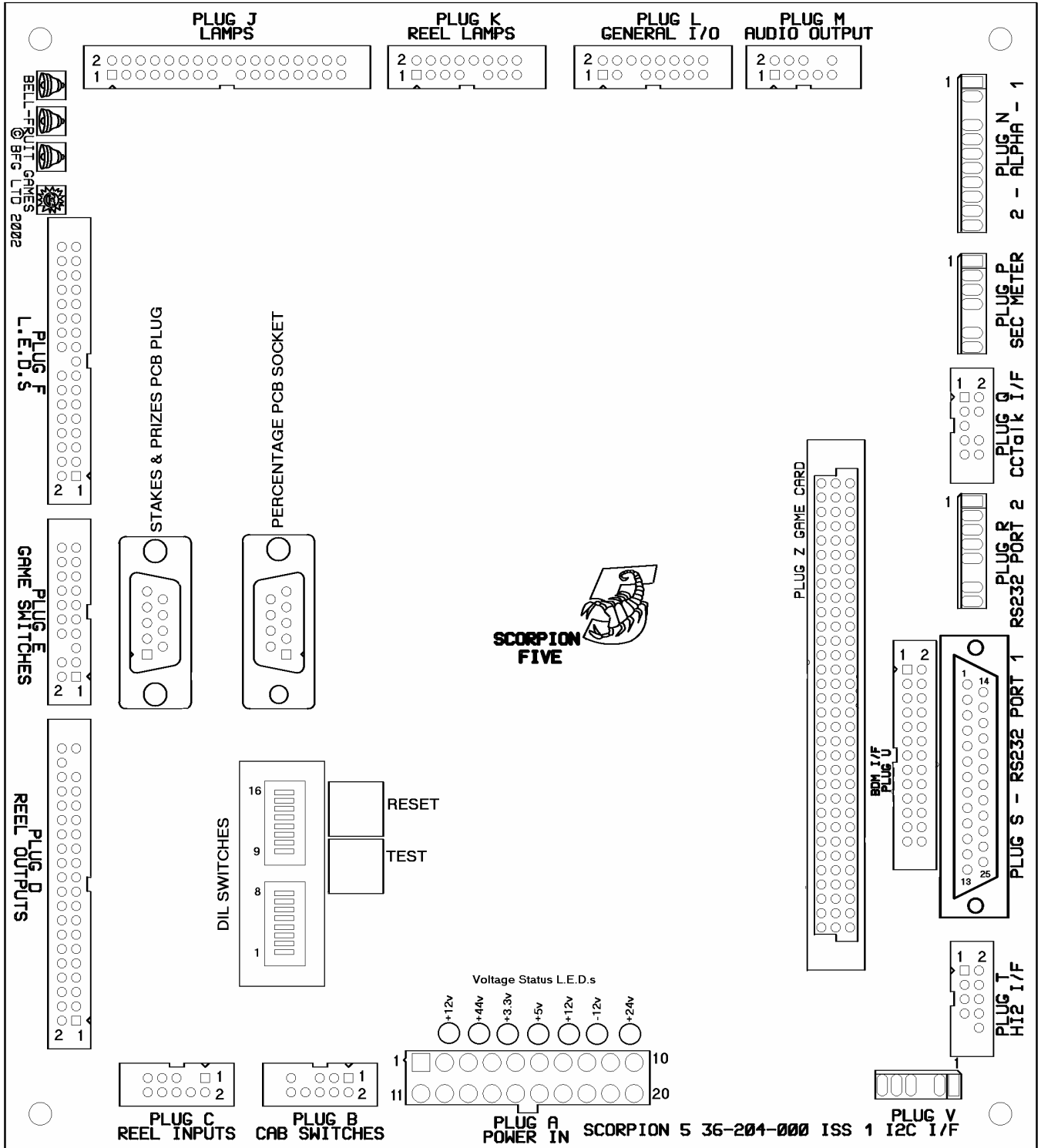

PLUG A
Power in

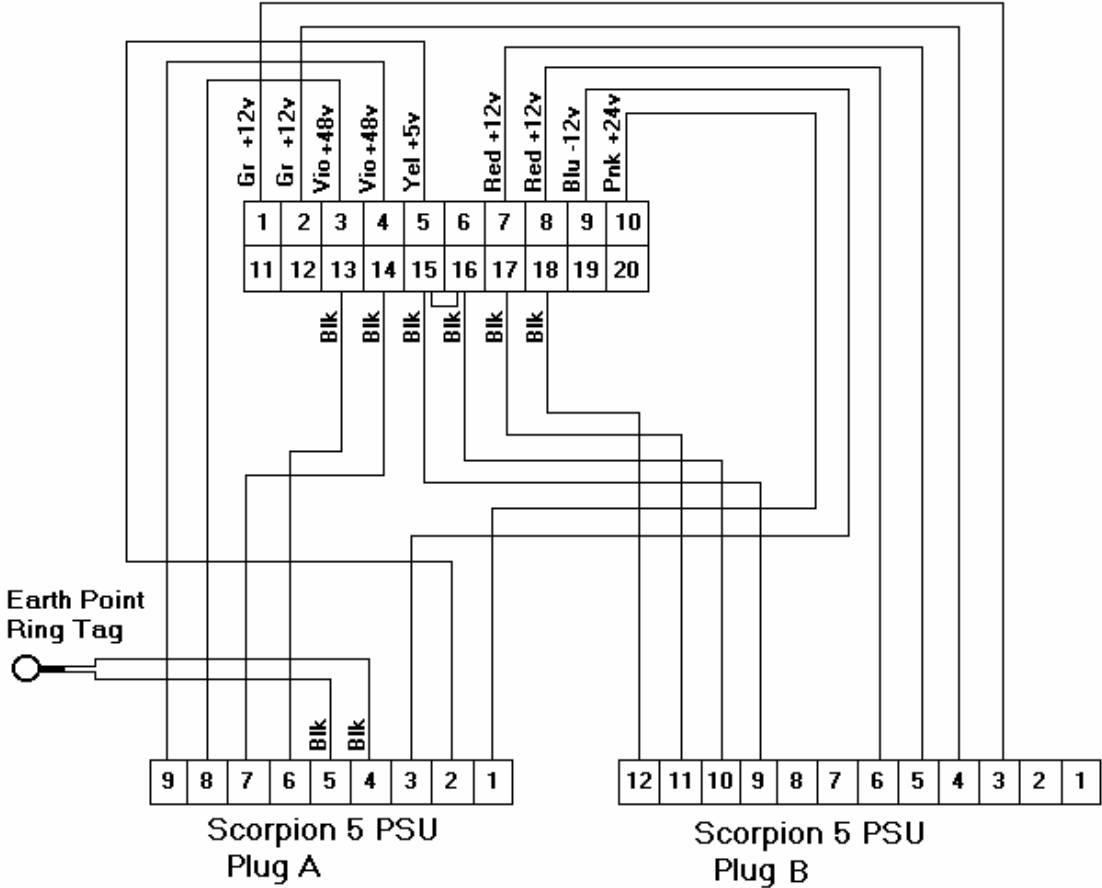

PLUG B
Door Switches

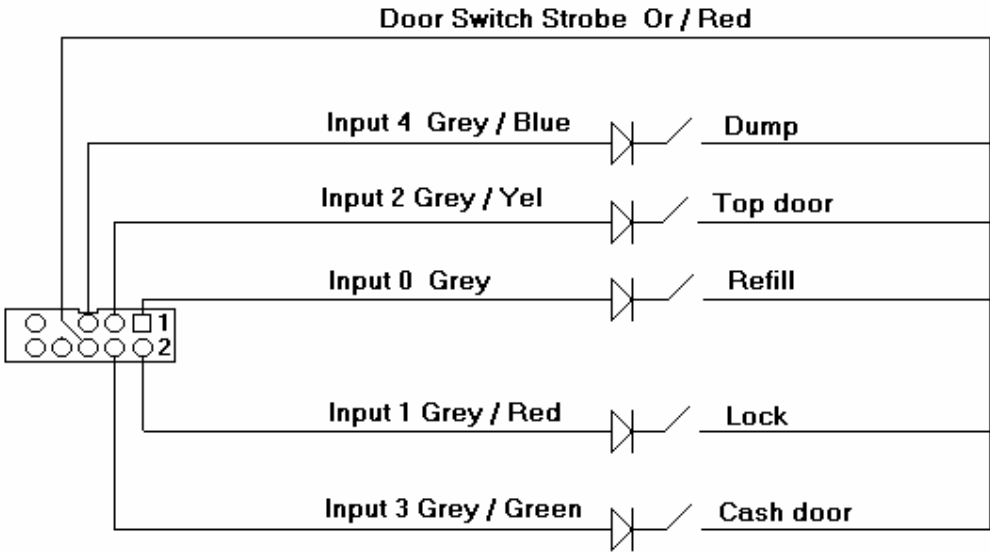

PLUGS C , D and K

Reels

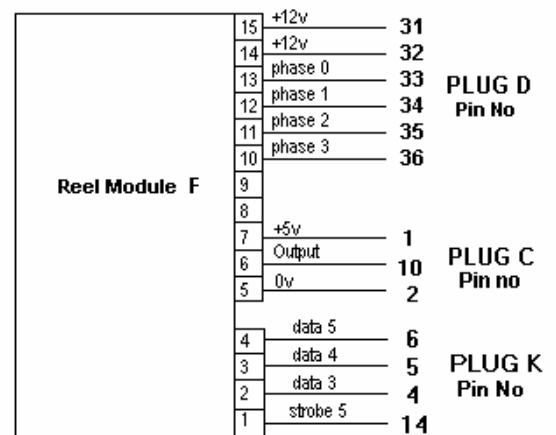
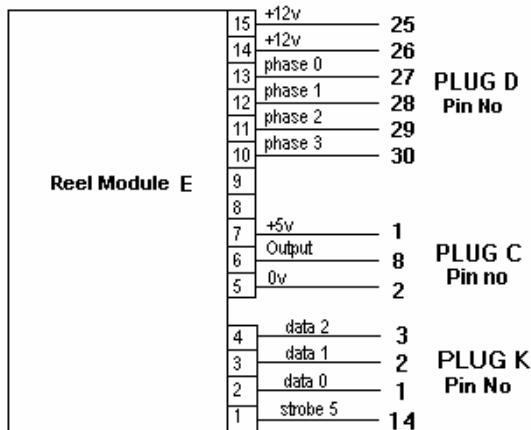
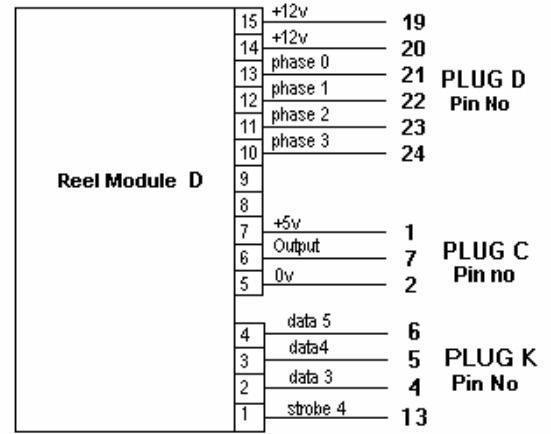
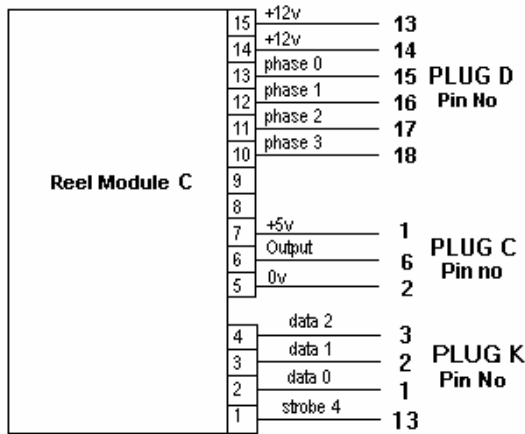
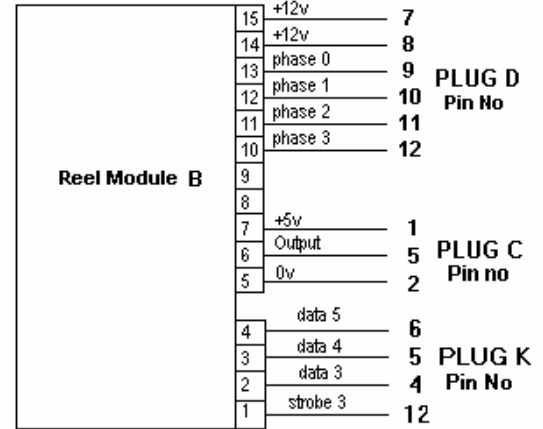
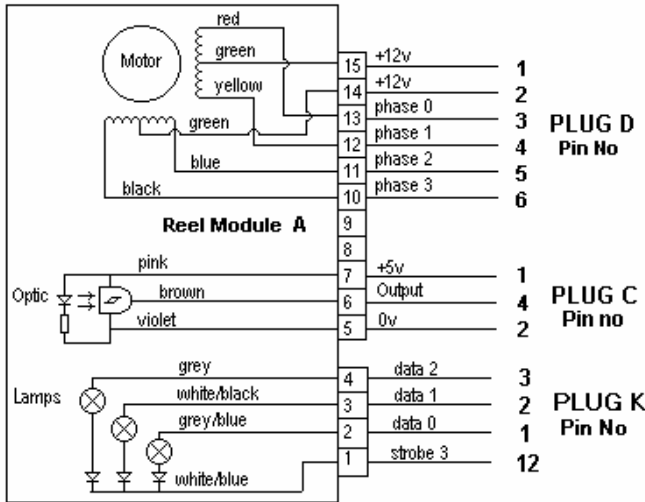

PLUG E

Switch Inputs

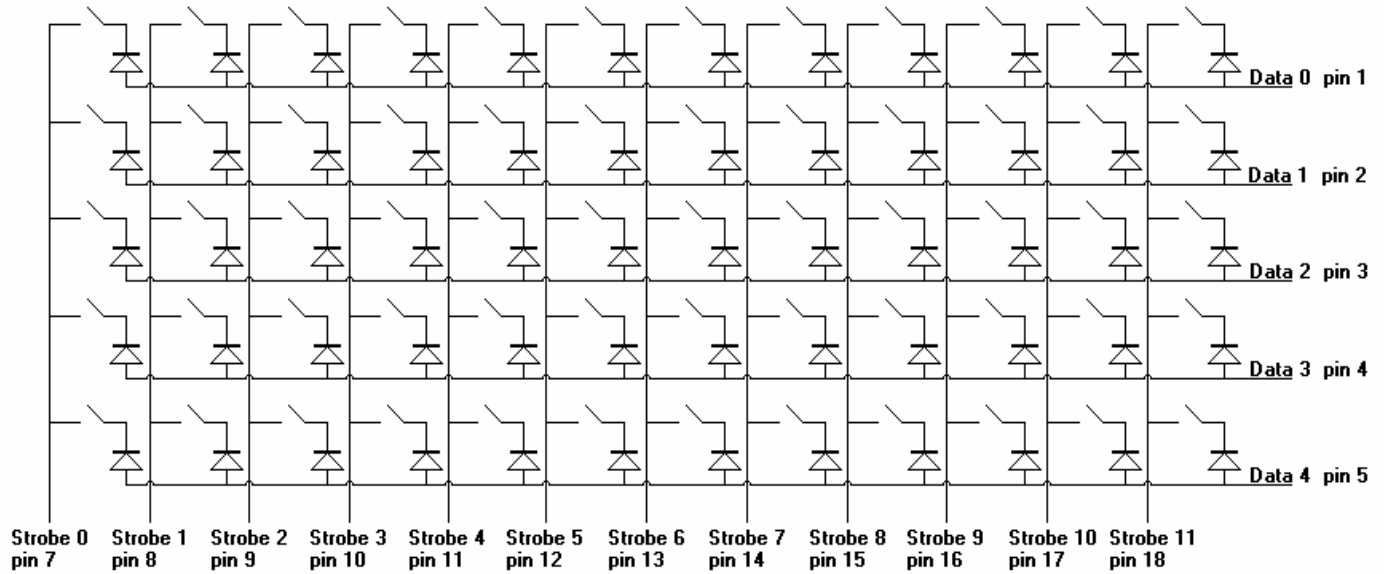

PLUG F

L.E.D 's

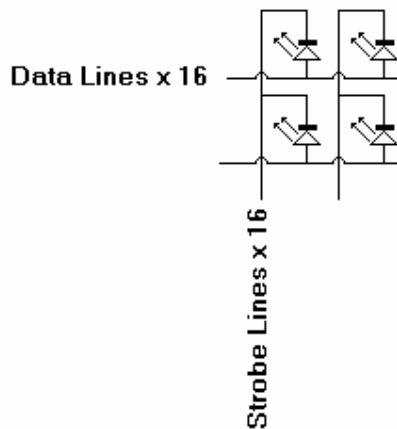

Pin 1 Data 0	Pin 19 Strobe 0
Pin 2 Data 1	Pin 20 Strobe 1
Pin 3 Data 2	Pin 21 Strobe 2
Pin 4 Data 3	Pin 22 Strobe 3
Pin 5 Data 4	Pin 23 Strobe 4
Pin 6 Data 5	Pin 24 Strobe 5
Pin 7 Data 6	Pin 25 Strobe 6
Pin 8 Data 7	Pin 26 Strobe 7
Pin 9 Data 8	Pin 27 Strobe 8
Pin 10 Data 9	Pin 28 Strobe 9
Pin 11 Data 10	Pin 29 Strobe 10
Pin 12 Data 11	Pin 30 Strobe 11
Pin 13 Data 12	Pin 31 Strobe 12
Pin 14 Data 13	Pin 32 Strobe 13
Pin 15 Data 14	Pin 33 Strobe 14
Pin 16 Data 15	Pin 34 Strobe 15

NEW LAMPS BREAK OUT BOARD

36 - 213 - 002 - 000

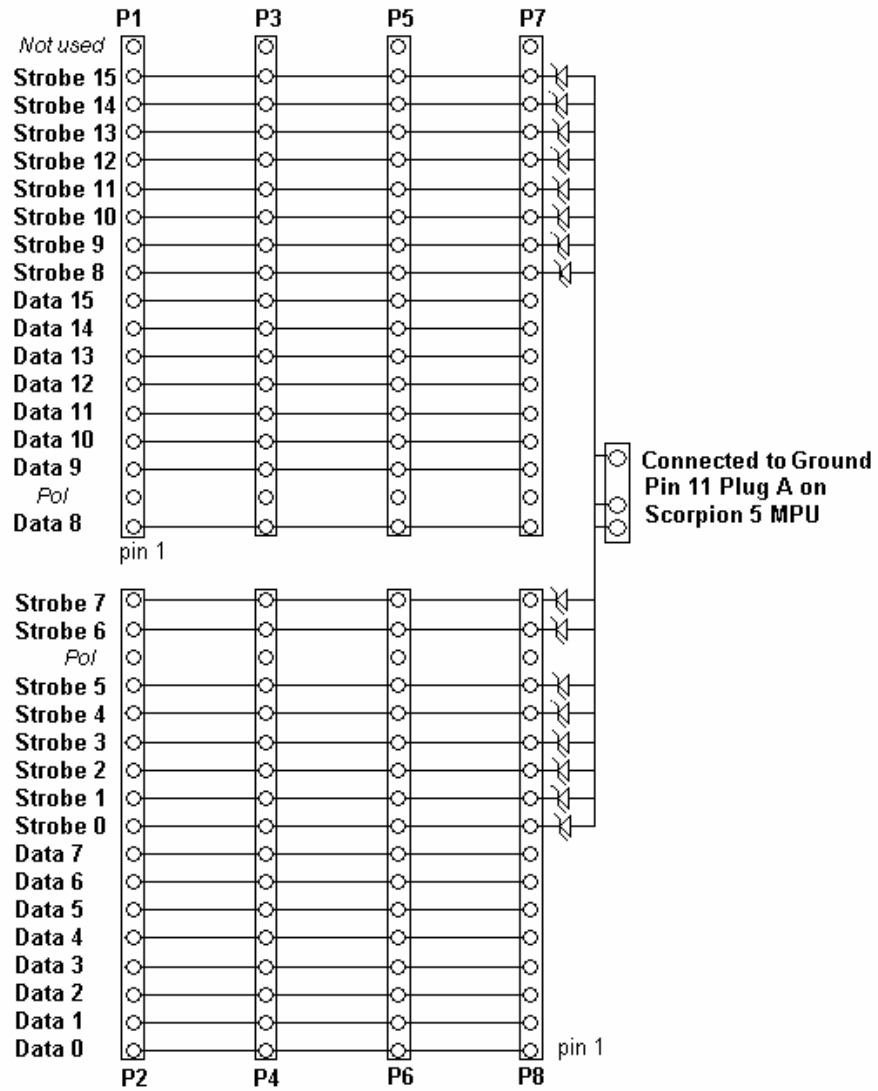

LAMPS BREAK OUT

PLUG J

Lamps

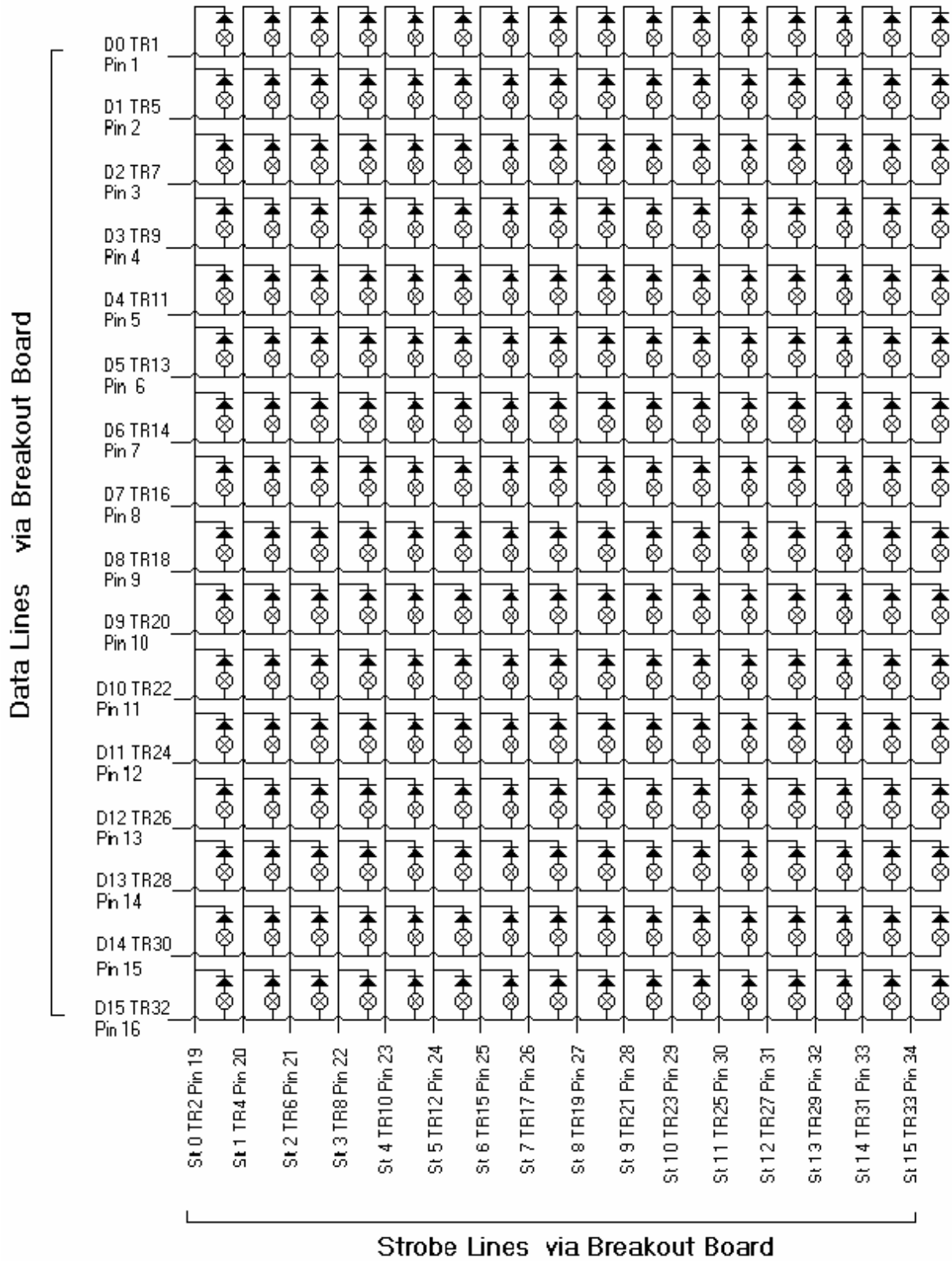

PLUG M

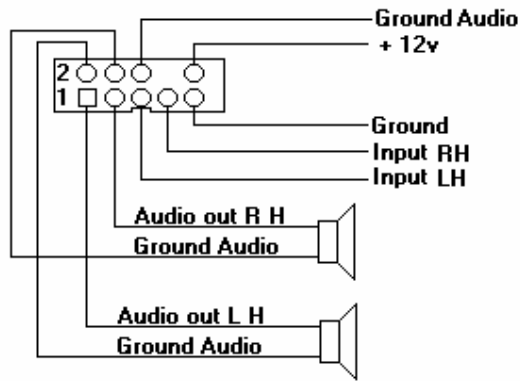

PLUG N Alpha Display

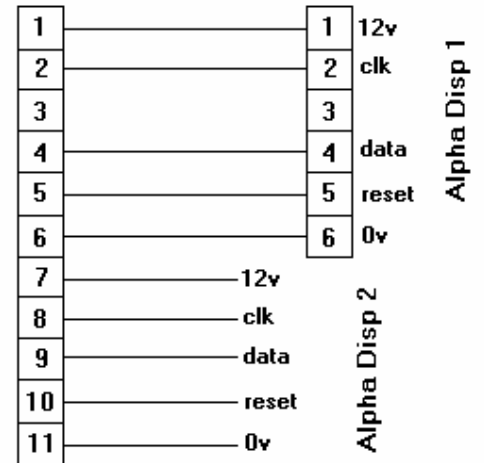

Audio

PLUG P SEC Meter

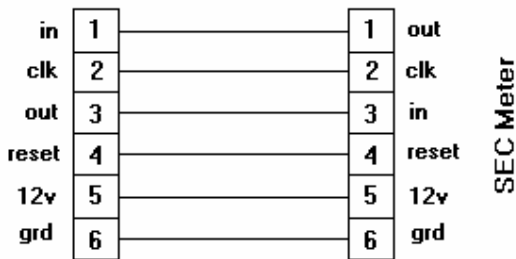

PLUG S RS 232 PORT

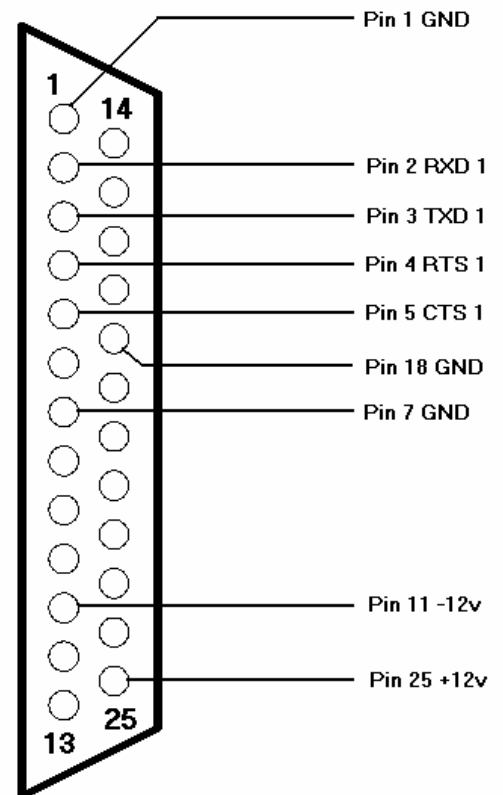

PLUG R RS 232 port 2

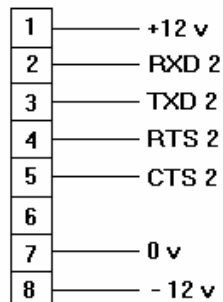

HOPPER WIRING

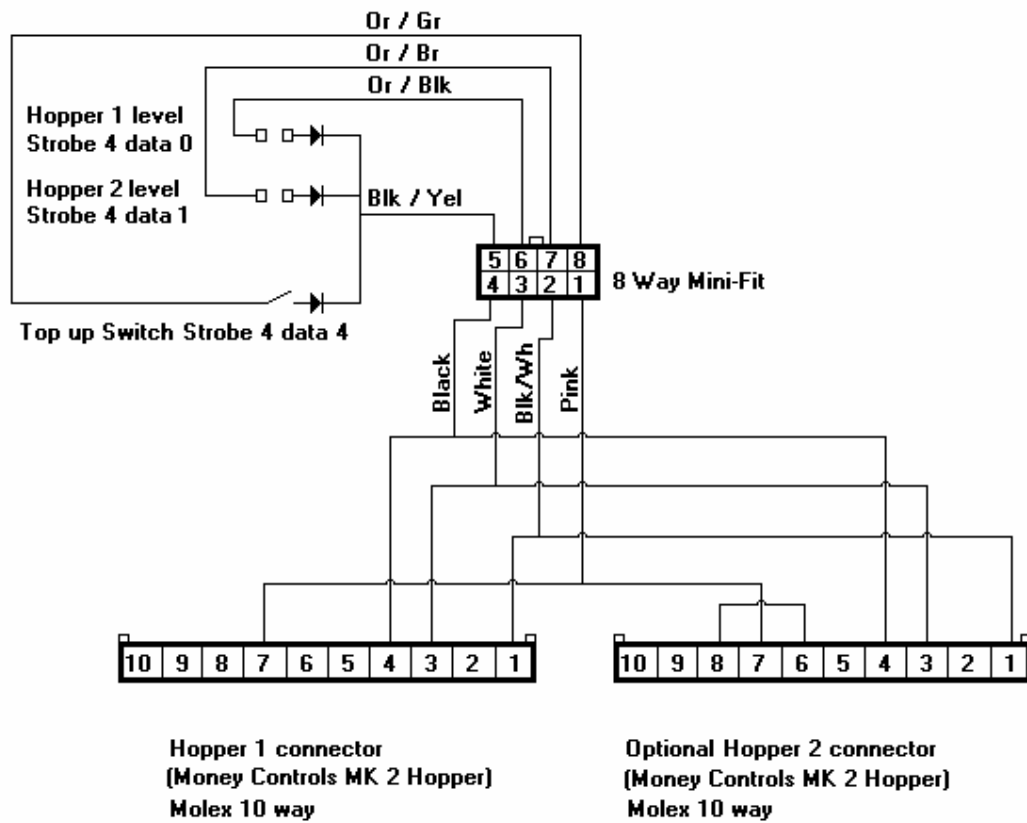

CCTalk Wiring

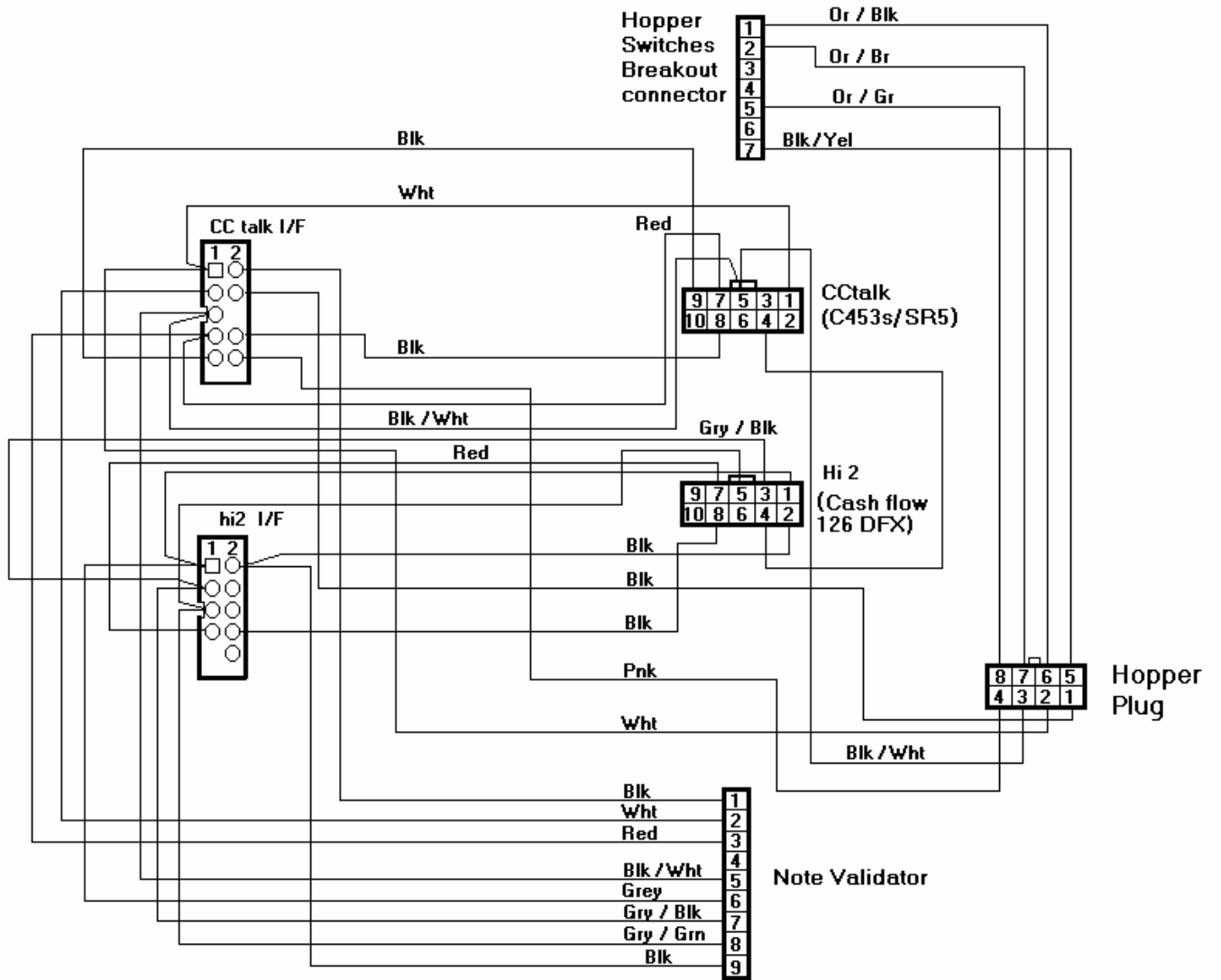

Fault - finding guide.

7.1 The machine does not work

Check

- Mains wall outlet is switched “on”.
- “On/off” switch in play section 1 is switched “on”.
- Damage to mains inlet cable.
- Power Supply Unit Fuse.

7.2 Pusher motor not running.

Check

- Power Supply Unit Fuse.

7.3 The tilt does not work.

When the machine is tilted an audible alarm is heard. The ticket dispensers are disabled and any pending tickets are cleared! The top sign illumination is switched off and during the tilt time the hoppers continue to count winning coins to the cash-box.

Check

- The tilt contacts are not dirty or so far apart they do not touch when the machine is banged.
- The cable connected to every tilt contact ending up at the tilt detects input .

7.4 The tilt will not stop.

Check

- The tilt contacts are not bent together.
- The pendulum tilt is operating

Fault - finding guide.

7.5 No ticket pays out

Check

- There are tickets at ticket dispenser.
- There are no ticket jams.
- Electrical connections to ticket dispenser.
- Check the center perspex micro switch or loom is all working.
- Check the coin count hopper is functioning correctly

7.6 The halogen lamps do not work.

Check;

- The fuses and wiring connections.

Machine BOM (Illustrated)



**Pin Panel
(CAR)**
91.021.232



**Pin Panel
(HAT)**
91.021.452



Playfield Divider LH
91.021.233



Playfield Divider RH
91.021.235



Playfield Divider Centre
91.021.234



Ticket Decal
91.021.237



Door Panel
91.021.236

Machine BOM

<u>Part Number</u>	<u>Description</u>	<u>Quantity</u>
36045001	Pcba Entropy 2000 Interface	2
36063002	PCBA Graphic Display Panel (Var brightness)	1
36205001	Pcba Game Card Scorpion 5	1
36213001	Pcba Lamp Breakout Scorpion 5	1
36220001	Pcba Scorpion 5 Mpu New Lamp Circuit	1
36240001	Pcba Sc 5 Switches Breakout	1
40051320	M3 X 20mm M/C Screw Countersunk Pozi	28
40051410	M4 X 10mm M/C Screw Countersunk Pozi	8
40053410	M4 X 10mm Hex Head Set Screw Gr 8.8 Bzp	2
40053420	M4 X 20mm Hex Head Set Screw Gr 8.8 Bzp	2
40053516	M5 X 16mm Hex Head Set Screw Gr 8.8	4
40056320	M3 X 20mm Set Screw Pan Head Pozi	42
40061512	M5 X 12mm C/Sunk Head Machine Screw	4
40061612	M6 X 12mm Csk Head Pozi M/C Screw	8
40085512	M5 X 12mm Pan Head Tamperproof Torx Screw	1
40131616	M6 X 16mm Hexagon Headed Bolt	4
40131650	M6 X 50mm Hex Head Bolt	1
40139050	M5 X 10mm Allen Head Grub Screw	2
40326	"No.6 X 1/2"" Pan Head" Pozi Self Tap Screw	20
40513	"No.6 X 5/8"" Countersunk" Pozi Wood Screw	6
40620605	No6x1/2 Pan Hd Tamper Proof W/Screw	6
40626414	No.4x3/4 Rd Hd Pozi Wood Screw	4
40626610	"No.6 X 3/8"" Pan Head" Pozi Self Tap Screw	2
41133	Diode In4001	2
41221	Fuseholder 20 X 5mm Panel Mounted	1
41685	Heat Shrink Sleeve	6
41709	45 Deg Angle Spade Terminal Amp	2
43214050	M5 Spring Washer Singlecoil Square	5
43214060	M6 Spring Washer	4
44012066	"P Clip 1/4"	2
44055095	Cable Clip Self Adhesive9.53mm Brandau Acc-02	4
44112521	Cable Tie 144mm Long Ea Insuloid Ti8i	7
48011101	Plastic Rivet 4mm Dia Moss 39158 Or 32517	15
48811102	"Lock, Cam & Washer"	2
48811103	"Lock, Cam & Washer"	2
49412001	Blind Hole Support Richco	16
49412035	Pcb Support Rich Srschs-M4-12-01	4

Machine BOM

<u>Part Number</u>	<u>Description</u>	<u>Quantity</u>
49412036	M4 Hex Nylon Nut Richco Hn-M4-01	4
49412042	Pcb Support Richco Srlcbs-7-01	6
49412114	Spacer Self Retaining Richco Ref Ss8-2	2
49412144	Spacer 6.4mm X 4.5mm I/D Richco Ref Ss8-2	4
49412228	Barbed Push Fastener Richco Bpf-F4410	10
49420028	Hexagon Nylon Spacer G&B Hnp30-A-M3x12mm	6
51520335	'U' Plus Hopper Medium Bowl Azkoyen	2
51730011	Fan Terminated Ea110/120v	2
51900016	Motor 105v 40w 60hz 31rpm Crouzet 806670	1
52292734	7 Digit Counter Grey12v Oem	6
52910150	Speaker 4 Ohms Westra Kf120-304	2
53100009	Entropy 2000 Ticket Dispenser Td-963cr	2
53713355	Lighting Transformer Tt2317	1
54000315	4w Distribution Block	1
54000390	3 Pin Mains Inlet Plug Rs 195-912	4
54010110	Scotchlok Ug Connector	4
54761170	11 Way Wafer 4030-11bj .1 Interconnecting	2
54800050	"Polarising Key 0.1" Molex 0150 4-0292	4
54861170	11 Way Housing .1 Idc A-7690s C11 38-00-2401	2
54900211	Fuse 2 Amp 20mm X 5mm Glass Anti Surge	1
55806302	"Insulating Sleeve 1/4" I/D Amp 154509-44509	3
55806304	Insulating Boot Type C Mains Filter	2
56129009	M262 Dichroic Lamp 12v 20w Cool Beam	4
57330000	Microswitch Otehall Bb1/R-S10	8
57520010	Push Switch Double Pole Cherry Ue79-6 8a	3
57611002	Slam Tilt Switch 22-2201-11	2
6000310	M3 X 10mm Pan Head Pozi Screw	10
6000410	M4 X 10mm Pan Head Pozi Screw	16
6000412	M4 X 12mm Pan Head Pozi Screw	4
6010310	M3 X 10mm Countersunk Head Pozi Screw	3
62003nn	M3 Nyloc Nut	64
62004hn	M4 Hex Nut	16
62004nn	M4 Nyloc Nut	16
62005hn	M5 Hex Nut	5
62006hn	M6 Hex Nut	9
62103is	M3 Shakeproof Washer	6
62103nd	M3 Plain Washer	66

Machine BOM

<u>Part Number</u>	<u>Description</u>	<u>Quantity</u>
62104is	M4 Shakeproof Washer	8
62104nd	M4 Plain Washer	26
62105ld	M5 Washer	4
62106nd	M6 Plain Washer	4
78500006	Mains Filter Schaffner Fn9222r-6-06	1
90307068	Plate Fan Vent Grill	2
90307484	Plate Fan Mounting	2
90442238	Tilt Weight	1
90442242	Spacer	36
90520118	Plate Coin Entry Back	2
90520175	Base Scorpion 5 Mpu	1
90520176	Cover Scorpion 5 Mpu	1
90520177	Plate Scorpion 5 Mpu Cover	1
90520301	Plate Coin Entry Slide	2
90520946	Plate Pcb Slot Cover	1
90520955	Chassis Psu	1
90520991	Plate Pusher	2
90520993	Plate Motor Mounting	1
90520996	Winchute	2
90521009	Plate Accuride Slide Fixing	4
90521027	Divider Rundown	1
90521028	Cashbox	2
90521032	Tray Coin Entry Trash	2
90623059	Bezel Coin Entry0.984 Token	2
90623194	Runners Telescopic Slide Accuride Cz0115-1556u	2
90623202	Pusher Drive Channel	1
90623204	Spacer Accuride Slide	1
90623205	Drive Arm	1
90623206	Spacer Motor Plate	4
90623207	Ball Bearing	1
90623217	Extrusion Glass Door Retainer	2
90623218	Extrusion Ptfе Retainer	2
90623374	Weight Wire	1
90623375	Bracket Tilt Weight Contact Large Brkt	1
90850316	Bracket Transformer Mounting	1
90850391	Bracket Hopper Support	2
90850433	Bracket Coin Deflector	2

Machine BOM

<u>Part Number</u>	<u>Description</u>	<u>Quantity</u>
90850513	Bracket Hopper Mounting	2
90851015	Bracket Single Riser	2
90851029	Bracket Retainer	2
90851030	Bracket Coin Door Glass Retaining	2
90851032	Bracket Cashbox Chute Twin Tft Pusher	2
90851055	Bracket Perspex Support Bottom	4
90851056	Bracket Rh Divider Side Plate	2
90851057	Bracket Lh Divider Side Plate	2
90851062	Bracket Rundown	2
90851063	Bracket Halogen Lamp	4
90851065	Bracket 3 Piece Riser	2
90857577	Bracket Mech Location	2
90866632	Bracket Tilt Wire Support Small Brkt	1
90873610	Bracket Momentary Switch	2
91010147	Infill Block	4
91010148	Coin Guide	6
91010149	Coin Guide Long	4
91010150	Centre Guide	6
91010151	Outer Guide	4
91010209	Front Panel Monopoly Tft 2pp	2
91010210	Side Strip Monopoly Tft 2pp	4
91010218	Skimmer Monopoly Tft 2pp	4
91021232	Car P/Panel Back Perspex Monopoly Tft 2pp	1
91021233	Playfield Divider Lh Monopoly Tft 2pp	1
91021234	P'field Divider Centre Monopoly Tft 2pp	1
91021235	Playfield Divider Rh Monopoly Tft 2pp	1
91021236	Tckt Door/Side Panel Dec Monopoly Tft 2pp	2
91021237	Ticket Decal Ea Monopoly Tft 2pp	2
91021452	Hat P/Panel Back Perspex Monopoly Tft 2pp	1
91451495	Mpu Insulation Plate	1
91451542	Side Window Panel	2
91682506	Slide Block	2
91682520	Ptfe Block	2
91682529	Pusher Strip	2
91771354	Test Box Vac Forming	1
91771355	Test Box Cover Vac Forming	1
91802169	Chute Cashbox Twin Tft Pusher	2

Machine BOM

<u>Part Number</u>	<u>Description</u>	<u>Quantity</u>
91891333	Grill Fan/Speaker	2
92752343	'Coin In' Label	1
92752344	'Ticket Out' Label	1
92752364	'Winning Coins' Label	1
92766078	Coin Out Label	1
92931049	Glass Door2 Player Tft Pusher	2
94849152	Runner Cashbox Guide	4
94895081	Tilt Board	1
96832569	Iec 320 Skt To Iec 320 Plug 2m Lead	2
96832606	Mains Lead UI So1.Co2.Eo2.06.B	1
96832613	Iec Plug To Iec X2 Socket - 507-9860	1
96861729	200mm Earth Link UI	1
96861730	400mm Earth Link UI	4
96861731	650mm Earth Link UI	1
96861737	Psu Live Link Assy UI	1
96861738	Psu Earth Link Assy 150mm UI	1
96876119	Hal Lamp Holder Harness UI	2
96876367	Lamps Interface Harness Scorpion 5	1
96876520	Top Box Test Harness	1
96876783	Tt2317 Transformer Outlet Harness	1
96877172	Sc 5 To Switch Breakout Harness	1
96877373	Pc Psu Harness 5 Gaming	1
96877408	Door Harness	1
96877454	Main Cabinet Loom Monopoly Tft 2pp	1
96877455	Halogen Lamp Harness Monopoly Tft 2pp	1
96877458	Pin Panel Harness Monopoly Tft 2pp	1
96877488	Fan Harness	1
96877489	Comms Harness	1
96912487	Vortex Ps8080 Tower	1
96941342	Psu Sanken 44volts Mk2 Sps077w-44	1
97651301	Double Ticket Bin	2
97854317	Mains Plate & Stud	4
97953831	Isolating Switch Bracket & Stud	1
99895209	Cpu Lh Side Panel Assy	1
99895240	Pusher Panel Assembly	1
99955170	Cabinet Ga Twin Tft Pusher	1