

KABOOM

Getting Started

Operation & Service Manual

***Read this manual before use**



General Remark

If you encounter any difficulties or if you need support on how to update and/ or install your KABOOM product, we invite you to contact your local distributor or reach us at info@adrenalineamusements.com or by calling our support line (+450.932.4205).



Adrenaline Amusements Team

For Further Assistance

North & South America

Global VR (Tech Support)
2350 Zanker Road, San Jose, CA
95131, United States
Tel: 408.597.3435
FAX: 408.597.3437
www.globalvr.com

Table of Contents

Chapter 01 – Introduction

Preface	04
Safety	05
FEC Notice (United States)	06

Chapter 02 – Product Features

Features	07
Voltage	07
Dimensions	07

Chapter 03 – Installation

Machine Installation	08
----------------------	----

Chapter 04 – Getting Started

How to play	09
-------------	----

Chapter 05 – Operators' Menu & Game Setup

Operators' Control Menu	10
Product Default Settings	11
Accessing & Navigating the Operators' Menu	12
Volume Adjustment Menu	13
Credit Per Game Menu	13
Ticket Payout Menu	14
Suggested Payout Settings	15
Statistic Menu	16
Version Information Menu	16

Chapter 06 – Service & Repair

Computer	17
Trouble Shooting	
Video	18
Audio	18
Error Message	18
General	19
Replacement Part	
Detonator Assembly	20
Monitor Assembly	21
Opening Service Panel	21
Control Panel Assembly	22
Electronic Box Assembly	23

Chapter 07 Diagrams & Schematics

Control Card	24
Wiring & Other Distribution Diagrams	25

Chapter 1

Preface

Please read this page before preparing your KABOOM product for game play

The following safety instructions apply to all game operators and service personnel. Specific warnings and cautions will be included throughout this manual.

Use the following safety guidelines to help protect the system from potential damage and to ensure your personal safety:

- Electronic components in the game cabinet run on 115VAC 60Hz (230V/ 50Hz in most of Europe, the Middle East and the Far East delivered units).
- To help prevent electric shock, plug the system into a properly grounded power source. These cables are equipped with 3-prong plugs to help ensure proper grounding. Do not use adapter plugs or remove the grounding prong from a cable. If you must use an extension cable, use a 3-wire cable with properly grounded plugs
- To help protect your system from sudden increases and decreases in electrical power, use a surge suppressor, line conditioner or Uninterruptible Power Supply (UPS)
- Be sure nothing rests on the system's cables and that the cables are not located where they can be stepped on or tripped over.
- Keep your system far away from radiators and other heat sources
- Do not block cooling vents

Precaution for Game Operation

Adrenaline Amusements Inc assumes no liability for injuries incurred while playing our games.

Operators should be aware that certain health and physical conditions may make people susceptible to injury when playing video games, particularly when the platform is moving.

Chapter 1

Preface

Safety

Warning



To avoid electrical shock, unplug the cabinet before performing installation or service procedures.

If a power cord is damaged, it must be replaced by the equivalent power cord available from your distributor.



Adrenaline Amusement Inc assumes no liability for any damages or injuries incurred while setting up or servicing the cabinet. Only qualified service personnel should perform installation or service procedures.

Environmental Conditions

Cabinet is intended for indoor use only. Be sure to keep the cabinet dry and maintain operating temperatures of 59°-86° (15°-30°C).

Chapter 1

Preface

FEC Notices (United States)

Electromagnetic Interference (EMI) is any signal or emission radiated in free space or conducted along power or signal leads, that endangers the functioning of radio navigation or other safety service, or that seriously degrades, obstructs, or repeatedly interrupts a licensed radio communications service. Radio communications services include, but are not limited to, AM/FM commercial broadcast, television, cellular services, radar, air-traffic control, pager, and Personal Communication Services (PCS). These licensed services, along with unintentional radiators such as digital devices (Including computer systems) contribute to the electromagnetic environment.

Electromagnetic Compatibility (EMC) is the ability of items of electronic equipment to function properly together in the electronic environment. While this computer system has been designed and determined to be compliant with regulatory agency limits for EMI, there is no guarantee that interference will not occur in a particular installation. If this equipment does cause interference with radio communications services, which can be determined by turning the equipment off and on, you are encouraged to try to correct the interference by one or more of the following measures:

- Re-orient the receiving antenna
- Relocated the cabinet relative to the receiver
- Plug the game into a different outlet so that the computer and the receiver are on different branch circuits

If necessary, consult a Regulatory EMC representative of Adrenaline Amusements Inc or an experienced radio/television technician for additional suggestions. You may find the FCC interference Handbook, to be helpful. It is available from the U”S” Government Print Office, Washington, DC 20402.

This device has been tested and complies with the limits for a Class A digital device pursuant to Part 15 of the FCC Rules. These limits are designed to provide reasonable protection against harmful interference when the equipment is operated in a commercial environment. This equipment generates, uses, and can radiate radio frequency energy. If not installed and used in accordance with the instruction manual, it may cause harmful interference with radio communications. Operation of this equipment in a residential area is likely to cause harmful interference, in which case you will be required to correct the interference at your own expense.

Operation is subject to following conditions:

- This device may not cause harmful interference.
- This device must accept any interference received, including interference that may cause undesired operation.

Chapter 2

Game Features

Hardware features

- Mini ITX INTEL computer
- 1000 watts vibration platform
- Widescreen HD LCD monitor
- High performance sound system which include a 100 watts subwoofer
- High performance wind blower
- Unique detonator systems

Cabinet FACTS

- Machine Name: KABOOM Demolition co
- Machine overall dimension:
- Machine weight: 181kg

Note: this machine is intended for indoor use only

Voltage

Standard Cabinet	
Voltage	Operating
115 VAC	10 AMP
230 VAC	05 AMP

Chapter 3

Machine Installation

1. Carefully remove the Cabinet from the shipping container giving yourself enough space.
2. Remove the Floor platform and header box from the cabinet
3. Move your product to the desired location
4. Tilt the machine backward
5. Slide the platform underneath (fig 1)
6. Align the platform to have the white cones fitting within the black receptacles (fig 2)

Figure 1



Figure 2



7. Connect the shaking device by inserting the plug in the available connector (fig 3)

Figure 3



8. Bolt on the KABOOM signage on the top of your product

Chapter 4

Getting Started: How to play

As described in the game play instruction, your goal is to load all 5 TNT containers.

After inserting the requested amount of credit, the game will display the How to Play instruction: Have a look, read and listen carefully.

Using the red “T” shape detonator, stop the moving light underneath each of the TNT container displayed on the control panel. You have only five (5) tries.

Make sure not to stop the moving light underneath a container that you have already loaded.

Depending on your score (0-5 TNT containers properly loaded) you will have the chance to experience the quality of your work: enjoy the film and feel the rush of tearing down an old structure for real! Make sure to stay on the platform until you collect your ticket!

Chapter 5

Operator Menu & Game Setup

This chapter describes how to use the Operator Control Panel to navigate through the Operator Main Menu to set up your product, access earnings statistics and adjust all the game play parameters.

The Operator Control Panel

In order to access the Operator Menu, you will be requested to use the Operator Control Panel located inside the coin door

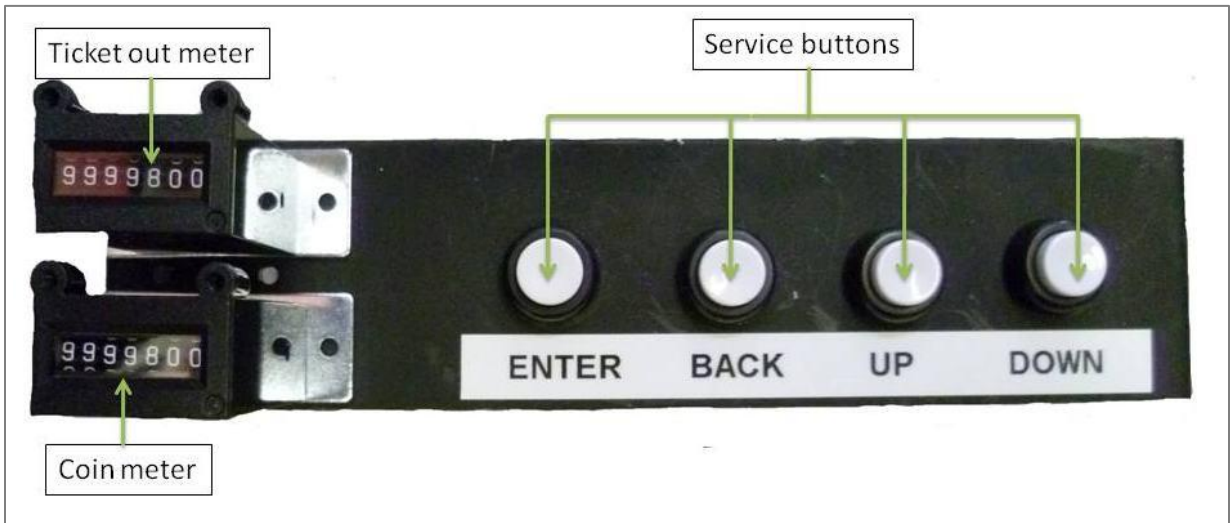

Use the services buttons to navigate the operator menu, adjust the volume, adjust the amount of credits per play, manage ticket payout and access game play statistics

Chapter 5

Product Default Settings

At all time you will have the opportunity to reset individually each parameters to its original factory settings. Factory settings for each parameters are the following:

Volume Settings	
Attract Mode Volume	1
Master Volume	7
Demolition Vibration Volume	10

Credits Setting	
Credits Per Game	2

Tickets Payout Settings	
One TNT	4
Two TNT	10
Three TNT	20
Four TNT	40
Jackpot	500
Jackpot Increment	1
Jackpot Cap	992
Jackpot Winability	100
Difficulty Level	5

Chapter 5

Accessing & navigating the Operator Menu

1. Press the ENTER service button while the game is running the Attract Mode
2. Using the UP or DOWN service buttons, navigate through the operator menu
3. Press ENTER to select the appropriate option
4. Using the UP or DOWN service buttons, change the value of the selected field
5. To escape the Operator Menu simply use the BACK service button until the menu disappears



Chapter 5

*Refer to page 6 to review how to navigate through the menu and adjust the different settings

Volume Adjustment Menu

Attract Mode Volume

Volume can be adjusted from 1 to 10

Master Volume

Adjust game play volume

Demolition Vibration Volume

Adjust the vibration of the platform during game play



Credit Per Game Menu

Credits per play

Adjust the amount of credits needed per game

Reset Coins Count

To avoid having more than 40 credit accumulated, the software will automatically locked the game if a player insert more than 40 credit all at once. (New Jersey regulation)



Chapter 5

Ticket Payout Menu

“One TNT” to “Four TNT”*

Amount of tickets dispensed depending on player’s result

•The next page feature suggested payout settings

Jackpot

Amount of tickets dispensed if the Jackpot is won

Jackpot Increment

If selected value greater than 0, the Jackpot amount will progressively increase by the selected amount for each game played, until Jackpot is won

Jackpot Cap

Maximum amount that a progressive Jackpot can reach; if reached, the jackpot will remain to its maximum value until it is won

Jackpot Win ability

Jackpot Win ability affect the odds of winning the Jackpot. The selected value represent the number of game played before affecting positively Jackpot Win Ability. A value of 0 will disable the Jackpot Winability feature.

Tickets payout	
One TNT	2
Two TNT	5
Three TNT	15
Four TNT	30
Jackpot	500
Jackpot increment	1
Jackpot cap	992
Jackpot winability	100
Difficulty level	5
Reset to factory settings	

Chapter 5

Suggested Payout Settings

The following parameters are to be used as guidance. Results may vary depending on players skill, so adjust if necessary.

Price Per Play	Reward Structure	30% Payout	40% Payout
1 CREDIT	“ One TNT ”	1	2
	“ Two TNT ”	3	5
	“ Three TNT “	8	10
	“ Four TNT “	15	20
	Original Jackpot Setting	500	500
2 CREDITS	“ One TNT ”	2	4
	“ Two TNT ”	5	10
	“ Three TNT “	15	20
	“ Four TNT “	30	40
	Original Jackpot Setting	500	500
3 CREDITS	“ One TNT ”	4	6
	“ Two TNT ”	10	10
	“ Three TNT “	25	30
	“ Four TNT “	45	60
	Original Jackpot Setting	500	500
4 CREDITS	“ One TNT ”	6	8
	“ Two TNT ”	10	20
	“ Three TNT “	30	40
	“ Four TNT “	60	80
	Original Jackpot Setting	500	500

Chapter 5

Statistics Menu

Lifetime Credit

Amount of credits inserted since the product have been original installed; this statistic cannot be reset.

Total games

Amount of games played since statistic last reset.

Total Tickets

Amount of tickets dispensed since statistic last reset



Statistics	
Lifetime credits	838
Total games	21
Total tickets	858
Average tickets per game	40
TNT 0	0.0%
TNT 1	0.0%
TNT 2	38.1%
TNT 3	33.3%
TNT 4	23.8%
Jackpot	4.8%
Reset statistics	
Last reset	30/04/10

Version Information Menu

Application's Version

Identified which version of the Game is Installed

Firmware's version

Identify which version of firmware is currently installed in KABOOM I/O Card



Versions info	
Application's version	1.005
Firmware's version	1.013

Chapter 6

Service & Repair

Computer ADR-KA-9100-00

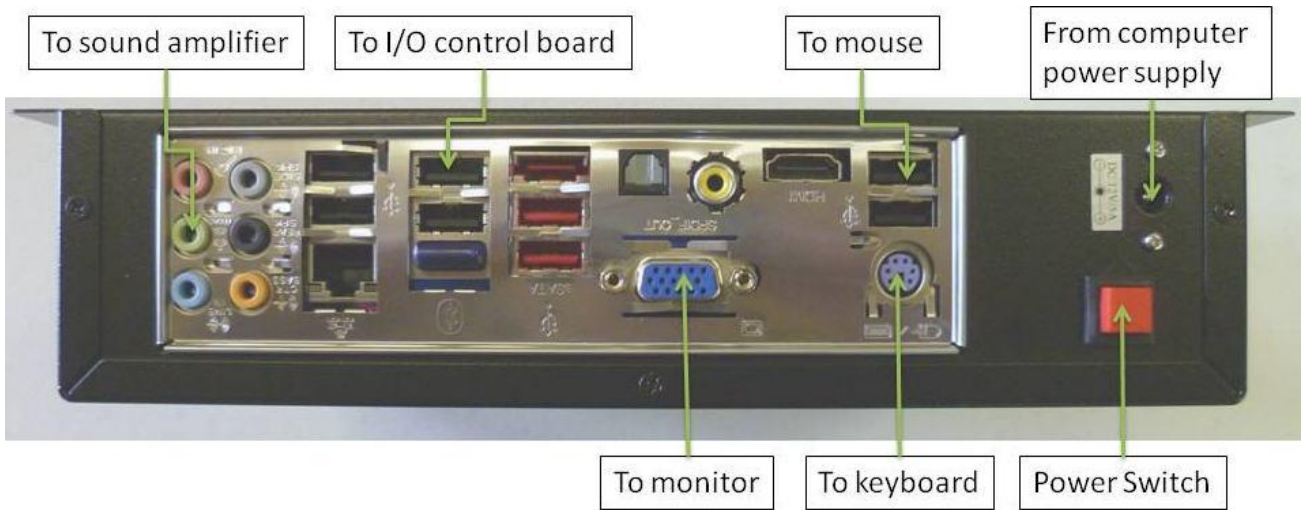

Chapter 6

Troubleshooting

Video Trouble Shooting

No picture displayed but audio is heard

Power Problem, check the power to monitor

loose or faulty connections between LCD panel and computer, make sure VGA cable is connected properly to both computer and LCD monitor

No picture and no audio is heard

No power to computer, Verify the computer is ON by the blue LED on the front of the computer. Press the RED power button. Make sure that the round power plug is well connected. Check LED on Computer external power supply. Check AC power cord from electronic box to computer external power supply.

Bios setting has changed, If the computer does not power automatically when machine is powered on, check BIOS settings AC Power on function is set to ON

Audio Trouble Shooting

Low volume

Increase the volume by pressing the menu button and adjust

Loose wire

Check 1/8 audio cable from green computer jack to sound amplifier in the electronic box. Check cables from amplifier to each speakers

Faulty amplifier

Replace Amplifier

Error Message Screens

Error when opening serial port

Check that USB cable is connected from computer to I/O board.

Chapter 6

General Trouble Shooting	
Detonator does not work	Faulty micro switch, Replace the micro switch on the button and re-test
	Faulty wiring, Disconnect the cabinet from AC power, Verify that all wires are firmly connected to the button and the Kaboom I/O board.
	Faulty Kaboom I/O board, Make sure that all connections to the PCB are firm. Replace Kaboom I/O board if faulty
Jackpot LED display does not work	Blown fuse, Replace fuse at FH2 on KABOOM I/O board (use 2.5 AMP fuse)
	Defective power supply, Check 5VDC out of power supply
	Faulty wiring, Check that all connection are firm
	Faulty Jackpot display, replace Jackpot Display
Control Panel light do not work	Blown fuse, Replace fuse at FH1 on KABOOM I/O board (use 4 AMP fuse)
	Defective power supply, Check 12VDC out of power supply
	Faulty wiring, check that all connection are firm
	Faulty control panel display board, replace board
Vibration Platform does not work	Shaker cable not connected, check is shaker is connected to the Electronic box
	Blown fuse, replace fuse at FH3 on I/O board (use 10 AMP fuse)

Chapter 6

Replacement Parts

Detonator Assembly ADR-KA-4000-01

REF	PART	NUMBER
01	Detonator Handle	KA-01-4100-00
02	Detonator Ring	KA-01-4200-00
03	Sleeve	KA-01-4300-00
04	Circle Clip 7/8	ADR-15-001-00
05	Teflon Ring	KA-01-4500-00
06	Spring	KA-01-4700-00
07	Cylinder	KA-01-4400-00
08	Bolt M8X40	ADR-15-002-00
09	Bolt M8X10	ADR-15-003-00
10	Bolt M8X16	ADR-15-004-00
11	Switch Suport	KA-01-4600-00
12	Switch With Roller	Happ 50-8018-20
13	Nut M3	ADR-015-005-00
14	Pin	KA-01-4810-00

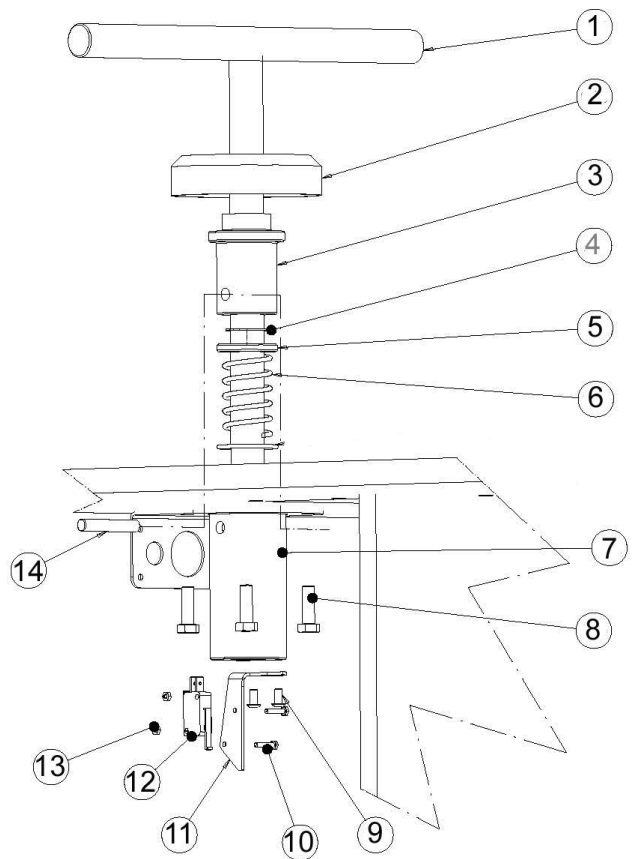

Chapter 6

Monitor Assembly

To replace the monitor remove the 3 screws on each side of the monitor case

REF	PART	NUMBER
01	Monitor Case	KA-01-1130-00
02	22" Monitor	ADR-10-001-00
03	Jackpot Holder	Ka-01-1140-00
04	Jackpot LED Board	KA-04-001-00
-	Monitor Assy	ADR-KA-1100-00
05	26" Monitor	ADR-10-001-01

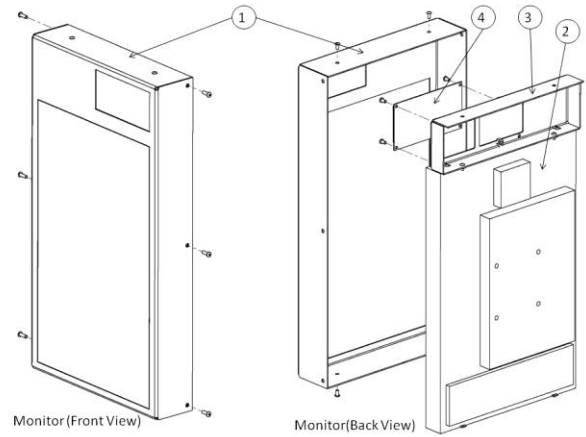

Opening Back Service Panel

Remove back service panel only to service LED lighting, subwoofer and/or to access monitor wiring

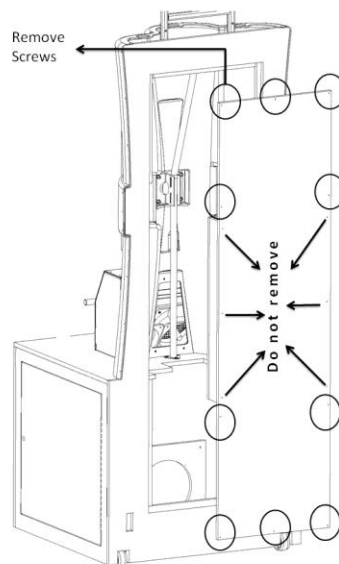

Chapter 6

Control Panel Assembly ADR-KA-3000-00

REF	PART	NUMBER
01	Face Plate	KA-01-3200-00
02	Decal	KA-13-3400-00
03	LED control panel board	KA-04-002-00
04	FAN	KA-04-002-00
-	Control Panel Assy	ADR-KA-3000-00

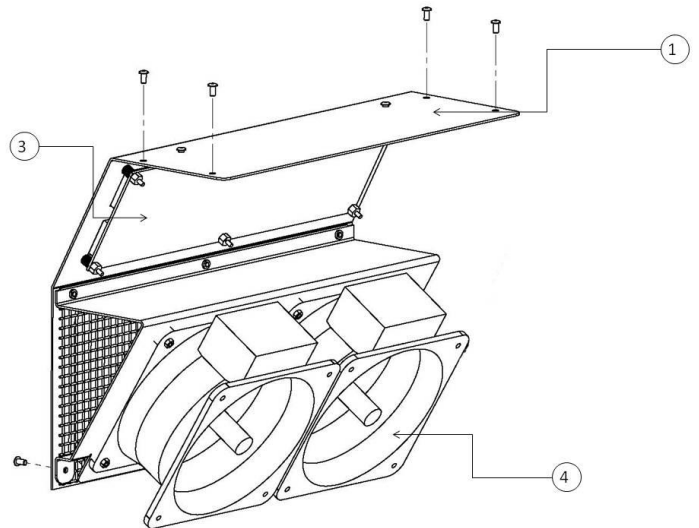
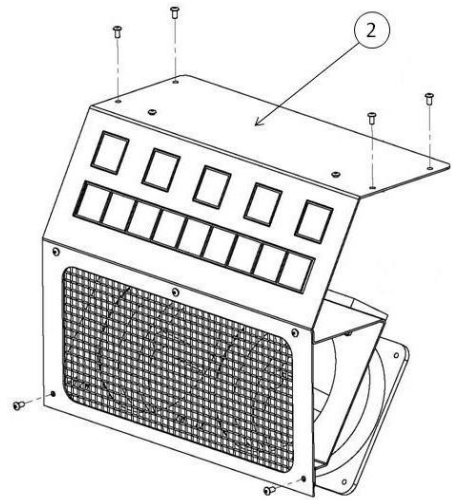

Chapter 6

Electronic Box Assembly ADR-KA-9000-00

REF	PART	NUMBER
01	KABOOM I/O board	KA-04-003-00
02	Amplifier 2.1	KA-04-004-00
03	Transformer XFRMR 36V	ADR-05-004-00
04	Power supply 5V/12V	HAPP 80-0210-00
-	Electronic box assy	ADR-KA-9000-00

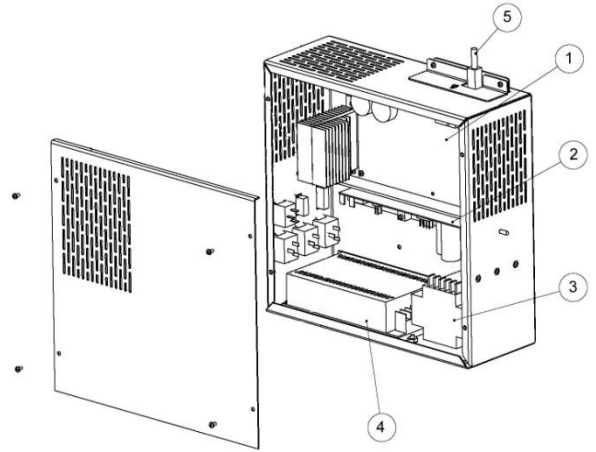

Chapter 7

General Power Distribution Diagram

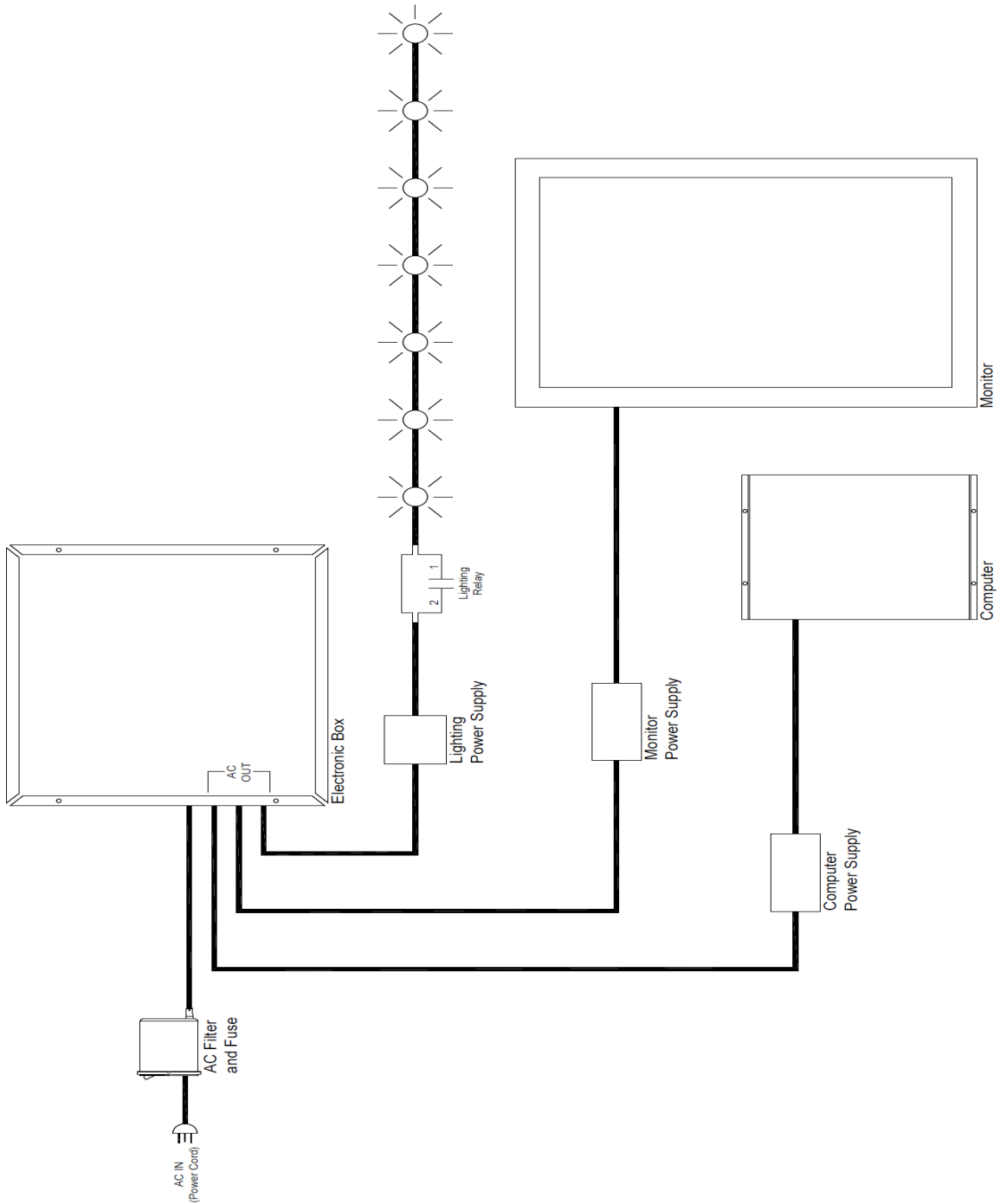

Chapter 7

Electronic Box Power Distribution Diagram

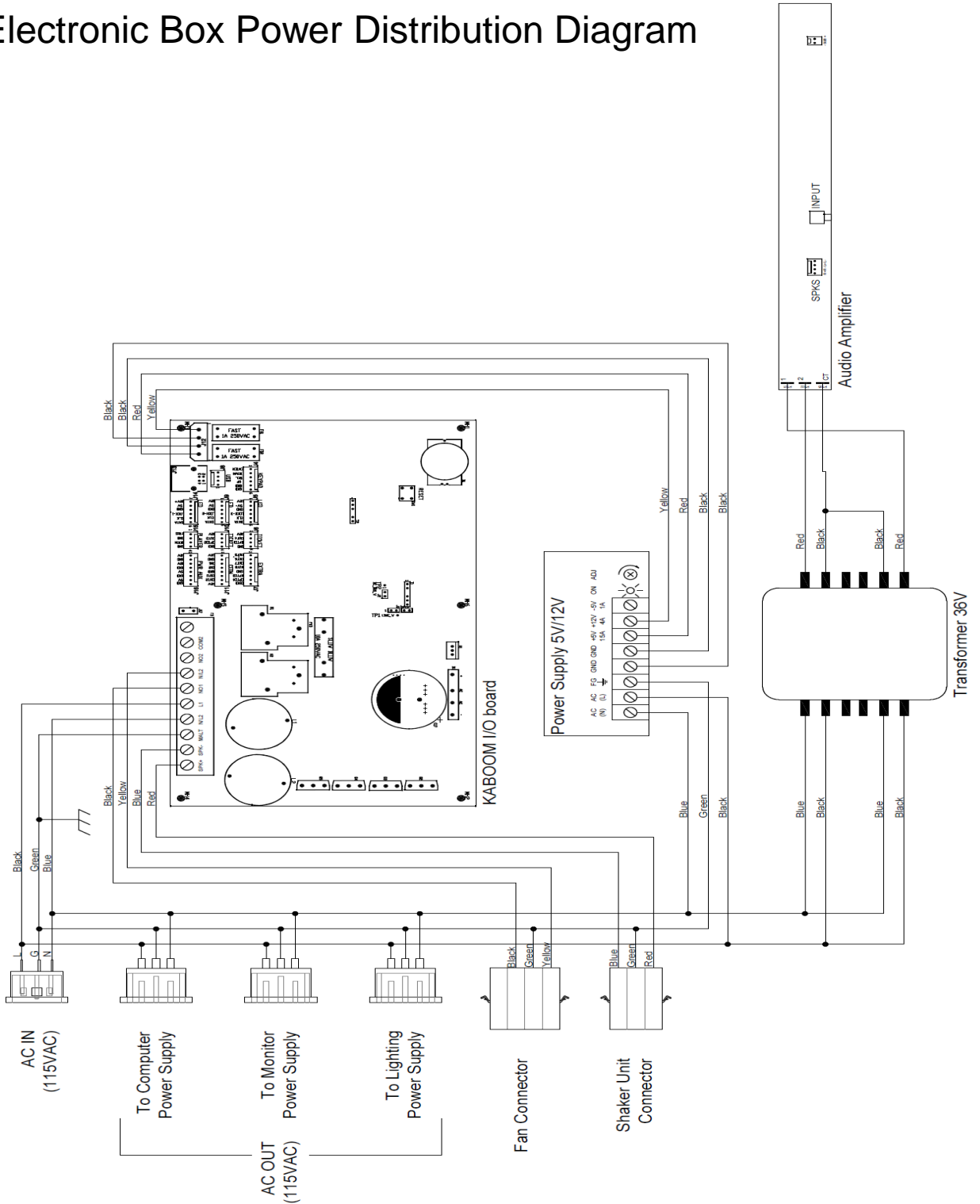

Chapter 7

Simplified Wiring Diagram

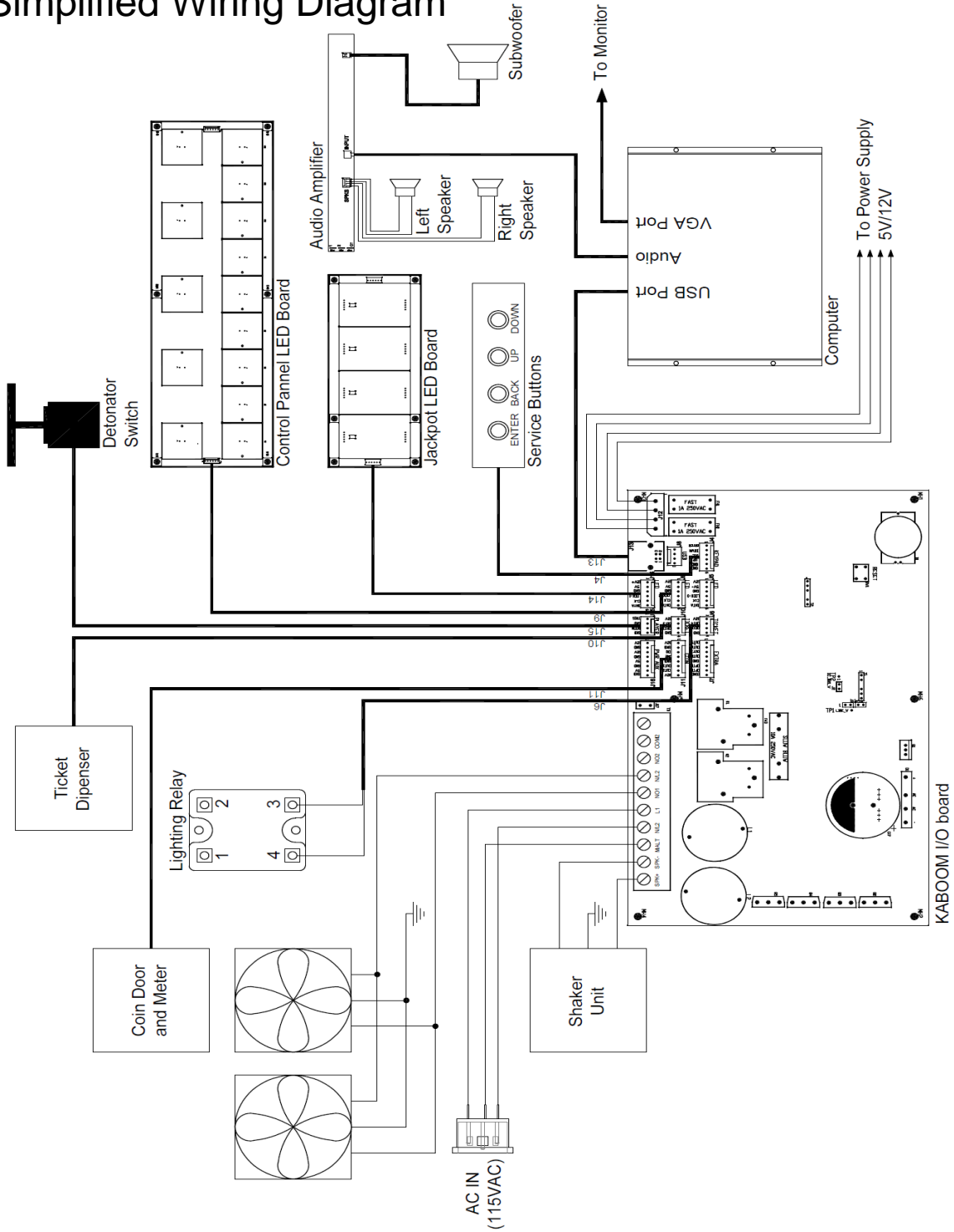

Chapter 7

Detailed Wiring Diagram

