



MANUAL

BROMLEY INCORPORATED

6 Bridlewood Road

Northbrook, IL 60062

(708)509-0240 *Fax (708)509-0242

SERVICE

(708)427-0639 *Fax (708)427-9471

Copyright 1995 Bromley, Incorporated.
All Rights Reserved. Patent Applied For.

5757
+ Lev



Welcome !

Please take a moment to read the following before turning on your new "Colorama" game. Your game has been carefully checked at the factory before shipping.

After removing the game from its carton, please make sure that the game has been leveled per instructions found in this manual. Leg levelers have been provided to assist you in this matter.

Plug the power cord into an AC outlet and turn on the main power switch located on the rear of the cabinet. The fluorescent light behind marquee glass and playfield lights will fire up.

Check the "Game Adjustments" section to be sure the dip switches are set properly.

Load the game with tickets and your new "Colorama" is ready for play!

Dear Customer...

"Colorama" is being sent out at a factory setting of maximum 125 tickets per play. Although this setting may appear to be high. I suggest you keep it at this setting for a few weeks and find out what your ticket average, per coin ends up being. More and more operators are realizing large cash box earnings by simply giving away more tickets.

Included with your game are three ticket value cards, indicating different pay out values. To replace ticket value art remove (6) six tamper proof screws, insert new ticket value card (at all player positions), and replace screws. Refer to dip switch settings to adjust to new values selected. Reset dip switch - then press reset button or turn on/off switch.

I'm sure you will enjoy the earnings for years to come.

Best Regards,

Lauran Bromley, President
Bromley, Incorporated



Player Instructions

Players insert coins to get credit , (99 credits max.) and then can choose any or all colors by pressing the matching colored buttons. The "PRESS BUTTON WHEN LIT" light indicates when and for how long players can choose colors. The drum of colored sections then begins to spin the ball for a specified length of time. The drum then stops and the ball slowly comes to rest at one of the colorama sections. The top-hat then flashes the winning color and tickets are awarded the winners based on the ticket value associated with that color. All players having picked the winning color are awarded tickets.

There is also a dip switch setting to pay out a mercy ticket if no players win. This setting is adjustable, SEE DIP-SW. SETTINGS LIST.

General Information

When you open the far left coin door you will have access to the test switch and meters. Two meters are provided. One is for tickets, the other is for coins.

The volume control is located on the logic P.C. Bd., just below the silver heat sink. The dip switches are also located on this P.C. Bd.

The green led should be flashing, the red and yellow should be dimly lit. If you do not have this condition with power applied to the P.C., then there is a major malfunction on the P.C. The board must be returned for repair to our service department.

To replace the fluorescent lamp or the incandescent bulbs in the back box, remove the screws on the top channel. **CAUTION ! This is a two man operation.** Remove the channel and display glass, put aside in a safe place. You now have access to change the lamps and starter.

Leveling Information

After removing the game from its carton, position the game where it will be operated. The game should be perfectly level across its major axis. This is important to give confidence to both player and operator, that the roll of the ball does not favor any side. This will also allow the drum to rotate true and increase bearing life. Game must be off its wheels to prevent any movement of game during game play.

Color Rama
Version 1.3

DIPSWITCH SETTINGS BANK A

| Ticket Settings | | | | | Switch | 41 | 42 |
|-----------------|-------|------|--------|-------|--------|-----|-----|
| Red | Green | Blue | Yellow | White | | | |
| 25 | 25 | 100 | 150 | 250 | | ON | ON |
| 25 | 25 | 50 | 75 | 125 | | OFF | ON |
| 15 | 15 | 25 | 40 | 75 | | ON | OFF |
| 7 | 7 | 15 | 20 | 40 | | OFF | OFF |

| Mercy Ticket Settings | | Switch | 45 | 46 |
|-----------------------|------|--------|-----|-----|
| | None | | OFF | OFF |
| | 1 | | ON | OFF |
| | 2 | | OFF | ON |
| | 4 | | ON | ON |

| Skill Stop Feature | | Switch | 47 |
|--------------------|------------------------|--------|-----|
| | Normal | | OFF |
| | Skill stop button used | | ON |

| Ticket Dispenser | | Switch | 48 |
|------------------|---------------------------|--------|-----|
| | Normal | | OFF |
| | Ticket dispenser not used | | ON |

INPUT PORT ASSIGNMENTS

OUTPUT PORT ASSIGNMENTS

Port 38h

(CPU J1-10) Bit 0 = Red Crown Switch
 (CPU J1-9) Bit 1 = Green Crown Switch
 (CPU J1-8) Bit 2 = Blue Crown Switch
 (CPU J1-7) Bit 3 = Yellow Crown Switch
 (CPU J1-6) Bit 4 = White Crown Switch
 (CPU J1-4) Bit 5 = Tilt Switch
 (CPU J1-3) Bit 6 = Test Switch
 (CPU J1-1) Bit 7 = Audit Switch

Port 30h

(CPU J2-1) Bit 0 = Switch Return 0
 (CPU J2-2) Bit 1 = Switch Return 1
 (CPU J2-4) Bit 2 = Switch Return 2
 (CPU J2-5) Bit 3 = Switch Return 3
 (CPU J2-6) Bit 4 = Switch Return 4
 (CPU J2-7) Bit 5 = Switch Return 5
 (CPU J2-8) Bit 6 =
 (CPU J2-9) Bit 7 =

Port 69h

(I/O J4-1) Bit 0 = Player 1 Ticket Notch
 (I/O J4-2) Bit 1 = Player 2 Ticket Notch
 (I/O J4-3) Bit 2 = Player 3 Ticket Notch
 (I/O J4-5) Bit 3 = Player 4 Ticket Notch
 (I/O J4-6) Bit 4 = Player 1 Ticket Clear
 (I/O J4-7) Bit 5 = Player 2 Ticket Clear
 (I/O J4-8) Bit 6 = Player 3 Ticket Clear
 (I/O J4-9) Bit 7 = Player 4 Ticket Clear

Port 6ah

(I/O J5-1) Bit 0 = Player 1 Skill Stop Switch
 (I/O J5-2) Bit 1 = Player 2 Skill Stop Switch
 (I/O J5-4) Bit 2 = Player 3 Skill Stop Switch
 (I/O J5-5) Bit 3 = Player 4 Skill Stop Switch
 (I/O J5-6) Bit 4 =
 (I/O J5-7) Bit 5 =
 (I/O J5-8) Bit 6 =
 (I/O J5-9) Bit 7 =

Port 6bh

(I/O J6-4) Bit 0 =
 (I/O J6-3) Bit 1 =
 (I/O J6-2) Bit 2 =
 (I/O J6-1) Bit 3 =
 (I/O J6-5) Bit 4 =
 (I/O J6-6) Bit 5 =
 (I/O J6-8) Bit 6 =
 (I/O J6-9) Bit 7 =

Port 18h

(CPU J5-3) Bit 0 =
 (CPU J5-5) Bit 1 = Red L.E.D.
 (CPU J3-8) & (J5-7) Bit 2 = Yellow L.E.D.
 (CPU J3-7) Bit 3 = Green L.E.D.
 Bit 4 = Coin Meter
 Bit 5 = Ticket Meter
 Bit 6 = Ticket Dispenser Player 2
 Bit 7 = Ticket Dispenser Player 1

Port 60h

(I/O J11-4) Bit 0 =
 (I/O J11-2) Bit 1 =
 (I/O J11-1) Bit 2 = Ticket Dispenser Player 3
 (I/O J2-4) Bit 3 = Ticket Dispenser Player 4
 (I/O J2-5) Bit 4 =
 (I/O J2-5) Bit 5 =
 (I/O J12-3) Bit 6 =
 (I/O J12-1) Bit 7 = AC Driver Drum Motor

Port 61h

(I/O J8-1) Bit 0 = Lamp Data 0
 (I/O J8-3) Bit 1 = Lamp Data 1
 (I/O J8-4) Bit 2 = Lamp Data 2
 (I/O J8-5) Bit 3 = Lamp Data 3
 (I/O J8-6) Bit 4 = Lamp Data 4
 (I/O J8-7) Bit 5 = Lamp Data 5
 (I/O J8-8) Bit 6 = Lamp Data 6
 (I/O J8-9) Bit 7 = Lamp Voltage To Crown Lamps

Port 62h

(I/O J1-7) Bit 0 = Player 1 Hopper Enable (Hopper Version)
 (I/O J1-2) Bit 1 = Player 2 Hopper Enable (Hopper Version)
 (I/O J1-9) Bit 2 = Player 3 Hopper Enable (Hopper Version)
 (I/O J1-4) Bit 3 = Player 4 Hopper Enable (Hopper Version)
 (I/O J1-1) Bit 4 = Lamp Strobe Player 1
 (I/O J1-6) Bit 5 = Lamp Strobe Player 2
 (I/O J1-3) Bit 6 = Lamp Strobe Player 3
 (I/O J1-5) Bit 7 = Lamp Strobe Player 4

Port 63h

(I/O J10-8) Bit 0 = Display Data To Players 1, 2, 3, 4
 (I/O J10-7) Bit 1 = Display Clk To Players 1, 2, 3, 4
 (I/O J10-9) Bit 2 =
 (I/O J10-6) Bit 3 =
 (I/O J10-1) Bit 4 = Player 1 Display Latch Enable
 (I/O J10-5) Bit 5 = Player 2 Display Latch Enable
 (I/O J10-3) Bit 6 = Player 3 Display Latch Enable
 (I/O J10-2) Bit 7 = Player 4 Display Latch Enable

Port 68h

(I/O J9-1) Bit 0 = Upper Red Lamp (To Ac Driver Bd 1)
 (I/O J9-4) Bit 1 = Upper Green Lamp (To Ac Driver Bd 1)
 (I/O J9-6) Bit 2 = Upper Blue Lamp (To Ac Driver Bd 1)
 (I/O J9-9) Bit 3 = Upper Yellow Lamp (To Ac Driver Bd 1)
 (I/O J9-8) Bit 4 = Upper White Lamp (To Ac Driver Bd 2)
 (I/O J9-7) Bit 5 = Rope Lamp Ch 1 (To Ac Driver Bd 2)
 (I/O J9-5) Bit 6 = Rope Lamp Ch 2 (To Ac Driver Bd 2)
 (I/O J9-2) Bit 7 = Rope Lamp Ch 3 (To Ac Driver Bd 2)

LAMP ASSIGNMENTS

player 1 red lamp = strobe 0 / data 0
player 1 green lamp = strobe 0 / data 1
player 1 blue lamp = strobe 0 / data 2
player 1 yellow lamp = strobe 0 / data 3
player 1 white lamp = strobe 0 / data 4
player 1 selection lamp = strobe 0 / data 5
player 1 skill stop lamp = strobe 0 / data 6
= strobe 0 / data 7

player 2 red lamp = strobe 1 / data 0
player 2 green lamp = strobe 1 / data 1
player 2 blue lamp = strobe 1 / data 2
player 2 yellow lamp = strobe 1 / data 3
player 2 white lamp = strobe 1 / data 4
player 2 selection lamp = strobe 1 / data 5
player 2 skill stop lamp = strobe 1 / data 6
= strobe 1 / data 7

player 3 red lamp = strobe 2 / data 0
player 3 green lamp = strobe 2 / data 1
player 3 blue lamp = strobe 2 / data 2
player 3 yellow lamp = strobe 2 / data 3
player 3 white lamp = strobe 2 / data 4
player 3 selection lamp = strobe 2 / data 5
player 3 skill stop lamp = strobe 2 / data 6
= strobe 2 / data 7

player 4 red lamp = strobe 3 / data 0
player 4 green lamp = strobe 3 / data 1
player 4 blue lamp = strobe 3 / data 2
player 4 yellow lamp = strobe 3 / data 3
player 4 white lamp = strobe 3 / data 4
player 4 selection lamp = strobe 3 / data 5
player 4 skill stop lamp = strobe 3 / data 6
= strobe 3 / data 7

LAMP ASSIGNMENTS

player 1 red lamp = strobe 0 / data 0
player 1 green lamp = strobe 0 / data 1
player 1 blue lamp = strobe 0 / data 2
player 1 yellow lamp = strobe 0 / data 3
player 1 white lamp = strobe 0 / data 4
player 1 selection lamp = strobe 0 / data 5
player 1 skill stop lamp = strobe 0 / data 6
= strobe 0 / data 7

player 2 red lamp = strobe 1 / data 0
player 2 green lamp = strobe 1 / data 1
player 2 blue lamp = strobe 1 / data 2
player 2 yellow lamp = strobe 1 / data 3
player 2 white lamp = strobe 1 / data 4
player 2 selection lamp = strobe 1 / data 5
player 2 skill stop lamp = strobe 1 / data 6
= strobe 1 / data 7

player 3 red lamp = strobe 2 / data 0
player 3 green lamp = strobe 2 / data 1
player 3 blue lamp = strobe 2 / data 2
player 3 yellow lamp = strobe 2 / data 3
player 3 white lamp = strobe 2 / data 4
player 3 selection lamp = strobe 2 / data 5
player 3 skill stop lamp = strobe 2 / data 6
= strobe 2 / data 7

player 4 red lamp = strobe 3 / data 0
player 4 green lamp = strobe 3 / data 1
player 4 blue lamp = strobe 3 / data 2
player 4 yellow lamp = strobe 3 / data 3
player 4 white lamp = strobe 3 / data 4
player 4 selection lamp = strobe 3 / data 5
player 4 skill stop lamp = strobe 3 / data 6
= strobe 3 / data 7

Test 6 = SWITCH TEST

Displays shorted switch number when switch is closed

- 01 = player 1 red switch
- 02 = player 1 green switch
- 03 = player 1 blue switch
- 04 = player 1 yellow switch
- 05 = player 1 white switch
- 06 = player 1 coin switch
- 07 = player 2 red switch
- 08 = player 2 green switch
- 09 = player 2 blue switch
- 10 = player 2 yellow switch
- 11 = player 2 white switch
- 12 = player 2 coin switch
- 13 = player 3 red switch
- 14 = player 3 green switch
- 15 = player 3 blue switch
- 16 = player 3 yellow switch
- 17 = player 3 white switch
- 18 = player 3 coin switch
- 19 = player 4 red switch
- 20 = player 4 green switch
- 21 = player 4 blue switch
- 22 = player 4 yellow switch
- 23 = player 4 white switch
- 24 = player 4 coin switch
- 25 = player 1 ticket switch
- 26 = player 2 ticket switch
- 27 = player 3 ticket switch
- 28 = player 4 ticket switch
- 29 = player 1 ticket clear switch
- 30 = player 2 ticket clear switch
- 31 = player 3 ticket clear switch
- 32 = player 4 ticket clear switch
- 33 = drum red switch
- 34 = drum green switch
- 35 = drum blue switch
- 36 = drum yellow switch
- 37 = drum white switch
- 38 = audit switch
- 39 = tilt switch
- 40 = player 1 skill stop switch
- 41 = player 2 skill stop switch
- 42 = player 3 skill stop switch
- 43 = player 4 skill stop switch

Test 7 = LAMP TEST

Audit button = advance to next lamp output

The Main Display Will Show-

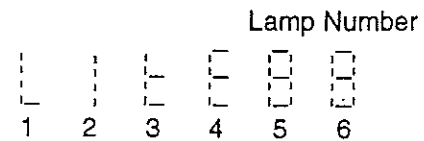

- 01 = player 1 red lamp
- 02 = player 1 green lamp
- 03 = player 1 blue lamp
- 04 = player 1 yellow lamp
- 05 = player 1 white lamp
- 06 = player 1 ready lamp
- 07 = player 1 skill stop lamp
- 08 = player 2 red lamp
- 09 = player 2 green lamp
- 10 = player 2 blue lamp
- 11 = player 2 yellow lamp
- 12 = player 2 white lamp
- 13 = player 2 ready lamp
- 14 = player 2 skill stop lamp
- 15 = player 3 red lamp
- 16 = player 3 green lamp
- 17 = player 3 blue lamp
- 18 = player 3 yellow lamp
- 19 = player 3 white lamp
- 20 = player 3 ready lamp
- 21 = player 3 skill stop lamp
- 22 = player 4 red lamp
- 23 = player 4 green lamp
- 24 = player 4 blue lamp
- 25 = player 4 yellow lamp
- 26 = player 4 white lamp
- 27 = player 4 ready lamp
- 28 = player 4 skill stop lamp
- 29 = upper red billboard lamp
- 30 = upper green billboard lamp
- 31 = upper blue billboard lamp
- 32 = upper yellow billboard lamp
- 33 = upper white billboard lamp
- 34 = rope lamp channel 1
- 35 = rope lamp channel 2
- 36 = rope lamp channel 3

Test 8 = OUTPUT TEST

Audit switch = to start test and to advance to next output
The Display Will Show-

Output Number

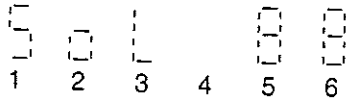

- 01 = coin meter
- 02 = ticket meter
- 03 = drum meter

Test 9 = PLAYER 1 TICKET DISPENSER TEST

Audit switch = used to dispense 1 ticket
When dispenser is idle the display will show-

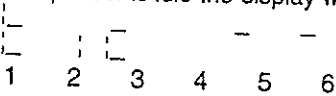

When trying to dispense a ticket the display will show-

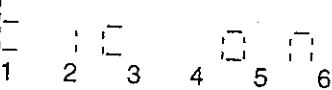

If ticket dispenser errors the display will show-

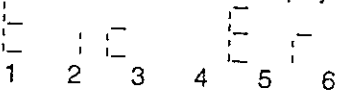

Test 10 = PLAYER 2 TICKET DISPENSER TEST

Audit switch = used to dispense 1 ticket
When dispenser is idle the display will show-

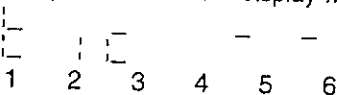

When trying to dispense a ticket the display will show-

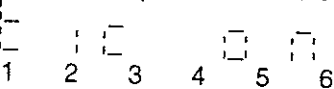

If ticket dispenser errors the display will show-

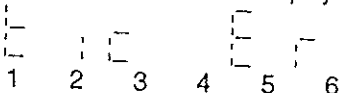

Test 11 = PLAYER 3 TICKET DISPENSER TEST

Audit switch = used to dispense 1 ticket
When dispenser is idle the display will show-

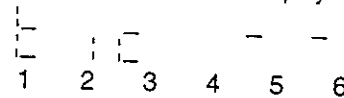

When trying to dispense a ticket the display will show-

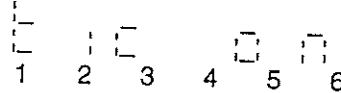

If ticket dispenser errors the display will show-

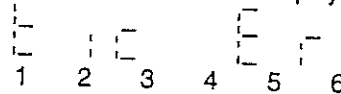

Test 12 = PLAYER 4 TICKET DISPENSER TEST

Service switch = used to dispense 1 ticket
When dispenser is idle the display will show-

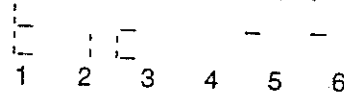

When trying to dispense a ticket the display will show-

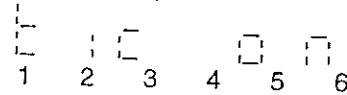

If ticket dispenser errors the display will show-

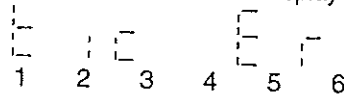

Test 13 = SOUND TEST

Audit switch = advances and plays next sound

The Display Will Show-

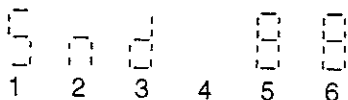

- sound 00 - spinning wheel music
- sound 01 - spinning wheel stop motor
- sound 02 - new drum tune
- sound 03 - all sounds off
- sound 04 - alarm...alarm...alarm
- sound 05 - coin in version 1
- sound 06 - coin in version 2
- sound 07 - coin in version 3
- sound 08 - coin in version 4
- sound 09 - coin in version 5
- sound 10 - ball lands in area
- sound 11 - double pop
- sound 12 - pop
- sound 13 - metal rattle
- sound 14 - plink pop
- sound 15 - alarm bell
- sound 16 - pop version 2
- sound 17 - bottle open
- sound 18 - the winning color is white
- sound 19 - the winning color is red
- sound 20 - the winning color is yellow
- sound 21 - the winning color is green
- sound 22 - the winning color is blue
- sound 23 - insert coins and select your color
- sound 24 - lets play color rama
- sound 25 - select your color
- sound 26 - color rama
- sound 27 - blue
- sound 28 - green
- sound 29 - red
- sound 30 - white
- sound 31 - yellow

AUDIT MODE:

TO ENTER AUDIT MODE:
PRESS THE AUDIT SWITCH LOCATED
INSIDE PLAYER 1 FRONT DOOR

Bookkeeping Section -

- Use the audit switch to advance to the next audit function
- Use the test switch to clear count

The Main Display Will Show-

Audit Number

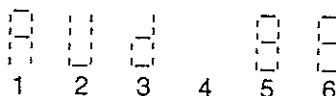

- Audit 01 = Remaining Unused Credits For Player 1
- Audit 02 = Remaining Unused Credits For Player 2
- Audit 03 = Remaining Unused Credits For Player 3
- Audit 04 = Remaining Unused Credits For Player 4
- Audit 05 = Total Coins Inserted
- Audit 06 = Total Tickets Dispensed
- Audit 07 = Average Tickets Dispensed
- Audit 08 = Tickets Remaining Player 1
- Audit 09 = Tickets Remaining Player 2
- Audit 10 = Tickets Remaining Player 3
- Audit 11 = Tickets Remaining Player 4
- Audit 12 = Remaining Counts For Ticket Meter
- Audit 13 = Total Number Of Red Wins
- Audit 14 = Total Number Of Green Wins
- Audit 15 = Total Number Of Blue Wins
- Audit 16 = Total Number Of Yellow Wins
- Audit 17 = Total Number Of White Wins

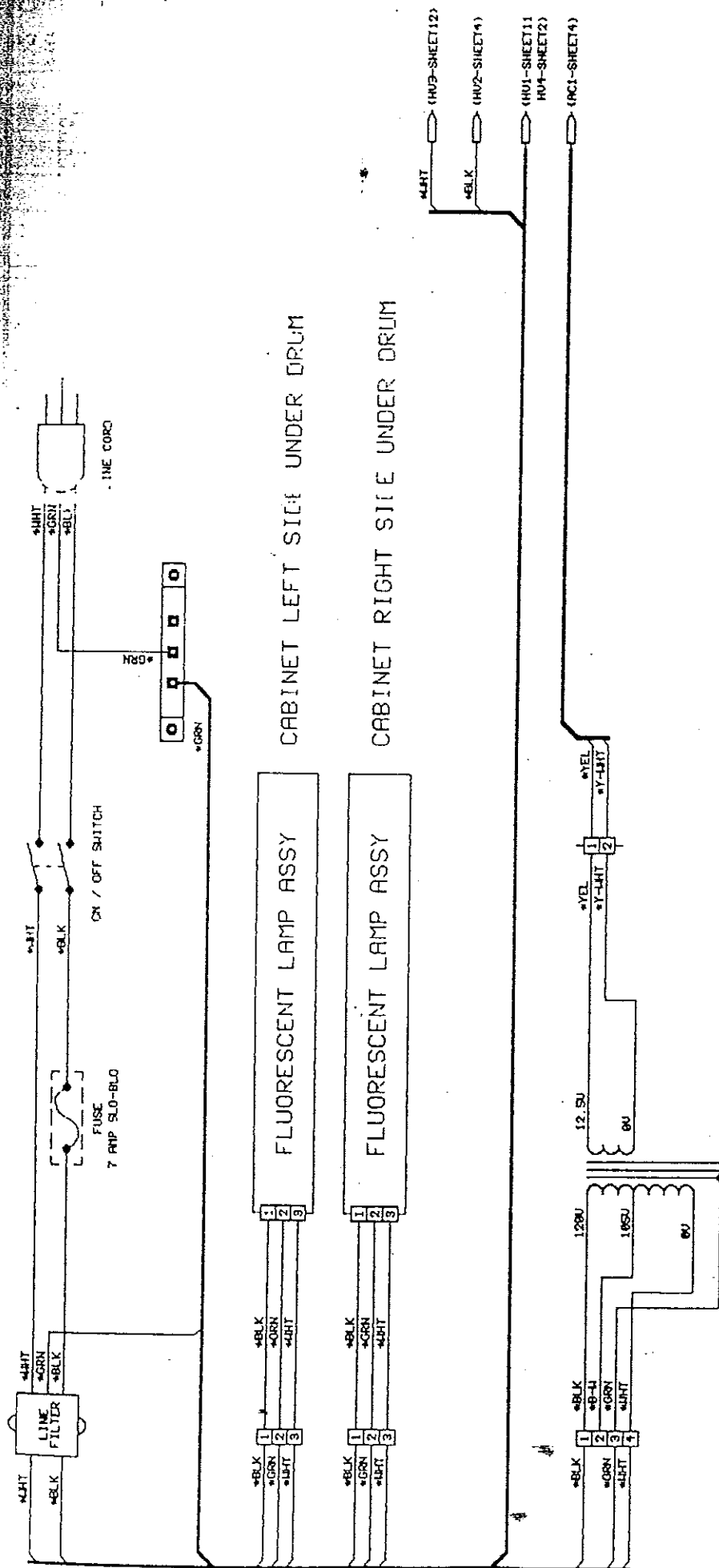

CABINET LEFT SIDE UNDER DRUM
 CABINET RIGHT SIDE UNDER DRUM

TRANSFORMER 437P48

| | |
|----------------------------|----------|
| BROMLEY INC. | |
| TITLE COLOR RAMA | |
| HIGH VOLTAGE WIRING 1 OF 2 | |
| DATE / / | DWG. NO. |
| SHEET 1 OF 12 | |

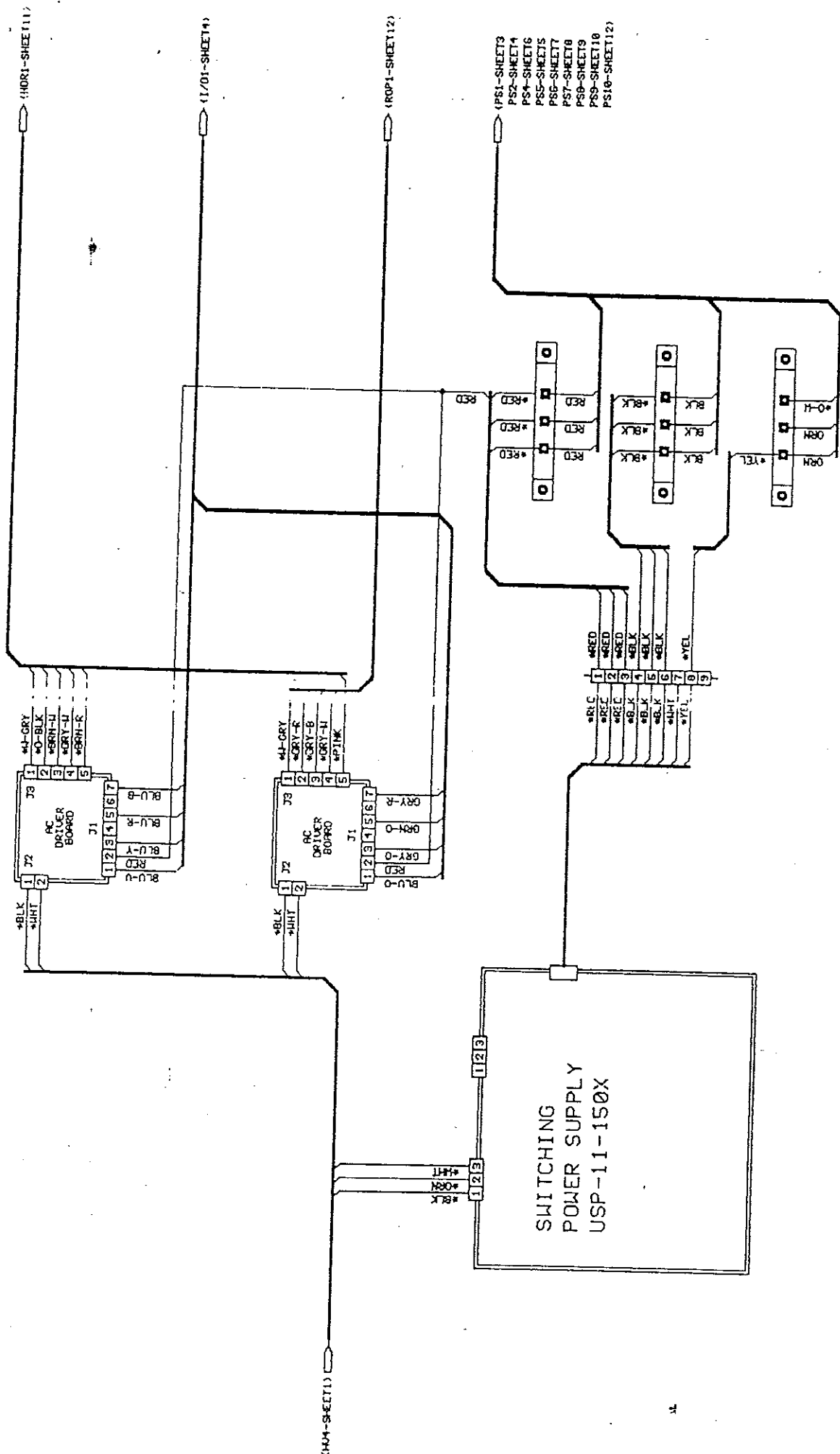

| | |
|----------------------------|----------|
| BROMLEY INC. | |
| TITLE COLOR RAMA | |
| HIGH VOLTAGE WIRING 2 OF 2 | |
| DATE | DWG. NO. |
| | SHEET |
| | 2 OF 10 |

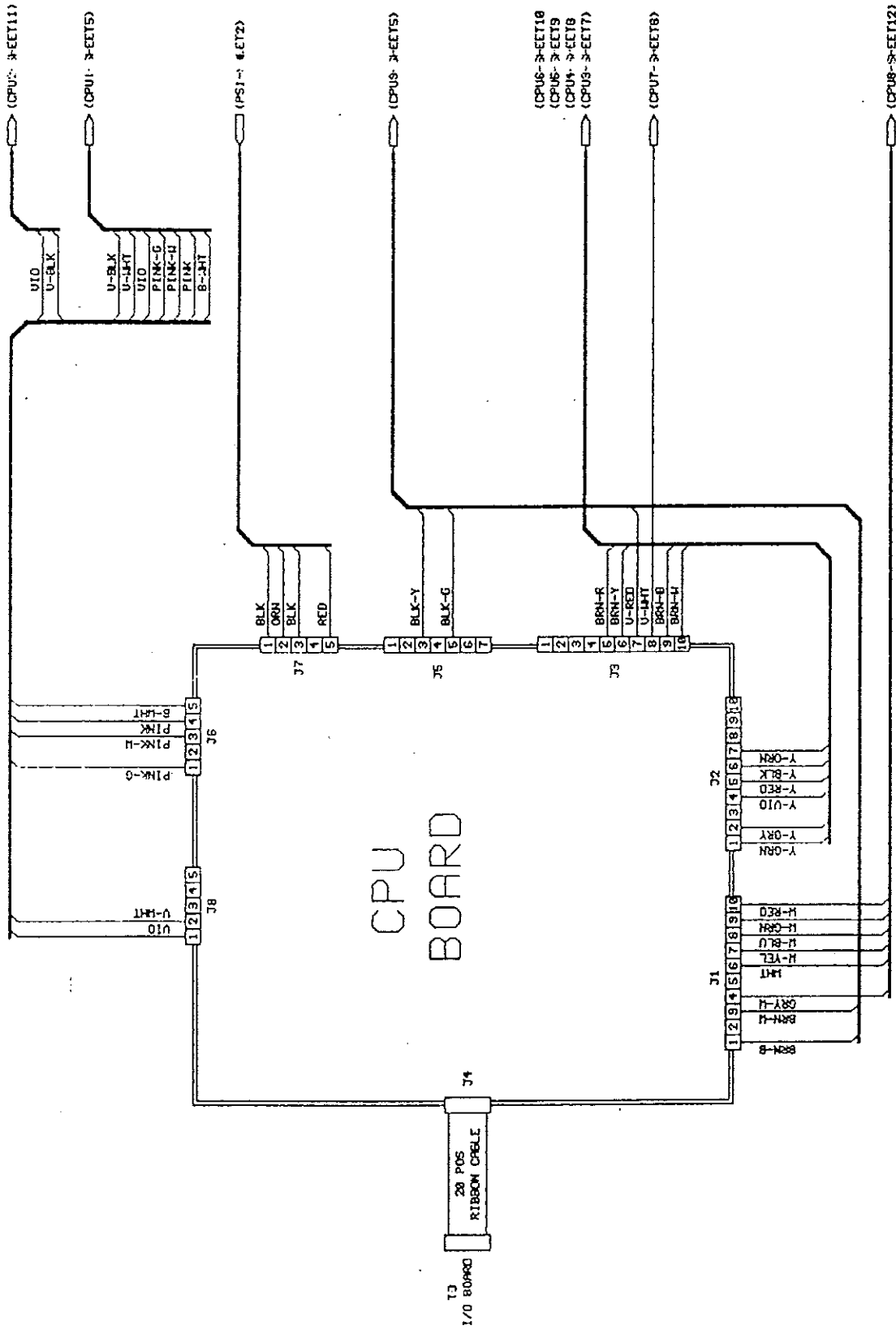

| | |
|---|------------------------------|
| BROMLEY INC. | |
| TITLE COLOF RAMA CABINET WIRING 1 OF 2 | |
| DATE / / | DWG. NO. SHEET 3 OF 12 |

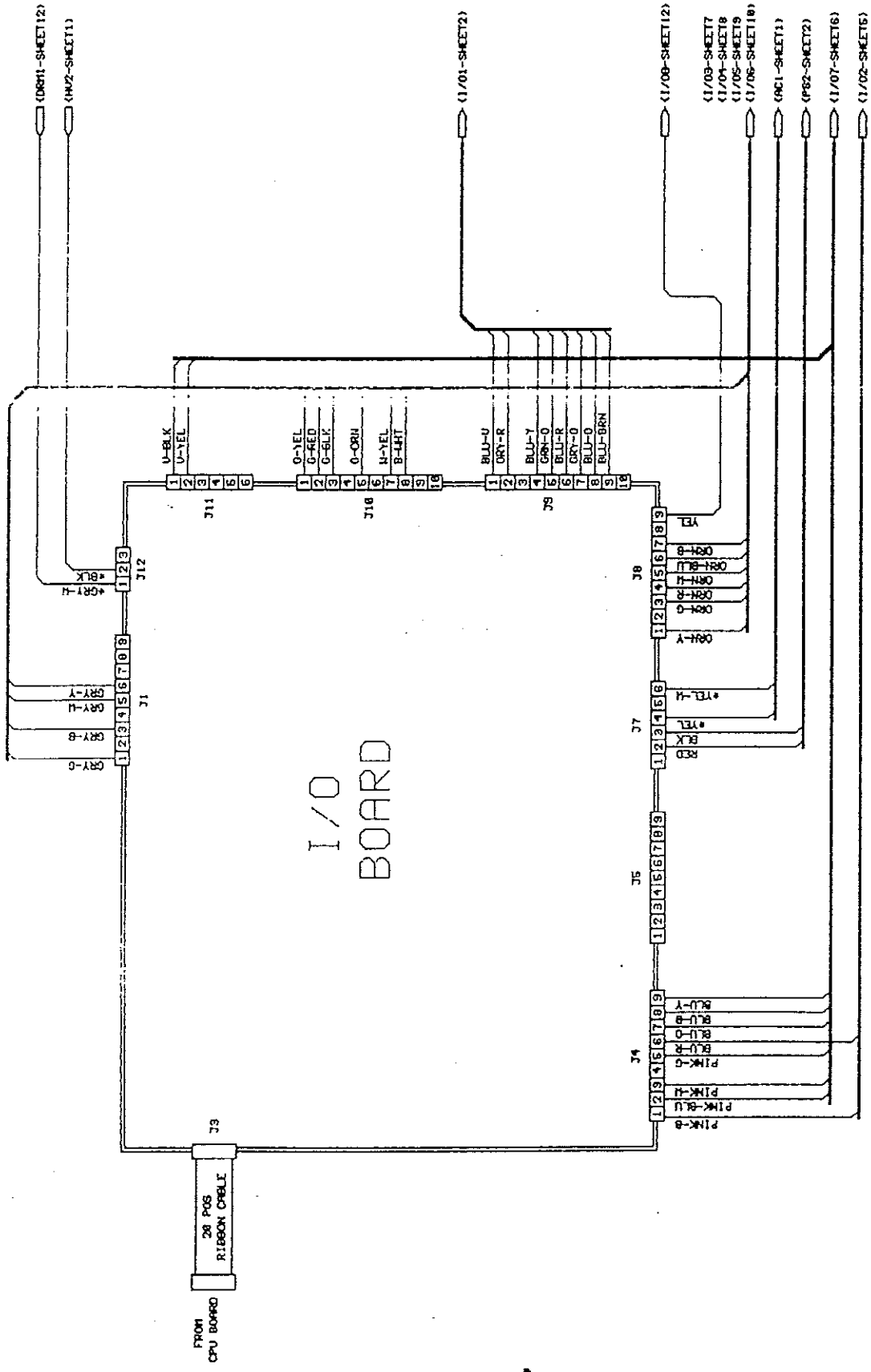

I/O BOARD

| | |
|-----------------------|---------|
| BROMLEY INC. | |
| COLOR RAMA | |
| CABINET WIRING 2 OF 2 | |
| TITLE | SHEET |
| DATE / / | 9 OF 12 |
| DRG. NO. | |

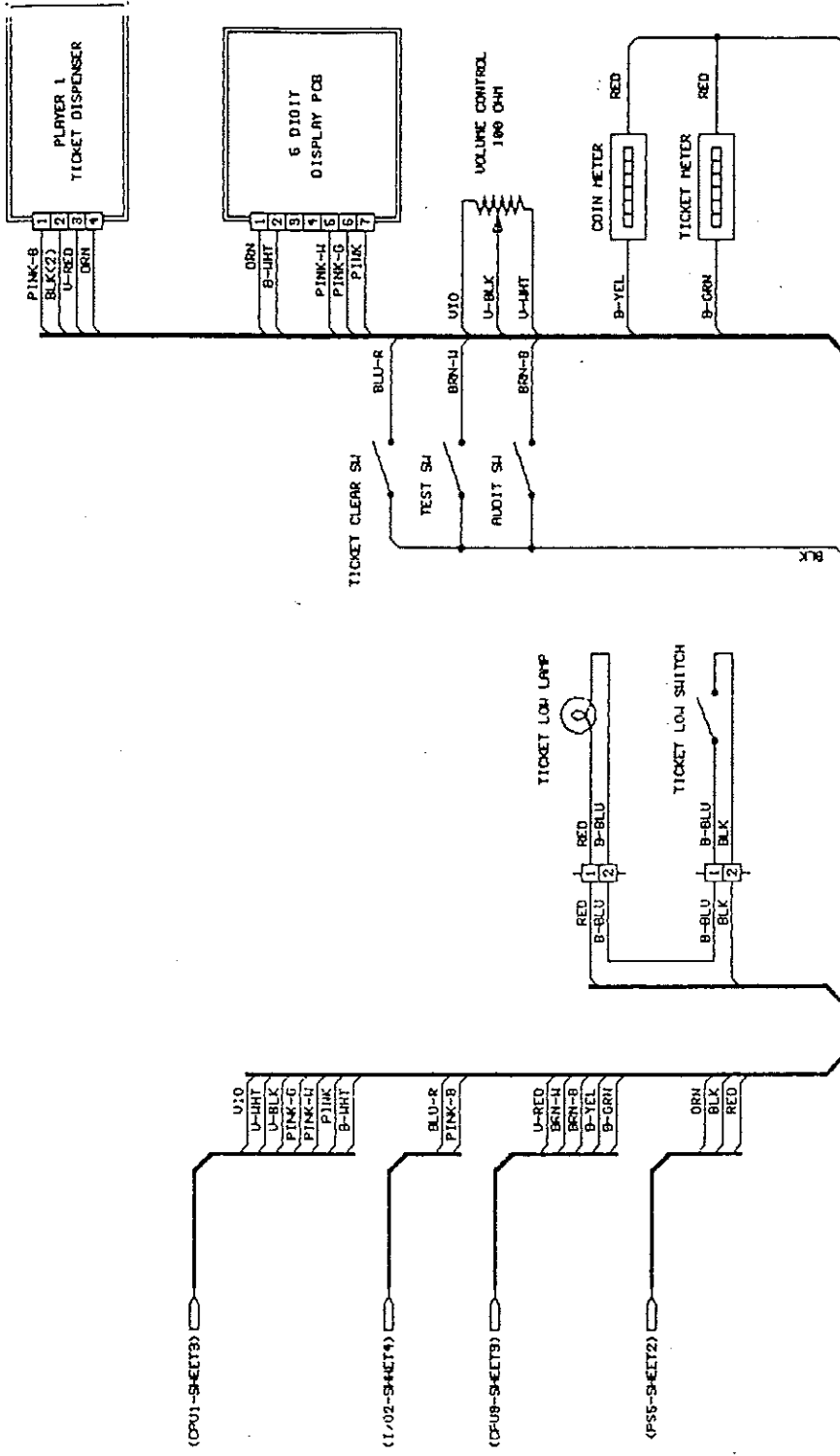

| | |
|----------------------------|----------|
| BROMLEY INC. | |
| TITLE COLOR RAMA | |
| PLAYER 1 TICKET DOOR | |
| DATE / / | DWG. NO. |
| SHEET | 5 OF 12 |

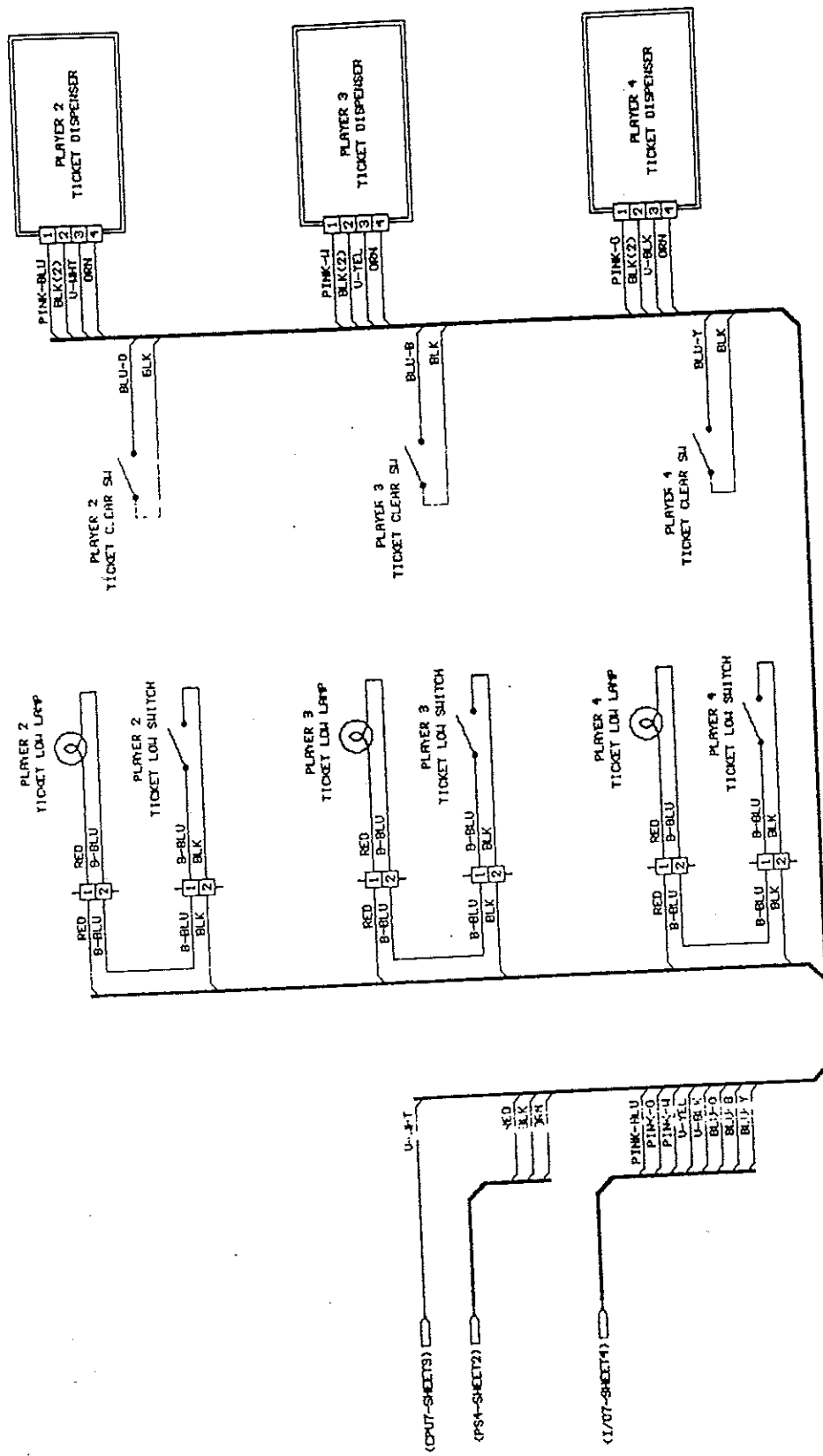

| | |
|----------------------------|---------------|
| BROMLEY INC. | |
| TITLE | COLOR RAMA |
| TICKET DOORS PLAYERS 2,3,4 | |
| DATE / / | SHEET 6 OF 12 |
| NO. NO. | |

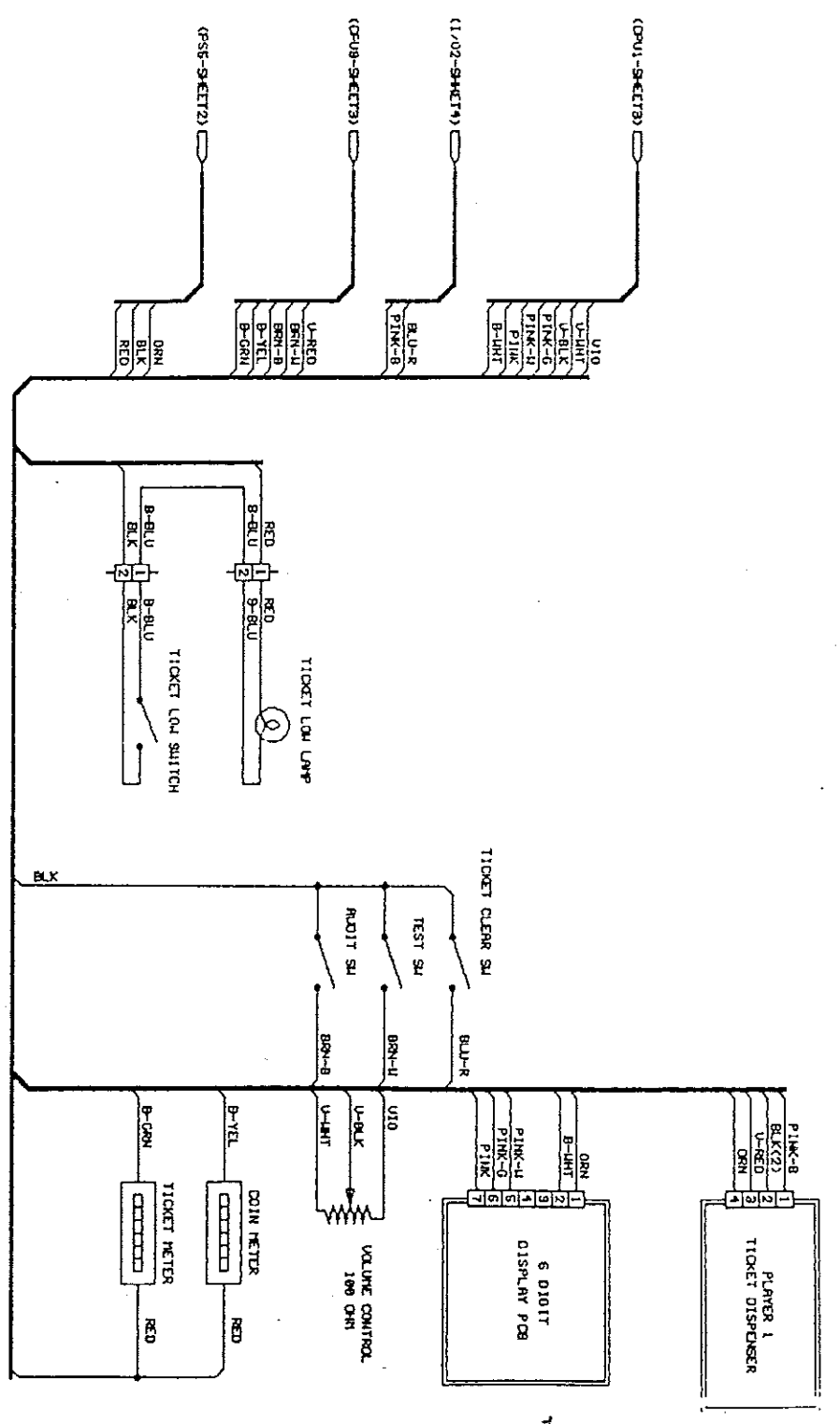

| | | | |
|----------------------|----------|--------------|--|
| TITLE | | BROMLEY INC. | |
| COLOR RAMA | | | |
| PLAYER 1 TICKET DOOR | | | |
| DATE | DWG. NO. | SHEET | |
| / / | | 5 OF 12 | |

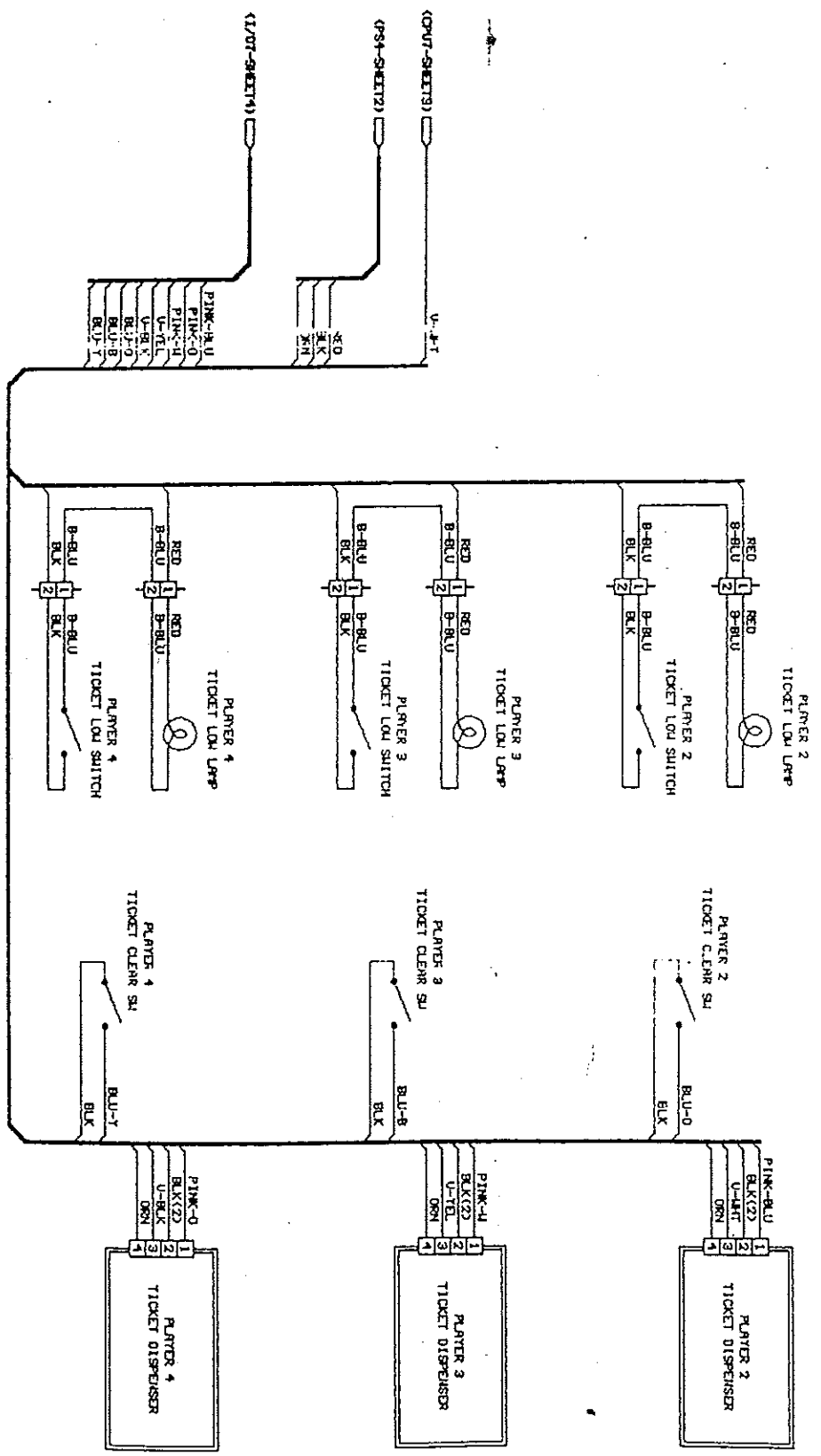

| | | | |
|----------------------------|----------|--------------|-------|
| TITLE | | BROMLEY INC. | |
| COLOR RAMPA | | | |
| TICKET DOORS PLAYERS 2,3,4 | | | |
| DATE | QUD. NO. | SHEET | |
| / / | | 6 | OF 12 |

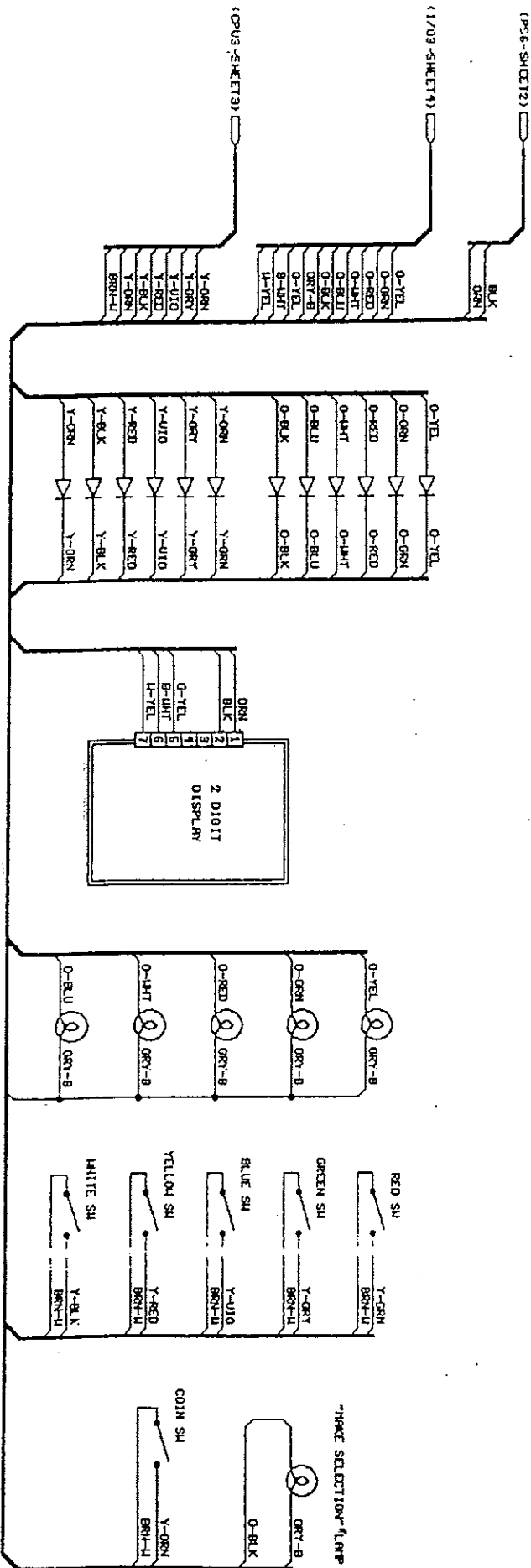

| | | |
|------------------------|----------|---------|
| BROMLEY INC. | | |
| TITLE | | |
| COLOR RAMP | | |
| PLAYER 1 CONTROL PANEL | | |
| DATE | DWG. NO. | SHEET |
| / / | | 7 OF 12 |

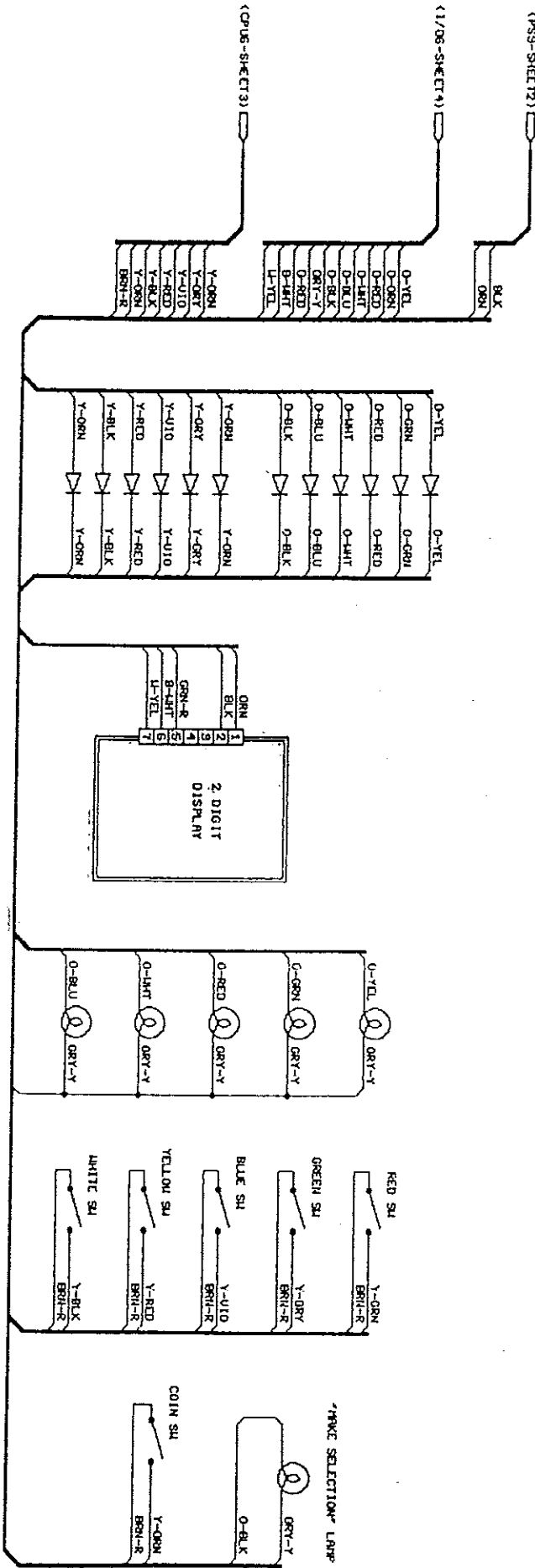

| | | | |
|------------|-----|------------------------|----------|
| TITLE | | BROMLEY INC. | |
| COLOR RAMP | | PLAYER 4 CONTROL PANEL | |
| DATE | NO. | SHEET | 10 OF 12 |

MINING COLOR LAMPS

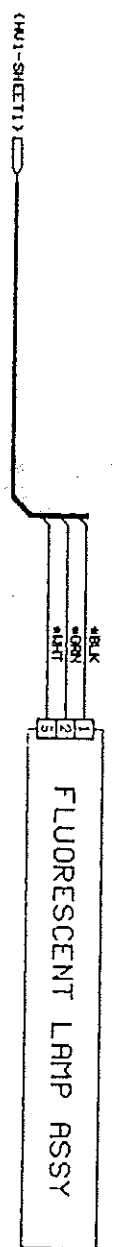
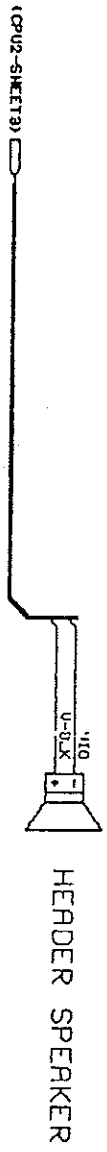
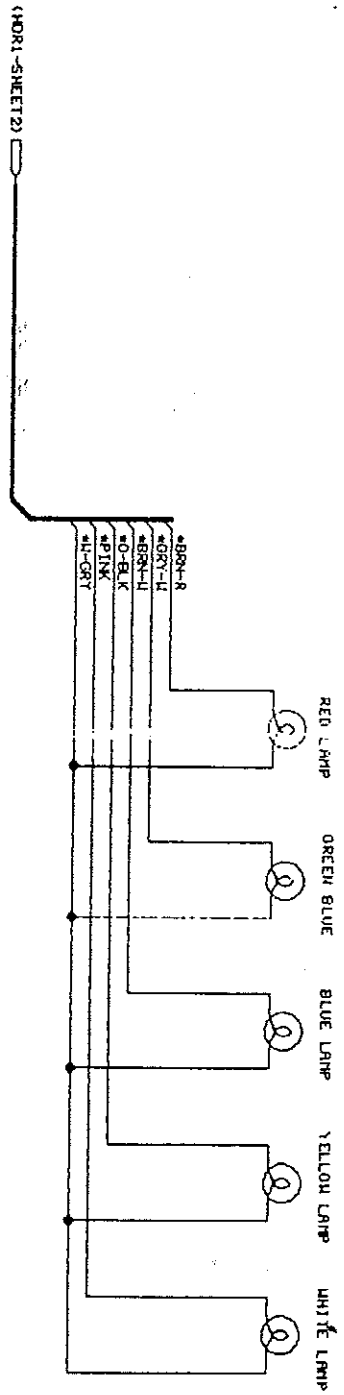

| | | | |
|---------------|--|----------|--|
| BROMLEY INC | | TITLE | |
| COLOR RAMM | | DATE / / | |
| HEADER WIRING | | DWO. NO. | |
| 11 OF 12 | | SHEET | |

MINNING COLOR LAMPS

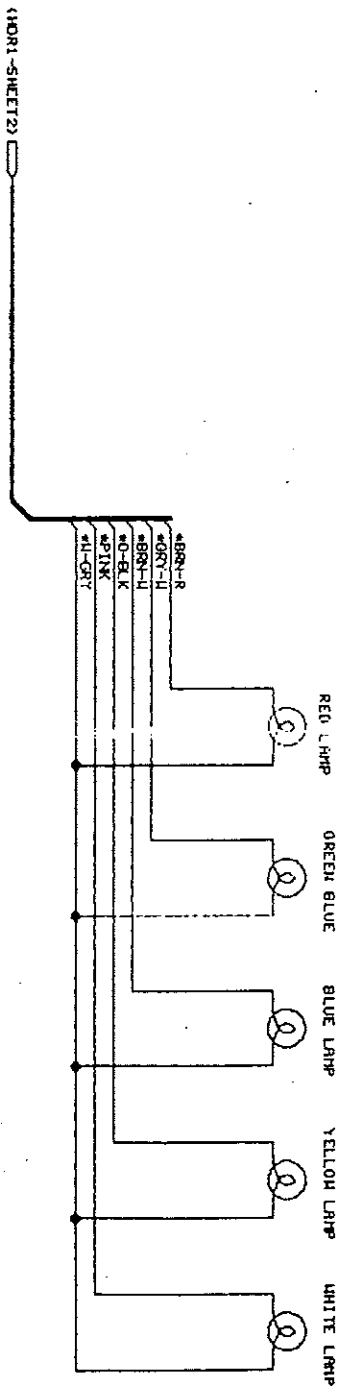

| | |
|---------------|----------|
| BROMLEY INC | |
| TITLE | |
| COLOR RAMP | |
| HEADER WIRING | |
| DATE | DMG. NO. |
| / / | |
| SHEET | 11 OF 12 |

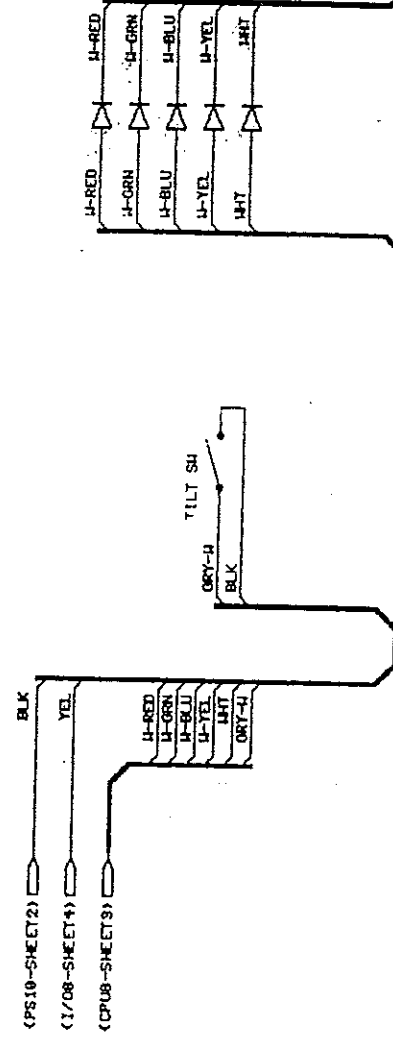
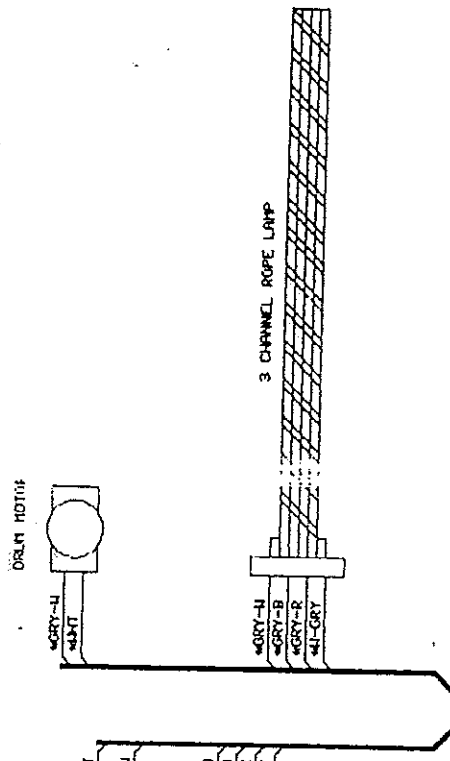
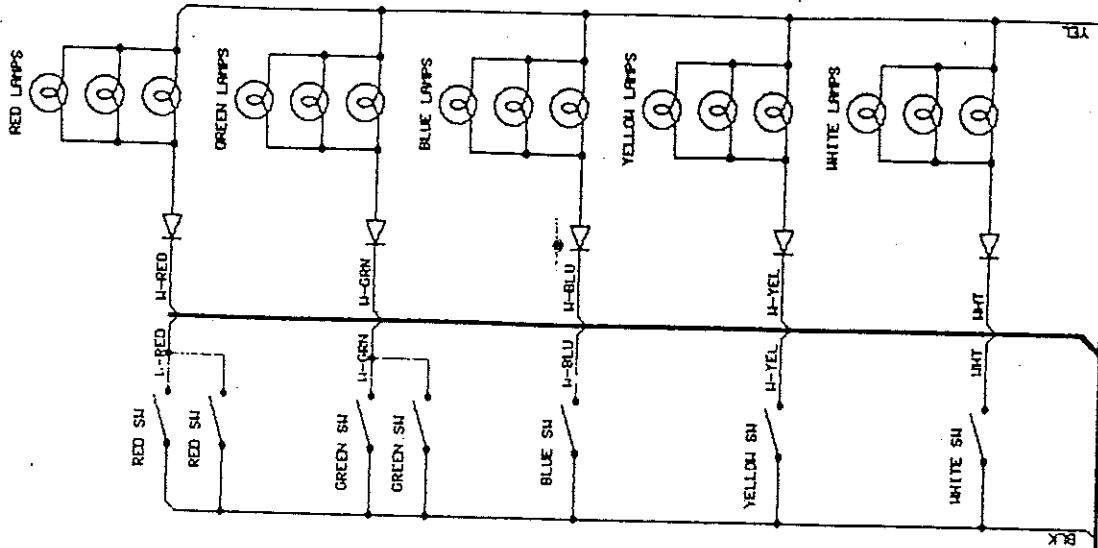

| | |
|--|----------|
| BROMLEY INC. | |
| TITLE COLOR RAMA TILT AND DRUM ASSY WIRING | |
| DATE / / | DWG. NO. |
| SHEET | 12 OF 12 |

LAMP MOUNTING ASSEMBLY

ASSEMBLE LAMP CAPS, COLORS AS SHOWN

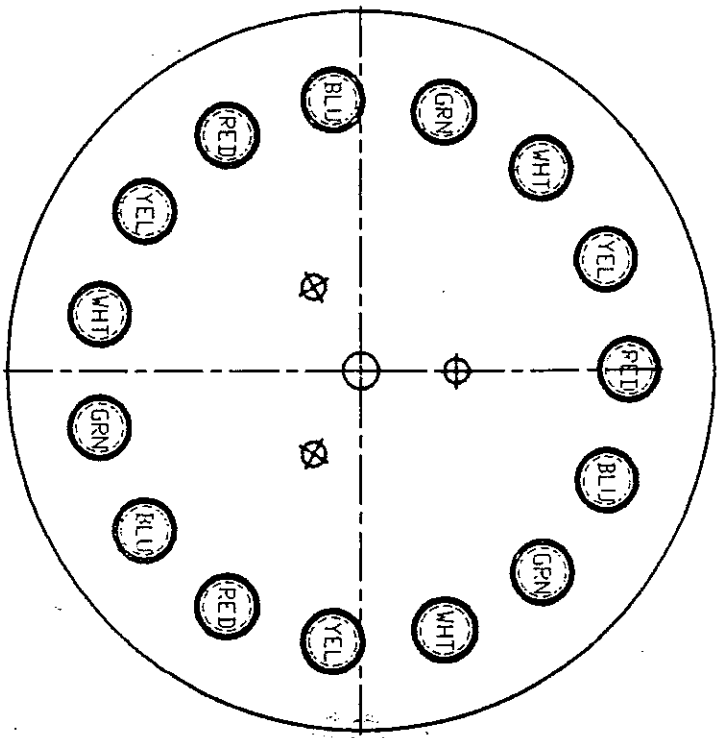

- LAMP CAP
- 0056-104-000 RED
 - 0056-104-001 BLUE
 - 0056-104-002 GREEN
 - 0056-104-003 WHITE
 - 0056-104-004 YELLOW
 - 3 EA RED

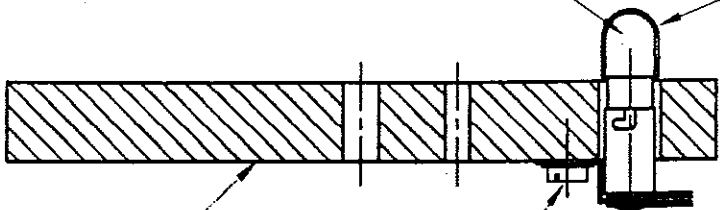

VIEW A-A

LAMP
15 RED
0056-013-000

LAMP MTG
1 RED
R121-606-000

#8x1/2" LG SL HW
15 RED
0005-231-111

LAMP HOLDER
15 RED
0056-061-100

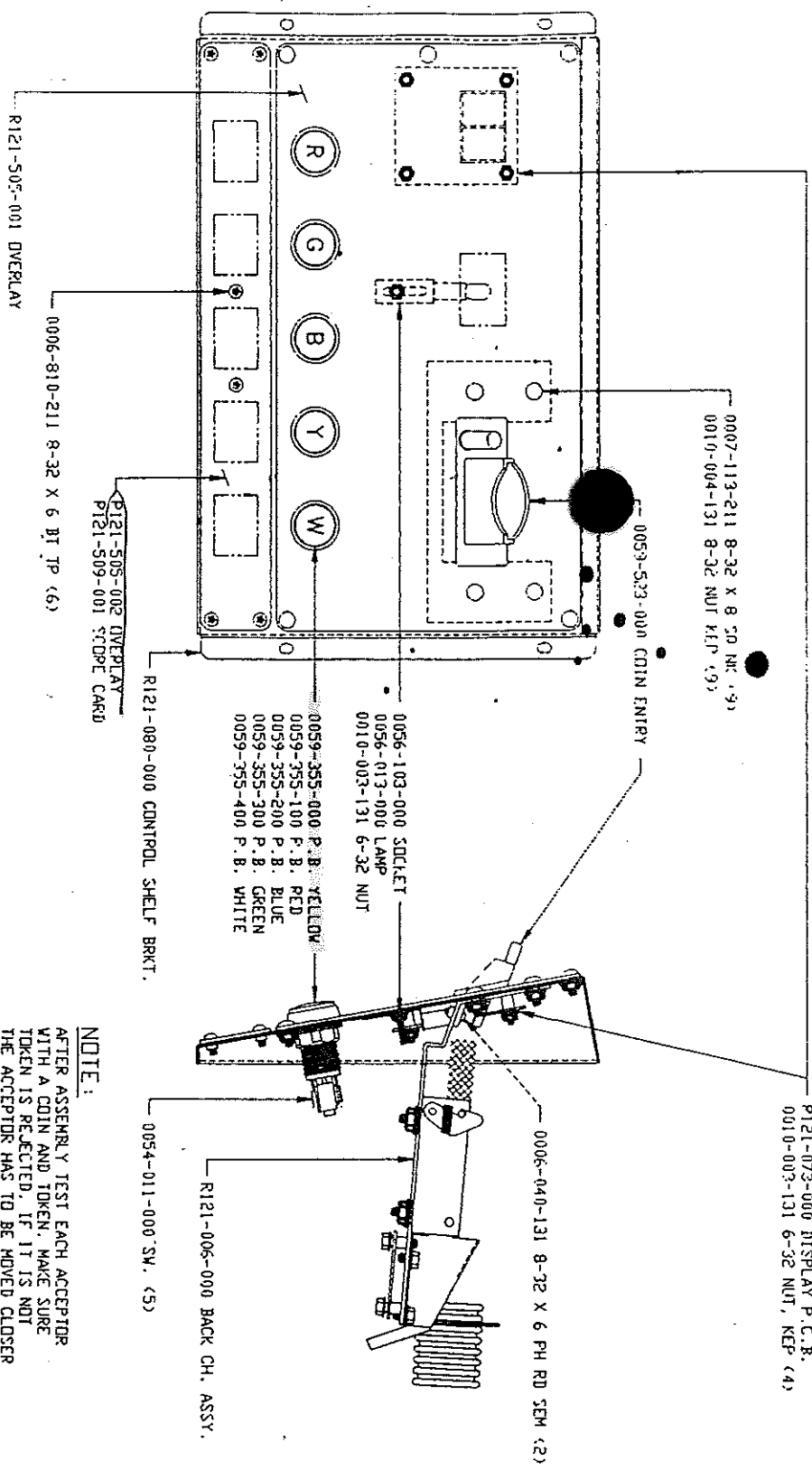

CONTROL SHELF ASSEMBLY

NOTE:
 AFTER ASSEMBLY TEST EACH ACCEPTOR WITH A COIN AND TOKEN. MAKE SURE TOKEN IS REJECTED. IF IT IS NOT THE ACCEPTOR HAS TO BE MOVED CLOSER TO THE COIN CHUTE.

| | | | |
|--------------|------------------|----------|--------------|
| R121-042-001 | CONTROL PANEL #1 | CABLE #1 | P121-059-000 |
| R121-042-002 | CONTROL PANEL #2 | CABLE #2 | R121-060-000 |
| R121-042-003 | CONTROL PANEL #3 | CABLE #3 | R121-061-000 |
| R121-042-004 | CONTROL PANEL #4 | CABLE #4 | R121-062-000 |

WIPER RING
8 REQD
0031-017-911

WIPER PIN
8 REQD
0104-316-000

CONTACT BLOCK ASSY
1 REQD
R121-014-000

SPRING
8 REQD
0037-071-000

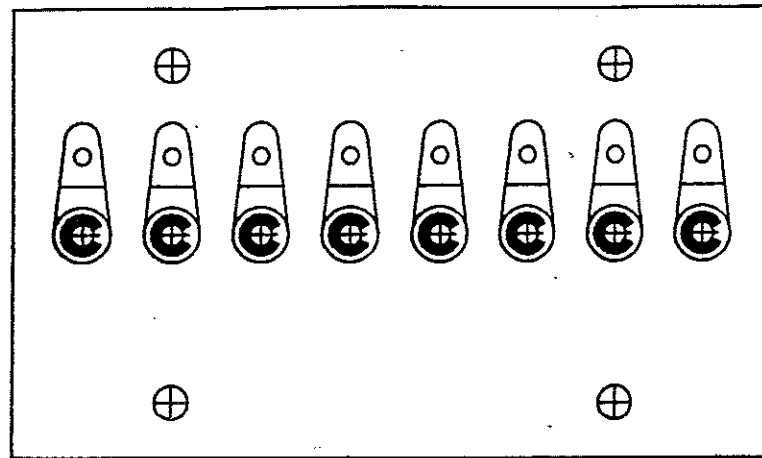

CONTACT ASSEMBLY

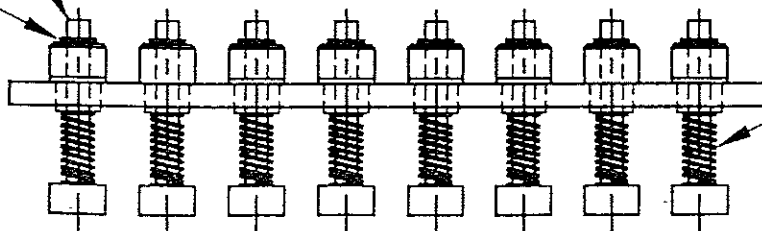

SWITCH
1 REQD
0054-091-000

PUSH NUT
1 REQD
0054-092-000

SWITCH ACTUATOR
1 REQD
0054-017-006

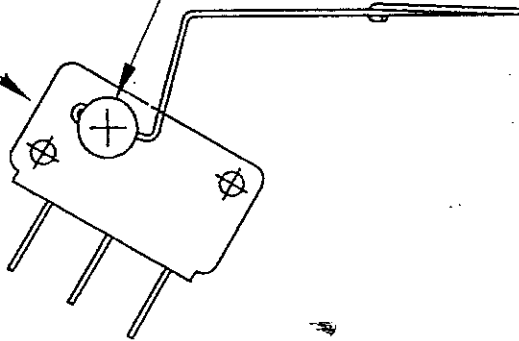
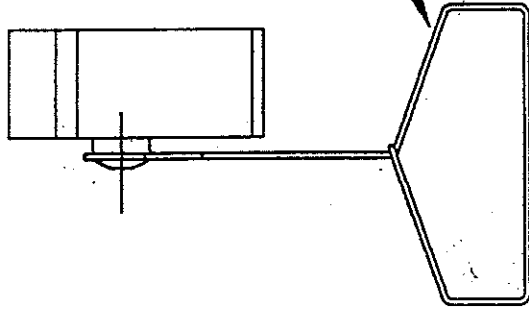

SWITCH ASSEMBLY

R121-033-000

COLORAMA

MARQUEE SET-UP INSTRUCTIONS

- UNCRATE GAME AND LOCATE BLACK SQUARE TUBES (2) WITH CABLES.
- REMOVE HARDWARE BAG FROM CASHBOX. (4) HEX. HD. BOLTS 1/4-20
- TUBE WITH LARGE CABLE BUNDLE SHOULD BE INSERTED INTO SQ. HOLE AT REAR RIGHT SIDE AS YOU STAND FACING BACK DOOR.

FEED CABLE BUNDLE THROUGH CAREFULLY. SET HEIGHT AND SCREW BOLT THROUGH HOLE. REPEAT THIS PROCEDURE FOR LEFT SIDE. MAKE SURE BOTH TUBES ARE AT SAME HEIGHT.

CAUTION ! NEXT STEP IS A TWO MAN OPERATION

- LOCATE MARQUEE BOX AND REMOVE ONE SIDE DISPLAY GLASS.
- WHILE FITTING BOX OVER TUBES, FEED CABLE BUNDLE THROUGH CAREFULLY.
- BOX WILL SLIDE DOWN ON TUBES UNTIL THEY HIT STOPS.
- INSERT HEX. HD. BOLTS AND TIGHTEN SECURELY.
- TIGHTEN THE FOUR (4) HEX. NUTS THAT CLAMP THE BRACKETS TIGHT AGAINST THE TUBES. TIGHTEN ALL THE NUTS AT ALL FOUR BRK'TS.

THIS WILL PREVENT THE MARQUEE BOX FROM EXCESS MOVEMENT.

- PLUG CABLE CONNECTORS TOGETHER IN MARQUEE BOX & MAIN CABINET.
- CAREFULLY REPLACE DISPLAY GLASS. YOUR GAME IS NOW READY TO TURN ON.