

New Game Registration

**REGISTERING YOUR NEW GAME ENTITLES YOU TO AN EXTENDED WARRANTY*
ADD 3 MONTHS TO THE WARRANTY OF THIS GAME BY COMPLETING AND
SUBMITTING, BY FAX OR MAIL, THIS FORM.**

Game Name <small>(one game per card)</small> :	Date:
Game Serial Number <small>(located on the back of the cabinet)</small> :	<p style="text-align: center;">Game Location Type Please Check One:</p> <p><input type="checkbox"/> Family Fun Center</p> <p><input type="checkbox"/> Sports Bar</p> <p><input type="checkbox"/> Bar</p> <p><input type="checkbox"/> Restaurant</p> <p><input type="checkbox"/> Laundromat</p> <p><input type="checkbox"/> Movie Theatre</p> <p><input type="checkbox"/> Mall</p> <p><input type="checkbox"/> Other (please specify)</p>
Game Owner/Operator Company Name:	
Game Owner/Operator Address:	
Game Owner/Operator City/State/Zip:	
Game Owner/Operator Phone Number:	
Game Owner/Operator Fax Number:	
Game Owner/Operator E-Mail Address:	
Game Location Name and Address:	

*NOTE: Extended warranty only applies if ALL boxes on this form are complete. One game per form. Extended warranty does not apply to used or close-out games.



Bay Tek Games Inc.
 1077 East Glenbrook
 Drive
 Pulaski, WI 54162
 Fax: 920.822.8936
 Phone: 920.822.3951
www.baytekgames.com



**We Aspire To Be The Best
In The World At
Developing And Manufacturing
Coin Operated Games For Our Customers.**

Record this Information for Future Reference

Serial Number

Date of Installation

Installed by

Bay Tek Games Inc.
1077 East Glenbrook Dr.
Pulaski, WI 54162
On the web: baytekgames.com
E-Mail: service@baytekgames.com

Service: 920.822.3951 EXT. 1102
Parts: 920.822.3951 EXT. 1101
Fax: 920.822.8936
Service Fax: 920.822.1496
Sales: 920.822.3951



About American Idol Super Star™

You're going to be a Super Star with this all new prize merchandiser by Bay Tek Games.

American Idol Super Star (TM) is a fun, addicting light pattern game that brings the #1 Show in America to your location. Players press the stop button to light five stars in a row for a minor prize, or they can choose to play on for a Super Prize! The Super Prize is won by lighting up five more stars as the difficulty increases.

This exclusive skill game offers:
American Idol (TM) artwork, audio, and prizes for fans of all ages. American Idol is #1 on Yahoo's Top Entertainment Search.
Be Part of The Phenomenon!



Operation and Set Up

Safety Precautions



CAUTION: Electric Shock Hazard
Do not perform repairs or maintenance on this game with the power ON.

Unplug the unit from the wall outlet or shut off power at the power strip inside the game.



CAUTION: Electric Shock Hazard
Always plug game into grounded circuit.



CAUTION: Use of flammable substances can cause severe burns or personal injury.

Always use non-flammable solvents for cleaning parts and surfaces. Do not use substances such as gasoline, kerosene, or thinners.

Unpacking, Assembly, and Installation

Inspect the game for any damaged, loose, or missing parts. If damage is found please contact the carrier first. Then contact Bay Tek Games at [920.822.3951](tel:920.822.3951) or service@baytekgames.com to order replacement parts.



CAUTION: Lifting Hazard.
Lifting heavy objects can cause back, neck, and other injuries.

Be sure adequate lifting and moving devices are available when unloading, unpacking, and moving this game.

Service Connections

All Bay Tek games are **110V** or **220V** (optional) and draw 2-3 amps at start up. Outlets should be rated for 20 amps or higher.

Important:

Be sure that the electrical power outlets match the games requirements. See the serial number decal on the back of the game.

Set Up

1. Remove the keys from the coin return hole on the coin door.
2. Open the front door and remove the marquee from the inside of the game cabinet.
3. Install the marquee, see page 5.
4. Unlock and remove the back door. Retrieve the extension cord from the floor of the game and plug it into the line filter in the back of the cabinet. Replace the backdoor.
5. Move the game into position and plug it in. Turn ON the power strip located on the floor in the front of the game, left of the prize chute.
6. Remove the anti drop bars from the cash box. Load the prizes, see page 8.
7. Adjust the settings as appropriate to your location, starting on page 12.
8. Close and lock the front door.
9. Clean the exterior windows with glass cleaner and a clean soft cloth.

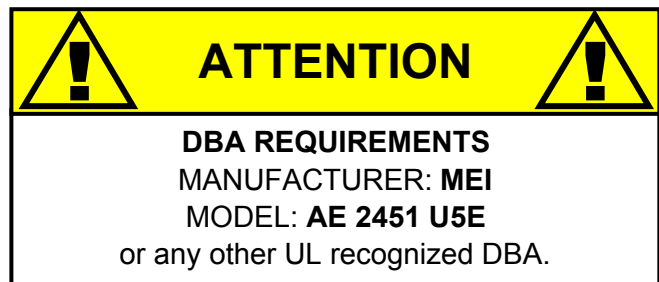

Installing the Marquee

1. Remove the marquee from inside the game and unwrap it.



2. Place the marquee on top of the game plug in the cables.

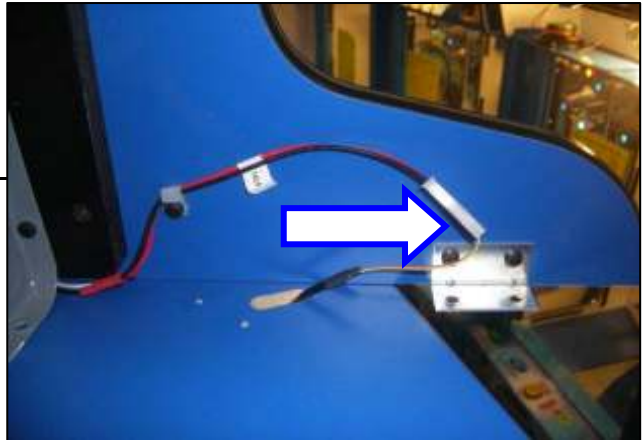

3. Feed the cable slack back into the cabinet.

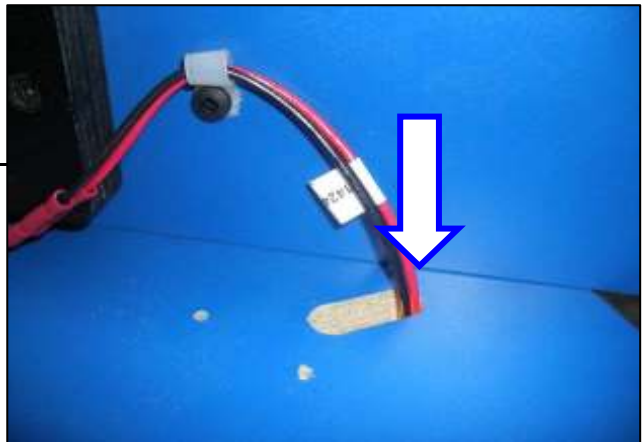

4. Attach the marquee using the provided hardware and the pilot holes at the top of the cabinet.

Complete.

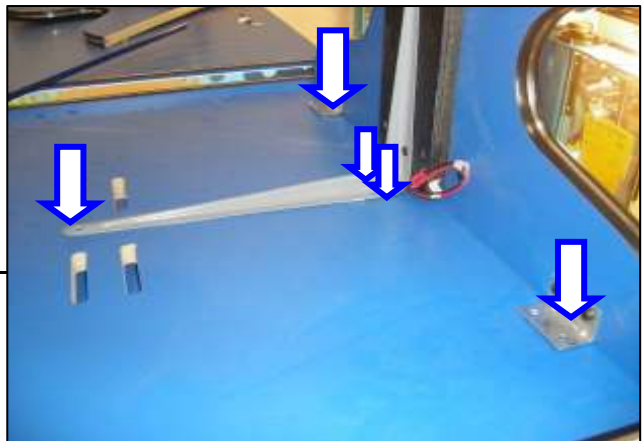

Prize Information

Quantity of Prizes

Small: Approx. 60 to fill game depending on packaging.

Super Prizes: 2-4 based on packaging

For operator convenience you can also use non-licensed kits available thru your local prize suppliers. "Stacker" type kits do work in this game. We encourage you to be as creative as possible by operating prizes which suite the theme and play of American Idol (TM).

Preferred Prize Vendors

Bonita Marie
800-272-6375
1975 Swarthmore Avenue
Lakewood, NJ 08701
bonitamarie-intl.com

HMS Monaco
800-777-0901
629 Grove Street
Jersey City, NJ 07310
hmsmonaco.com
(does not supply super prizes)

Playtime Toys
888-457-8697
6235 Edgewater Drive
Orlando, FL 32810
playtimetoys.net

Quarter Time
276-688-2401
7107 North Scenic Highway
Bastian, VA 24314

Redemption Plus
888-564-7587
9829 Commerce Parkway
Lenexa, KS 66219
redemption-plus.com

Prize Fasteners

When preparing your prizes for loading we suggest using a tagging gun to add the necessary loop fasteners needed to hold the prize on the spindles. You may find the tagging guns:

Midwest Merchandising, Inc.
P.O. Box 2611
Oshkosh, WI 54903-2611

Phone: 920-231-0625

Fax: 920-231-5304

www.midwestm.com

info@midwestm.com

Avery Dennison Mark III Tagging Gun: #10651

**Avery Dennison 3" Heavy Duty Loop
Fasteners # 08989-0**

Avery Dennison Needles: Packs of 4

General Duty: 08941

Heavy Duty: 08913

Prize Ideas

Small Prize (Round 1)	Tattoo's, dog tags, sport items, flashing necklace, key chains, glo mouth guards, and bracelets
Super Prize (Round 2)	iPods, PSP, Pre-Paid Cell Phones, iPod Accessories, DVD players, Bluetooth Earpieces, Designer Purses, and Electronics

Suggested Prize Measurements

To ensure proper operation we recommend the following measurements for the prizes.



Spindles 1, 2, 5, and 6

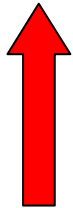

**7.5 inches
long**

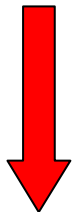

**Width
3 inches**

Spindles 3 and 4

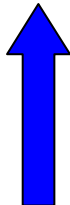

**4.5 inches
long**

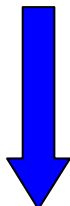

**Width
3 inches**

Spindles 7 and 8



The total length of this page.

**11 inches
long**

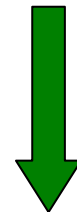

**7 inches wide
5 inches deep**

Loading the Prize Spindles

1. Remove the anti drop bar by unscrewing it clockwise.

If this is your initial setup remove the bars from the cash box.



2. Slide the prizes over the spindles.
Every other coil works the best.
Try to not have the prizes touch one another.
-



3. Slide the anti drop bar back in.
It is **very important** that the bar goes over the fastener holding the prize.
-

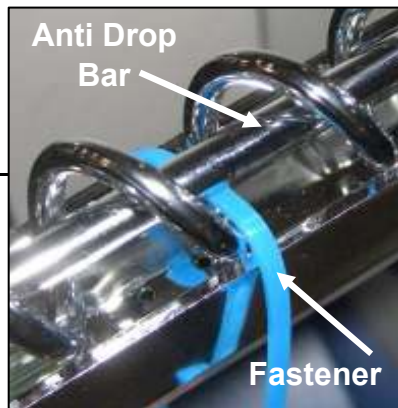

4. Screw the anti drop bar back into place by turning it counter clockwise.
-



This decal is for **fluorescent light** replacement. This decal is located near the fluorescent lights in the game.

The top one can be found on 110V games.

The bottom one can be found on 220V games.



RISK OF FIRE
USE 26 WATT OR SMALLER 120V SPIRAL COMPACT FLUORESCENT BULBS.



RISK OF FIRE
USE 22 WATT OR SMALLER 240V SPIRAL COMPACT FLUORESCENT BULBS.

The **large serial number** decals are located on the back of the cabinet and inside the front door. The information on this decal will be needed if you call the Bay Tek Parts and Service Department.

Model: The completed games Bay Tek part number

PCB Serial Number : Each Bay Tek PCB is serial numbered. This number is included on the large serial number decal.

Software Version: The installed software in this game.

Manufacture Date: The date the game was completely built and ready to ship.

Game Serial Number : The first number is the cabinet version, followed by the game serial number.

Inspected By: Initials of the Bay Tek employee who looked the game over and played it several times to insure proper function.

SUITABLE FOR INDOOR USE ONLY	
MODEL:	~110-120 VAC 50-60 Hz 2 AMPS
SOFTWARE VERSION:	
GAME SERIAL NUMBER:	
PCB SERIAL NUMBER:	
MANUFACTURE DATE:	
INSPECTED BY:	
AMUSEMENT MACHINE	
 www.baytekgames.com	

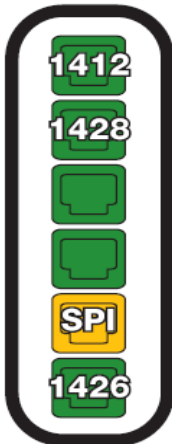

Main Board Cable Mapping - Located near the PCB and will help identify where each cable goes and what the cable function is.

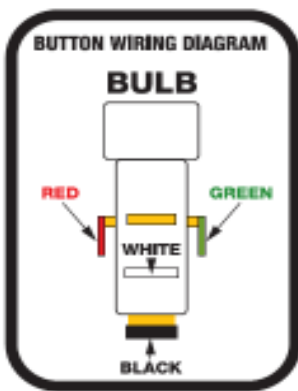

Player Button Wiring - Will identify how to wire the player buttons in case they ever need replacement.

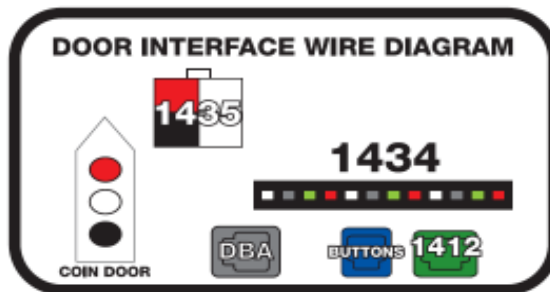

Door Interface Board Wiring - Identifies the wiring of the door interface board located on the front door.

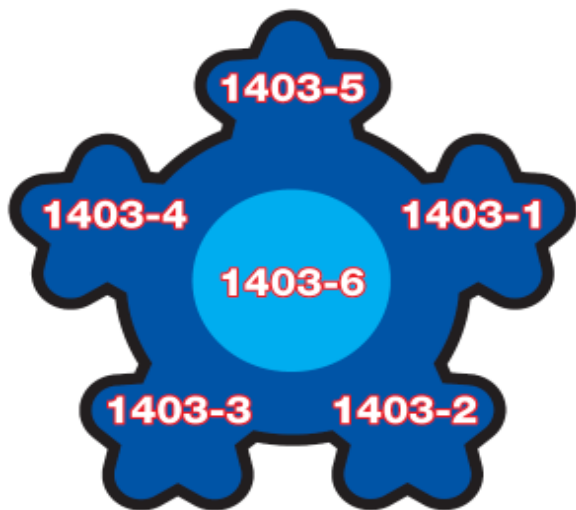

Star Board Cable Mapping - Identifies the locations of the cables on the playfield circuit boards. This decal is located near the playfield inside the game cabinet.

Timeout Information

American Idol Super Star™ has several timeouts so the game play is more consistent.

Game is coined up with no player activity	5 minutes	The game credit will be lost and they game will be ready for the next player
Game is in the Diagnostic Mode with no operator activity	1 minute	The game will go into normal game play mode
Once the game is turned on	10 seconds	The game will be ready to play
Player control button jam	30 seconds	An error will appear on the LCD and remain until the jam is fixed.
Coin jam	30 seconds	An error will appear on the LCD and remain until the jam is fixed.
Player chooses a small prize spindle that is empty	28 seconds	The player will have a second opportunity to chose a different small prize
Player chooses a super prize spindle that is empty	65 seconds	The player will have a second opportunity to chose a different super prize

OPERATOR CONTROL MENU

This section will explain how to use the LCD screen in the center of the star playfield to change game functions and monitor game metrics.

The screen shots used in the following are of the default dip settings.
The screen images may change if you set the dips differently.

See dip programming options on page 27.

All screen images are actual.

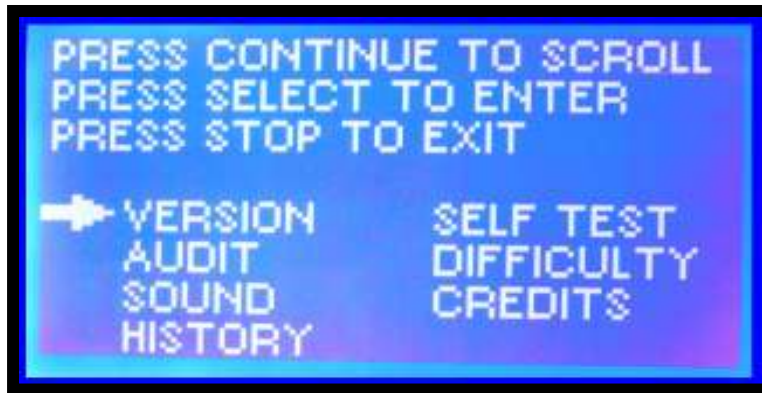

FUNCTION	DEFINITION	PAGE
VERSION	Allows you to see the current software version installed in the game.	13
AUDIT	Allows you check game statistics such as prizes won per spindle and timeouts.	14
SOUND	Allows you to change the volume level and the attract mode.	16
HISTORY	You can view win/lose information on the last 10 games played	18
SELF TEST	Allows you to check playfield lighting and motor function.	19
<i>Difficulty Setting Suggestions</i>	<i>Recommended settings based on cost per game.</i>	<i>20</i>
DIFFICULTY	Will show you how to change your settings	21
CREDITS	Allows you to set the currency used and cost per game	23

VERSION

1. Press the **MENU** button located near the counters.
The screen on the playfield will show the **Operator Control Menu**



2. Press the "**SELECT PRIZE**" button on the player control panel to access the **VERSION** screen.



3. Press the "**START/STOP**" button on the player control panel once to return to the Operator Control Menu or twice to exit and return to normal game play.



AUDIT

1. Press the **MENU** button located near the counters.
The screen on the playfield will show the **Operator Control Menu**



PRESS CONTINUE TO SCROLL
PRESS SELECT TO ENTER
PRESS STOP TO EXIT

→ VERSION	SELF TEST
AUDIT	DIFFICULTY
SOUND	CREDITS
HISTORY	

2. Press the "**CONTINUE**" button on the player control panel to move the cursor to **AUDIT**.

A green rectangular button with the word "CONTINUE" printed in black.

3. Press the "**SELECT PRIZE**" button on the player control panel to access the **AUDIT** screens.

A red rectangular button with the words "SELECT PRIZE" printed in black.

PRESS 'CONTINUE' FOR NEXT SCREEN
PRESS 'STOP' TO EXIT

TOTAL GAMES	0
ROUND 1 WINS	0
ROUND 1 PRIZES DISP	0
ROUND 1 CONTINUES	0
ROUND 2 WINS	0
ROUND 2 PRIZES DISP	0

4. To change between the 5 screens press the "**CONTINUE**" button. You can not go back a screen, you will need to start over.

To exit press the "**START/STOP**" button once to return to the Operator Control Menu or twice to return to normal game play.

A green rectangular button with the word "CONTINUE" printed in black.

Resetting the AUDIT METRICS

1. The metric information can be reset to zero by pressing the "**SELECT PRIZE**" and "**CONTINUE**" buttons at the same time.



2. Press the "**START/STOP**" button on the player control panel once to return to the Operator Control Menu or twice to exit and return to normal game play.



SOUNDS

1. Press the **MENU** button located near the counters.
The screen on the playfield will show the **Operator Control Menu**



2. Press the "**CONTINUE**" button on the player control panel to move the cursor to **SOUNDS**.



3. Press the "**SELECT PRIZE**" button on the player control panel to access the **SOUNDS** menu.



Cursor

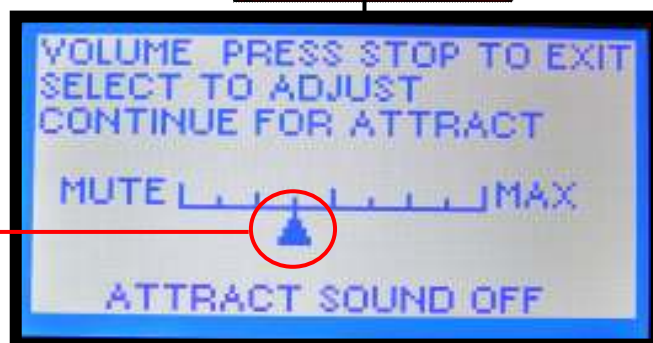

4. Press the "**SELECT PRIZE**" button on the player control panel to adjust the cursor on the volume level bar.



5. Press "**CONTINUE**" button on the player control panel to turn the attract mode ON or OFF.
If ON please see page 26 for timer options.



SOUNDS

6. Press the "**START/STOP**" button on the player control panel once to return to the Operator Control Menu or twice to exit and return to normal game play.



HISTORY

1. Press the **MENU** button located near the counters.
The screen on the playfield will show the **Operator Control Menu**



PRESS CONTINUE TO SCROLL
PRESS SELECT TO ENTER
PRESS STOP TO EXIT

→ VERSION	SELF TEST
AUDIT	DIFFICULTY
SOUND	CREDITS
HISTORY	

2. Press the "**CONTINUE**" button on the player control panel to move the cursor to **HISTORY**.

CONTINUE

3. Press the "**SELECT PRIZE**" button on the player control panel to access the **HISTORY** screen.

SELECT PRIZE

GAME HISTORY STOP TO EXIT

1 LOSE	6 LOSE
2 LOSE	7 LOSE
3 LOSE	8 LOSE
4 LOSE	9 LOSE
5 LOSE	10 LOSE

4. Press the "**START/STOP**" button on the player control panel once to return to the Operator Control Menu or twice to exit and return to normal game play.



SELF TEST

1. Press the **MENU** button located near the counters.
The screen on the playfield will show the **Operator Control Menu**



2. Press the "**CONTINUE**" button on the player control panel to move the cursor to **SELF TEST**.



3. Press the "**SELECT PRIZE**" button on the player control panel to access the **SELF TEST** screen.

During the self test the playfield lighting will flash, the spindles will rotate one at a time while the yellow indicator light is lit, the player control buttons will flicker.



4. Press the "**START/STOP**" button on the player control panel once to return to the Operator Control Menu or twice to exit and return to normal game play.



DIFFICULTY SETTING SUGGESTIONS

Bay Tek Games can proudly state our games, including **American Idol Super Star (TM)**, are games of skill.

Because they are games of skill, the payout percentage will vary based upon the skill level of the players in your venue.

The follow recommendations are based on the outcome of player studies, and should only be used as a general guideline.

The target payout percentage for the following tables is *approximately 30%*.

.50 Per Play Option 1			.50 Per Play Option 2			.50 Per Play Option 3					
		Cost	Difficulty Setting			Cost	Difficulty Setting			Cost	Difficulty Setting
Small Prize		\$.50	Round One (3)			\$.75	Round One (3)			\$.50	Round One (3)
Super Prize		\$50	Round Two (4)			\$75	Round Two (6)			\$125	Round Two (6)

1.00 Per Play Option 1			1.00 Per Play Option 2			1.00 Per Play Option 3					
		Cost	Difficulty Setting			Cost	Difficulty Setting			Cost	Difficulty Setting
Small Prize		\$.75	Round One (3)			\$1.50	Round One (3)			\$.75	Round One (3)
Super Prize		\$150	Round Two (5)			\$150	Round Two (6)			\$250	Round Two (6)

2.00 Per Play Option 1			2.00 Per Play Option 2			2.00 Per Play Option 3					
		Cost	Difficulty Setting			Cost	Difficulty Setting			Cost	Difficulty Setting
Small Prize		\$1.50	Round One (3)			\$1.50	Round One (3)			\$1.50	Round One (3)
Super Prize		\$150	Round Two (4)			\$250	Round Two (4)			\$350	Round Two (5)

DIFFICULTY

1. Press the **MENU** button located near the counters.
The screen on the playfield will show the **Operator Control Menu**



3. Press the "**CONTINUE**" button on the player control panel to move the cursor to **DIFFICULTY**.



4. Press the "**SELECT PRIZE**" button on the player control panel to access the **DIFFICULTY** screen.



5. The first screen is for changing Round 1. Press the "**SELECT PRIZE**" button on the player control panel to move the selector arrow to the desired level.

Moving the cursor to the **LEFT** will make the round *easier* to win.

Moving the cursor to the **RIGHT** will make the round *harder* to win.

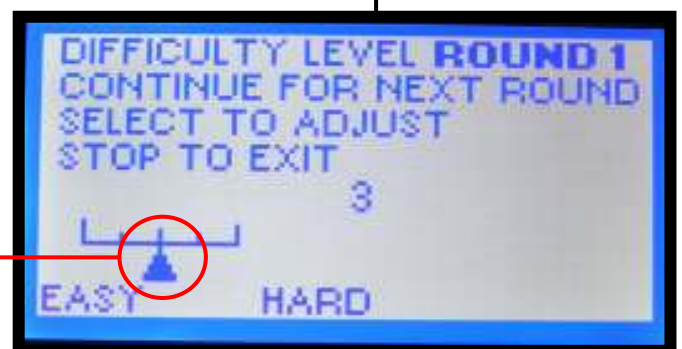

Selector Arrow

DIFFICULTY

6. Press the "**CONTINUE**" button on the player control panel to adjust Round 2.



7. The second screen is for changing Round 2.

Press the "**SELECT PRIZE**" button on the player control panel to move the cursor to the desired level.

Moving the cursor to the **LEFT** will make the round *easier* to win.

Moving the cursor to the **RIGHT** will make the round *harder* to win.



Selector Arrow

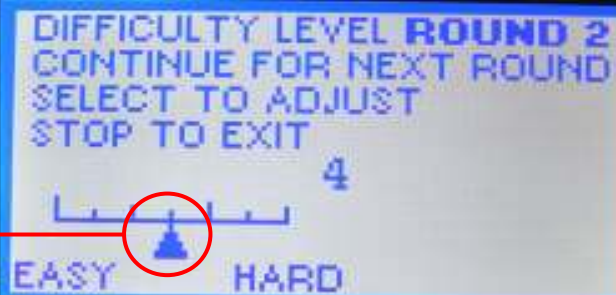

8. Press the "**START/STOP**" button on the player control panel once to return to the Operator Control Menu or twice to exit and return to normal game play.



CREDITS

1. Press the **MENU** button located near the counters.
The screen on the playfield will show the **Operator Control Menu**



2. Press the "**CONTINUE**" button on the player control panel to move the cursor to **CREDITS**.



3. Press the "**SELECT PRIZE**" button on the player control panel to access the **CREDITS** screen.



4. Press the "**CONTINUE**" button on the player control panel to select your currency.



The choices are:
DOLLARS
COINS
EURO
POUNDS
TOKENS

CREDITS

5. Once you have selected a currency you may now adjust the cost per game by pressing the "**SELECT PRIZE**" button on the player control panel.



DOLLARS	COINS	EURO
.25	1 COIN	.30
.50	2 COINS	.50
.75	3 COINS	1.00
1.00	4 COINS	2.00
1.25	5 COINS	FREE PLAY
1.50	6 COINS	
1.75	7 COINS	
2.00	8 COINS	
FREE PLAY	FREE PLAY	

POUNDS	TOKENS
.30	1 TOKEN
.50	2 TOKENS
1.00	3 TOKENS
2.00	4 TOKENS
FREE PLAY	5 TOKENS
	6 TOKENS
	7 TOKENS
	8 TOKENS
	FREE PLAY

6. Press the "**START/STOP**" button on the player control panel once to return to the Operator Control Menu or twice to exit and return to normal game play.



PCB (Printed Circuit Board)

DIP SWITCHES

Dip options can be found on page 26.

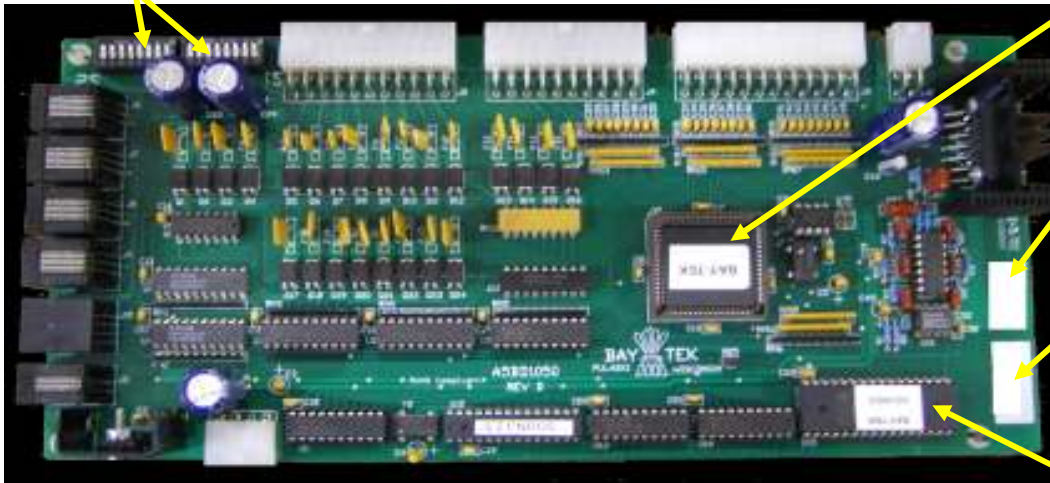

SOFTWARE CHIP

GAME SERIAL NUMBER

PCB SERIAL NUMBER

SOUND CHIP

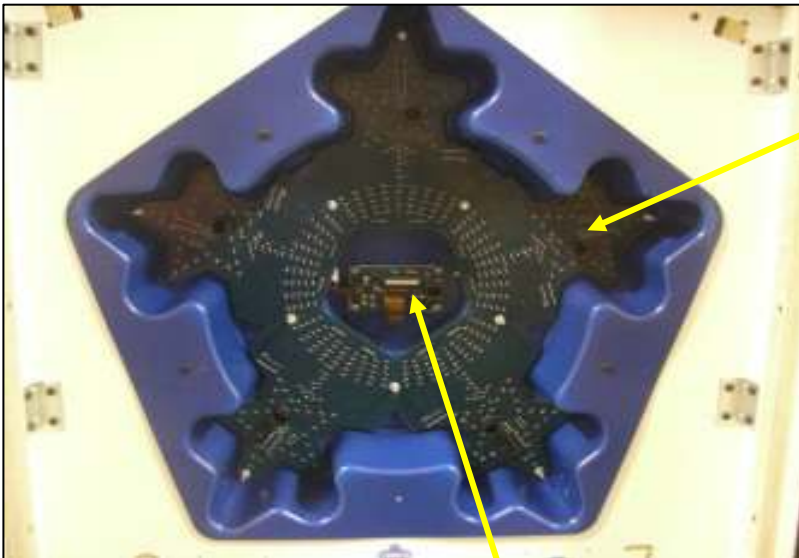

AACB1400
STAR BOARD
(5 PER GAME)

LCD Control Board



LCD CHIP

Electrical drawings can be found starting on page 36.

American Idol Super Star (TM)

To change the factory settings you will need to access the two banks of dip switches located on the **(PCB)** by removing the back door. The switches are located in the upper left corner of the board.

IMPORTANT:

Game power must be OFF before adjusting any of the programming selections. Turn OFF the power strip located on the floor of the game. Set the desired dip switches, wait 30 seconds and turn the game back ON.

Bank 1 Dip 2 N.J. Operation FACTORY DEFAULT = DISABLED	Active - see below	Dip 2 - ON
	Disabled	Dip 2 - OFF
ACTIVE No stored credits -- No 6 plays for \$5.00 Coin comparator and DBA lockout when cost per play is inserted DBA must be disabled or removed in this mode if price per play is less then \$1.00. If there is a power loss during the prize selection/ejection process the player will have another chance to claim a prize when power has been restored.		

Bank 1 Dip 4 START/STOP Button Game start option FACTORY DEFAULT = OFF		Games starts immediately after coin up	Dip 4 ON
		Game starts when yellow button is pressed after coin up	Dip 4 OFF

Bank 1 Dips 5 and 6 Attract Mode Timer FACTORY DEFAULT = 2 MINUTES	Plays every 2 minutes	Dip 5 - OFF	Dip 6 - OFF
	Plays every 5 minutes	Dip 5 - OFF	Dip 6 - ON
	Plays every 10 minutes	Dip 5 - ON	Dip 6 - OFF
	Disabled	Dip 5 - ON	Dip 6 - ON

Bank 1 Dip 7 Round 2 10th. Star Win Window FACTORY DEFAULT = NORMAL	EASY	Dip 4 ON
	NORMAL	Dip 4 OFF

Bank 1 Dips 1, 3, and 8 UNASSIGNED and should remain OFF	Dip 1 OFF	Dip 3 OFF	Dip 8 OFF
---	--------------	--------------	--------------

Bank 2 ALL DIPS UNASSIGNED and should remain OFF	Dip 1 OFF	Dip 2 OFF	Dip 3 OFF	Dip 4 OFF	Dip 5 OFF	Dip 6 OFF	Dip 7 OFF	Dip 8 OFF
---	--------------	--------------	--------------	--------------	--------------	--------------	--------------	--------------

IMPORTANT:

*Game power must be OFF before removing or installing any programming chip.
Turn OFF the power strip located on the floor of the game.*

Install Program Chip

1. You will notice a small dimple on one edge of the chip.

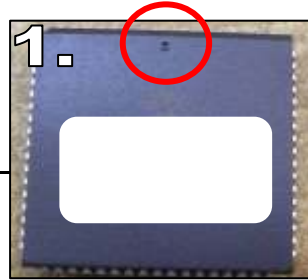

2. That dimple should line up with an arrow in the socket on the board.

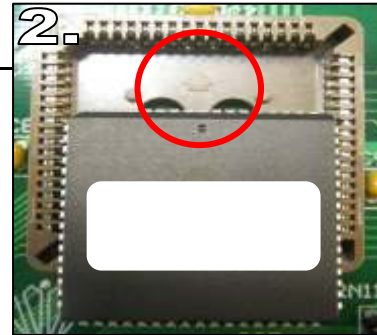

3. Line the legs of the chip with the slots in the socket and push the chip in evenly.

NOTE: The legs on the chip should not be bent at all.



Install Sound Chip - Install LCD Chip

1. You will notice a small notch on one edge of the chip.

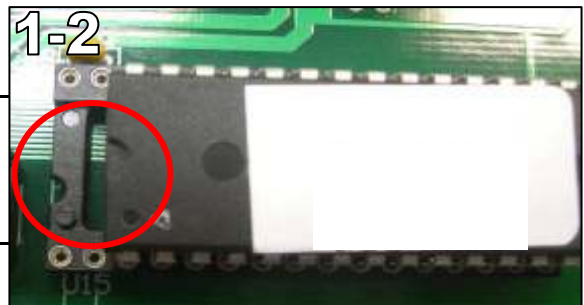

2. That notch should line up with a notch in the socket on the board.

3. Line the legs of the chip with the slots in the socket and push the chip in evenly.

NOTE: The legs on the chip should not be bent at all.



Use the following procedure to check the Power supply for Gen 5 games.
 Check the small green LED light on the power supply circuit board. If the light is out there is a short somewhere. If the light dims, there is an overload in one of the circuits such as a bad motor.

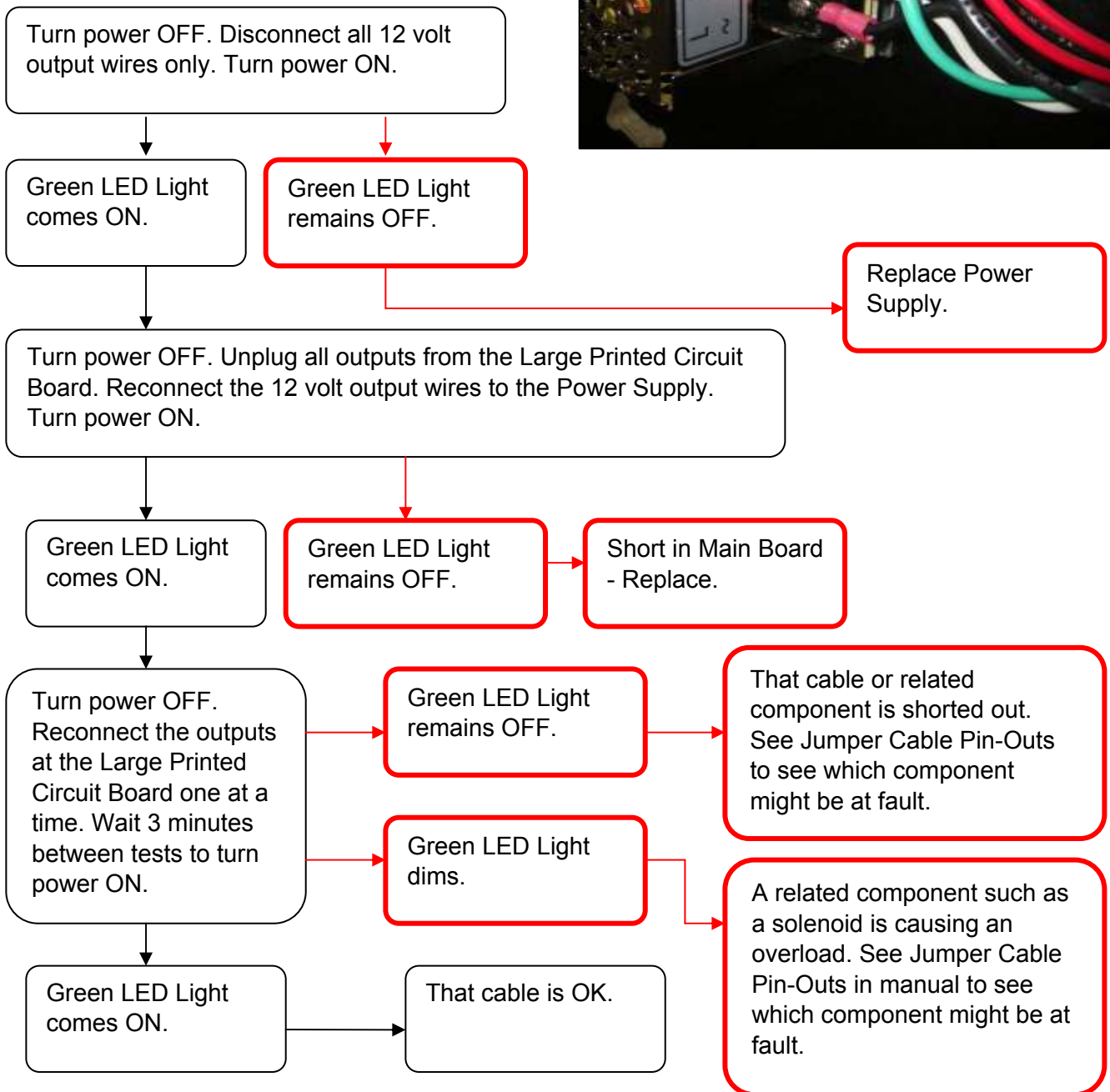











Maintenance Chart

Use the following maintenance chart as a guide only. Actual maintenance intervals will depend on usage and environmental conditions at the location of the game.

Keep a log of all inspections, even if no problem exists, with date and time of inspection, action taken. A Repair Record form is included at the end of this manual.

IMPORTANT: Do not use cleaning solvents on game graphics. Use only a mild soap solution and dry with a clean lint free cloth.

IMPORTANT: The game should be shut OFF for cleaning and maintenance.

Action	Daily	Weekly	Quarterly	Yearly
Check Prizes and fill as necessary.				
Inspect game for physical damage. Repair as necessary.				
Inspect game lighting and replace lamps as necessary.				
Clean outside surfaces and glass.				
Empty cash box and DBA.				
Open game and clean playfield and inner surfaces with a clean soft cloth and glass cleaner.				
Test to insure game is working properly.				
Clean/vacuum the prize chute.				
Clean DBA with bill reader cleaning card.				
Test prize dispensing sensor.				
Check all hardware for tightness.				

Troubleshooting and Diagnostic Section

Troubleshooting Strategy

Use a systematic method of troubleshooting to determine the exact problem, probable cause and remedy. Use the process of elimination to find the faulty component. Always check for the simple and obvious causes first such as unplugged, loose or broken wires and bad sensors, bent, pinched, stuck or jammed components.

Troubleshooting Chart

Problem	Probable Cause	Remedy
No power to the game.	Unplugged	Check wall outlet
	Game's power strip circuit breaker tripped	Reset power strip breaker switch on inside of cabinet
	Faulty power supply	See power supply diagnostics. Replace if needed. (A5PS1001)
No Audio	Volume too low	Increase the volume, page 14
	Loose wire	Check audio cable connections from speakers to right side of Aux board
	Main printed circuit board malfunction	Replace printed circuit board with a spare printed circuit board if possible to isolate the problem to the main circuit board
Attraction lighting not working properly	Cable problem	Check and repair black telephone cable to main board
	Poor jumper board connections	Check and repair jumper board connections
	PCB malfunction	Replace PCB with a spare PCB if possible to isolate the problem to the PCB.

Troubleshooting Chart

Problem	Probable Cause	Remedy
---------	----------------	--------

Problem	Probable Cause	Remedy
Game lighting not functioning properly	Faulty light in marquee	Replace bulb with 26 watt 120 volt mini spiral compact florescent bulb. (A5LI0001)
	Inside cabinet lighting out	Replace bulb with 26 watt 120 volt mini spiral compact florescent bulb. (A5LI0001)
	Lamp socket damaged	Replace faulty sockets (A5SC5002)
	Bad power supply	See power supply diagnostic. Replace if faulty. (A5PS1001)
"START/STOP" button does not work 	"START/STOP" switch faulty	Replace stop switch. (A5PBAC003)
	Phone cables on right side of Aux in wrong position	Ensure "audio" and "buttons" plugs are in correct position on Aux board
	Phone cable sockets dirty on either end of cable	Clean phone cable and sockets
No coin up or bill credit	Black phone cables in wrong position on door interface board	Ensure "DBA" and "1412" plugs are in correct position on door interface board
	Phone cable sockets dirty on either end of cable	Clean phone cable and sockets
	Faulty coin switch and bad bill acceptor signal	Replace coin switch. (AASW2700) and refer to Bill Acceptor not functioning below
	Faulty PCB	Replace PCB with a spare PCB if possible to isolate the problem to the PCB

Troubleshooting Chart

Problem	Probable Cause	Remedy
---------	----------------	--------

Problem	Probable Cause	Remedy
<p>Game goes directly to 2nd round after 1st round win.</p>	The “ CONTINUE ” button is wired incorrectly	The button should be wired normally open, refer to page 10 for wiring diagram.
	The “ CONTINUE ” button is faulty	Replace “ CONTINUE ” button. (A5PBAC002)
<p>Top spindle (1-6) does not dispense prize.</p> <p><i>Spindle will time-out after 28 seconds of turning if no prize falls into prize chute. It will then let you select a different top row prize.</i></p>	Spindle is turning the 30 seconds, but no prize falls into prize chute.	Prizes are not loaded correctly, and slipping on spirals. Refer to prize loading section.
	Spindle does not turn.	Faulty spindle. Replace spindle. (A5DSPZ010)
	Faulty wire, crimp, phone cable connection.	Check wiring from motor to Aux board.
	Test spindles by entering diagnostic mode	Go to self test. The game will then cycle the prize spindles for 10 seconds, then pause 10 seconds, then continue to next spindle.
	Prize stuck left or right on display.	Game thinks prize chute is blocked and will not dispense prize. Refer to Error codes below to remedy.
	Faulty PCB	Replace PCB board with a spare PCB if possible to isolate the problem to the PCB

Troubleshooting Chart

Problem	Probable Cause	Remedy
---------	----------------	--------

Problem	Probable Cause	Remedy
<p>Bottom spindle (7 and 8) does not dispense prize.</p> <p><i>Spindle will time-out after 65 seconds of turning if no prize falls into prize chute. It will then let you select a different bottom row prize.</i></p>	Spindle is turning the 40 seconds, but no prize falls into prize chute.	Prizes are not loaded correctly, and slipping on spirals. Refer to prize loading section.
	Spindle does not turn.	Faulty spindle. Replace spindle. (A5DSPZ010)
	Faulty wire, crimp, phone cable connection.	Check wiring from motor to Aux board.
	Test spindles by entering diagnostic mode	Go to self test. The game will then cycle the prize spindles for 10 seconds, then pause 10 seconds, then continue to next spindle.
	Prize stuck left or right on display.	Game thinks prize chute is blocked and will not dispense prize. Refer to Error codes below to remedy.
	Faulty PCB	Replace PCB with a spare PCB if possible to isolate the problem to the PCB
<p>Game has too many credits.</p>	Game may be in free play mode.	Enter diagnostics and ensure credits are not set to free play.
	Many credits in memory.	To clear memory, enter diagnostics, go to audit section. Press and hold both "continue" and "select prize" buttons down. Note: This will clear all audit functions!

Troubleshooting Chart

Problem	Probable Cause	Remedy
Dollar Bill Acceptor not functioning	Ensure bill acceptor has 110 Volts AC	Acceptor should cycle stacker at game power up. If not, check cable connections to power strip. Caution – 110 Volts AC
	Dirt or debris in acceptor slot.	Clean with bill reader cleaning card.
	Ensure acceptor dipswitch is set to “always enable”	There are dips on side of acceptor. Set to “always enable” (not harness enable)
	Black phone cable in unplugged or in wrong position on door interface board.	Check cable position according to diagram on door.
	Pinched, broken, or disconnected wiring.	Check wiring from bill acceptor to Aux board. Repair or replace wiring harness.
	Bill acceptor problem.	Refer to troubleshooting section of dollar bill acceptor manual included with this game or the diagnostics label of the back of the unit.

Error Code

SENSOR STUCK		Prize chute optos are dirty. Remove wood prize chute and clean optos. <i>Caution: Unplug phone plug before prize chute is removed to avoid damaging cable connection.</i>
	Game thinks something is blocking prize chute. It will not allow a prize to drop. All the lighting in the game that is controlled by the main board is turned OFF.	Prize chute has 2 sensor boards. <i>They are interchangeable</i> . Try swapping left and right boards with each other and see if problem is fixed.
	No additional games will be allowed to be played. If possible the DBA is locked out.	Clean sensor boards, replace if needed. (AACB1401)
	Examine sensor boards. Each board has 4 green LED's. The only one that is supposed to be lit all the time is D19. The other 3 will come on if emitters are blocked. If any of these 3 are lit, board is faulty. If any of these are on dimly – the boards are not perfectly lined up.	Check wiring from sensor to Aux board. Repair or replace wiring harness.
		Phone cable sockets dirty on either end of cable. Clean phone cable and sockets.

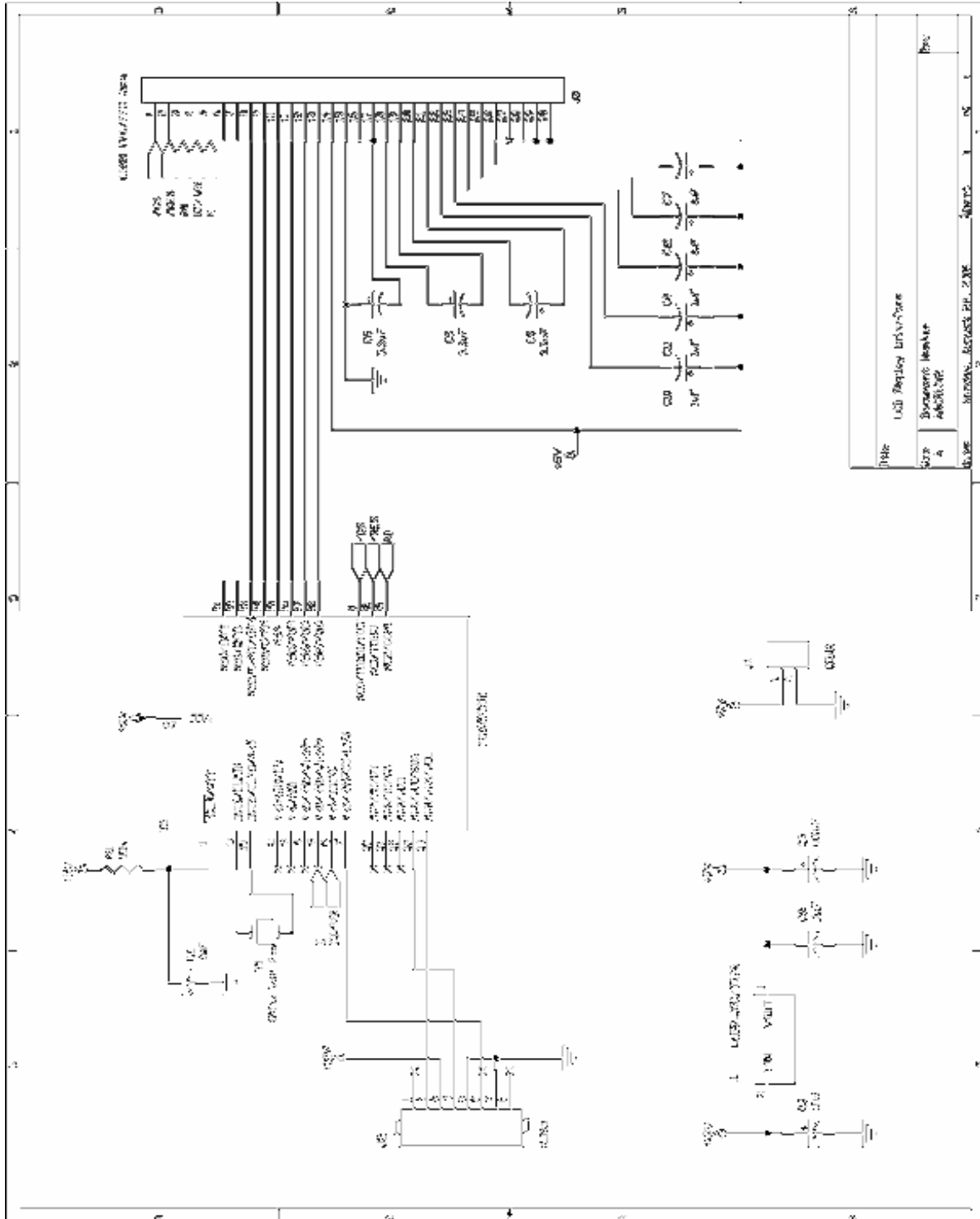

ELECTRICAL DRAWINGS

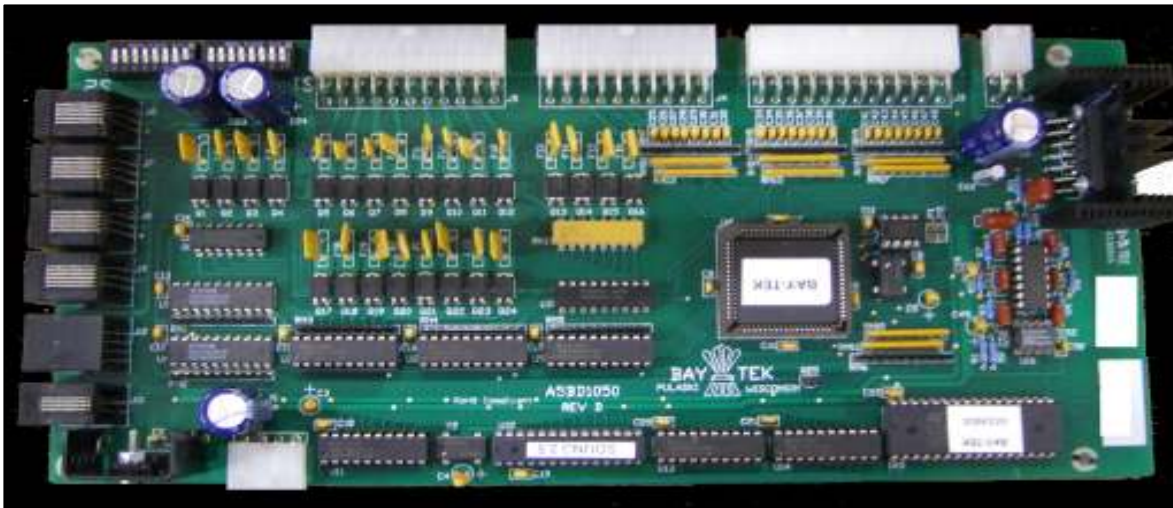

PCB DRAWING

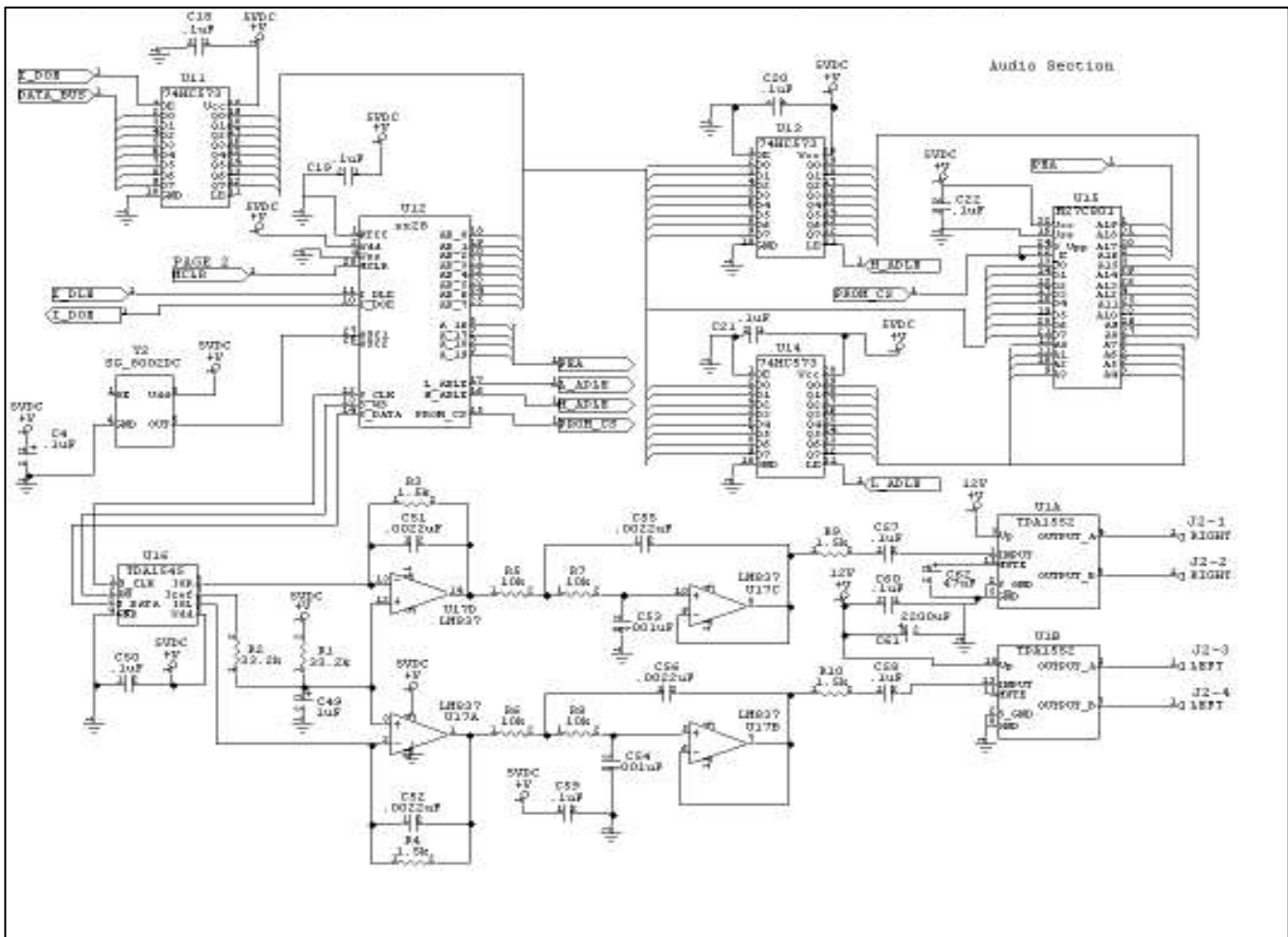

Communications - Serial EEprom

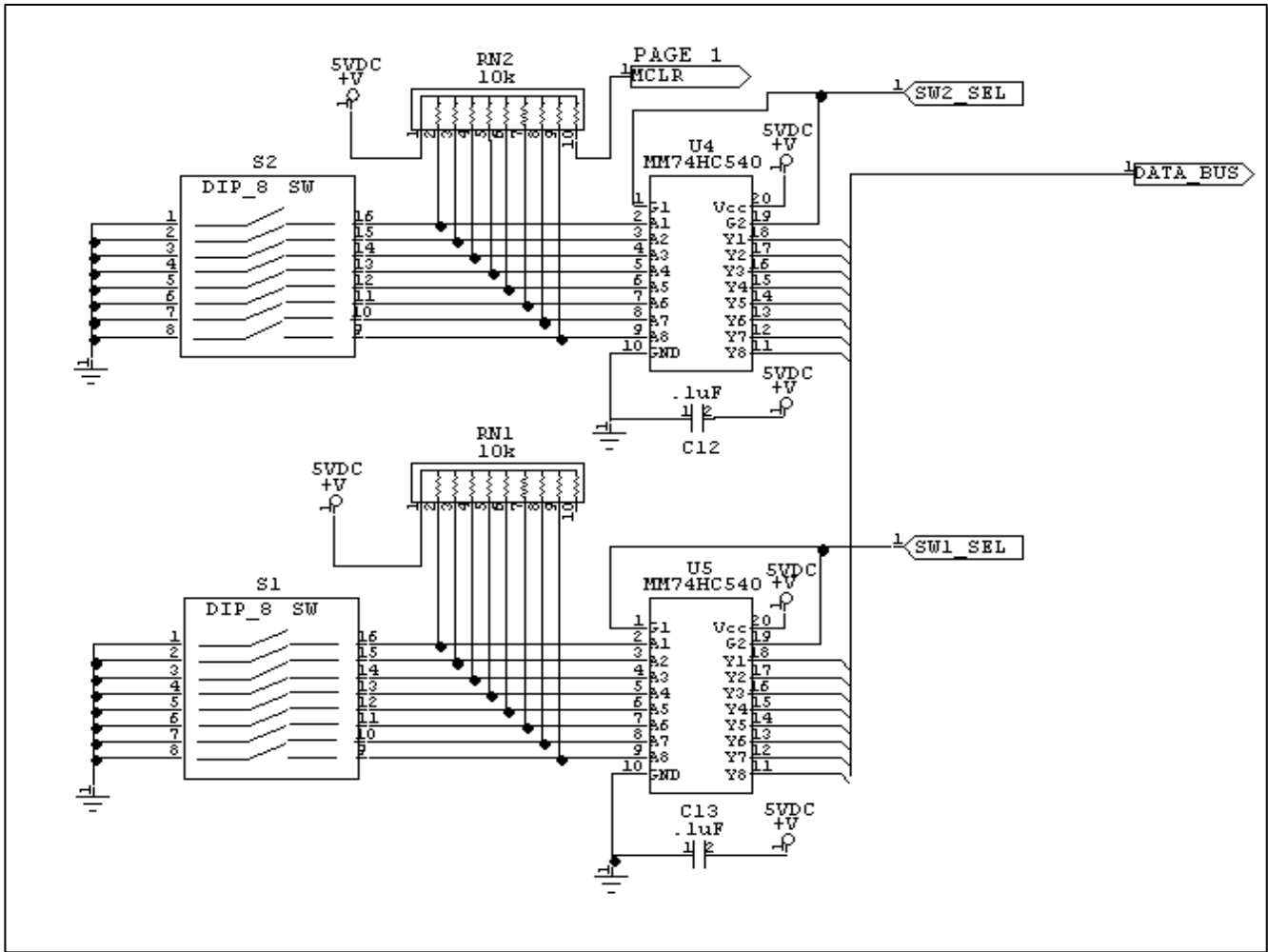

Input Section B - Inputs RE, RC

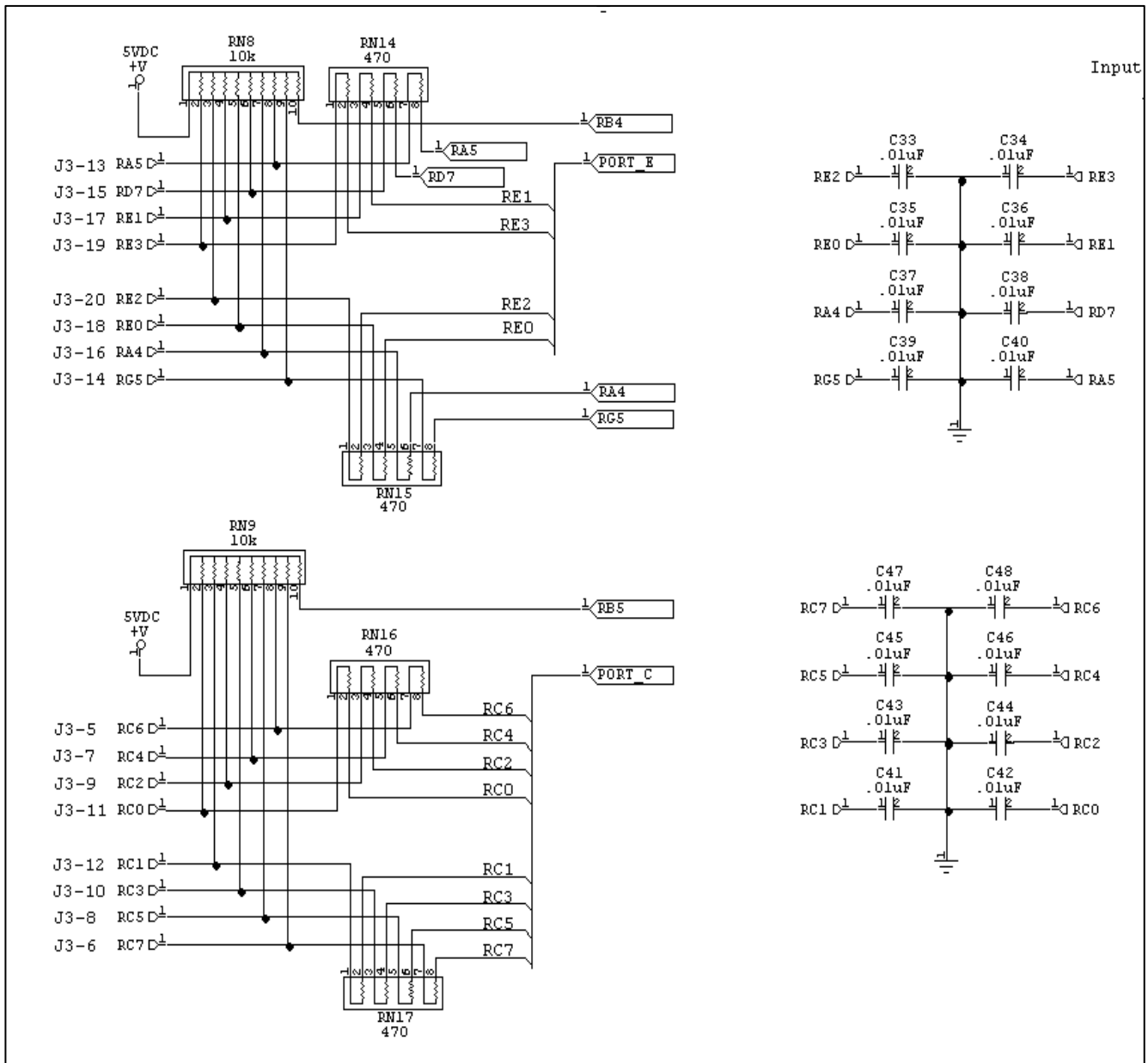

Output Section - Chase lights Q13-Q16

Output Section A
 - Chase Lights
 - Q13-16

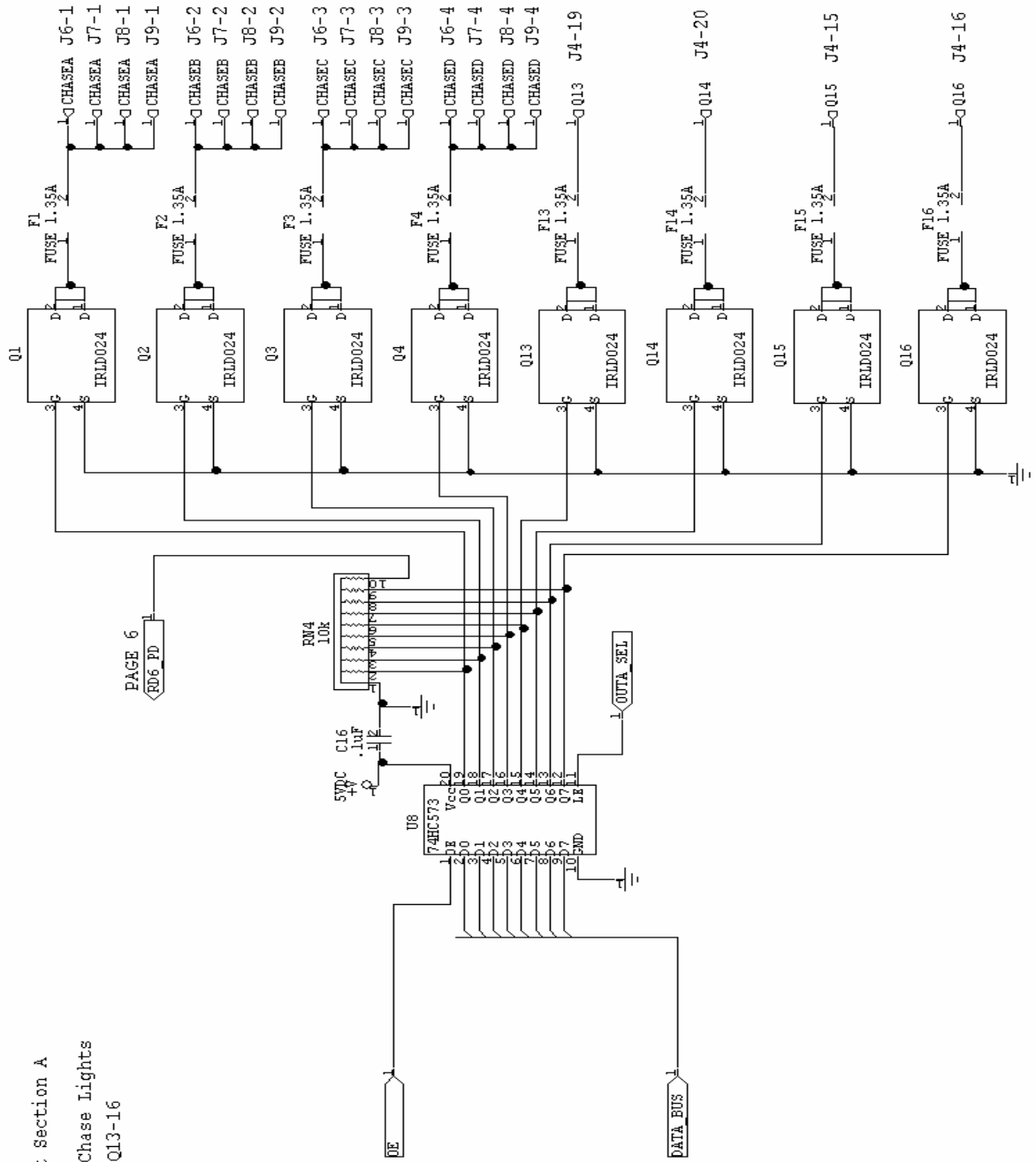

Output Section B Q17-Q24

Output Section C Q5-Q12

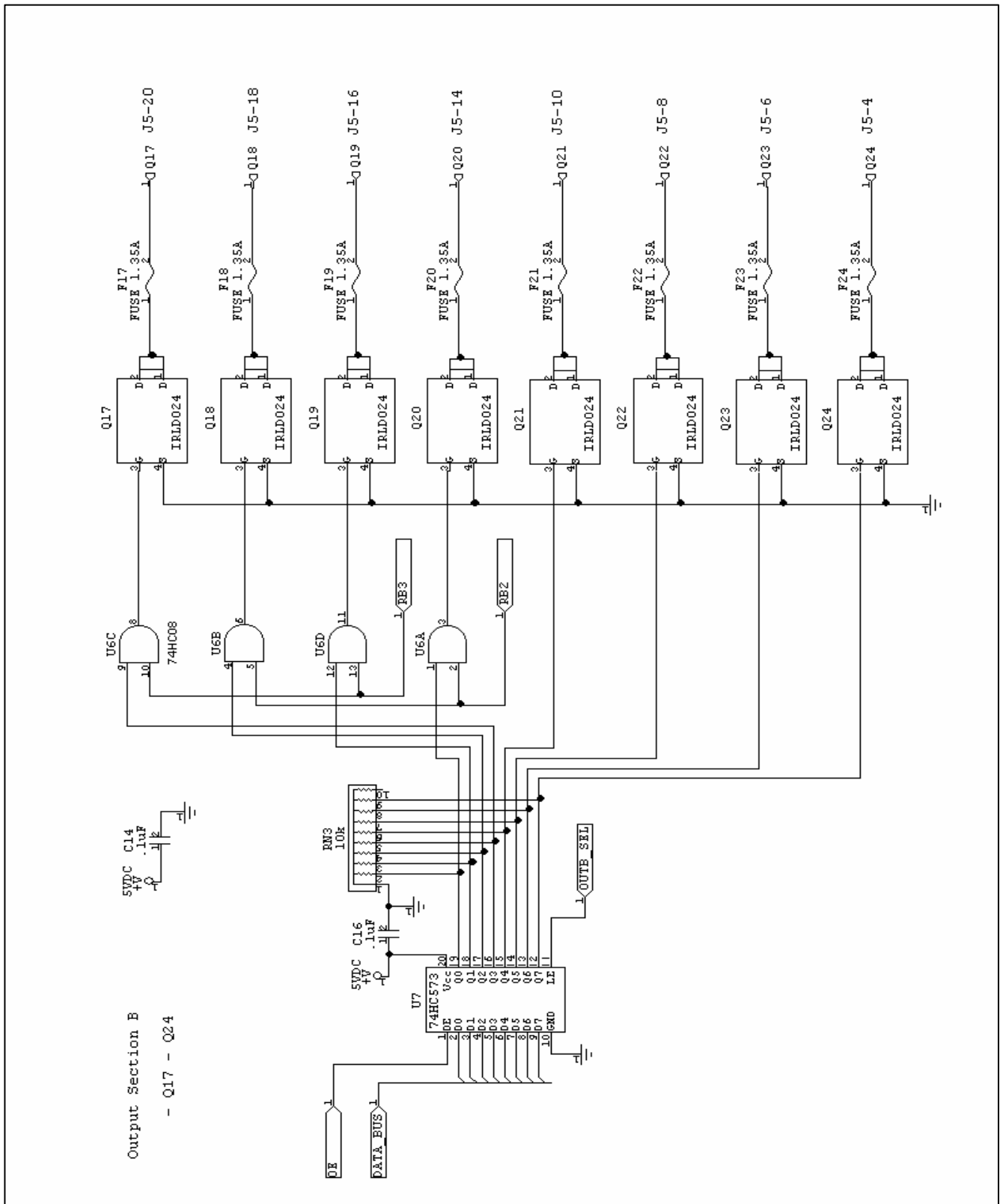

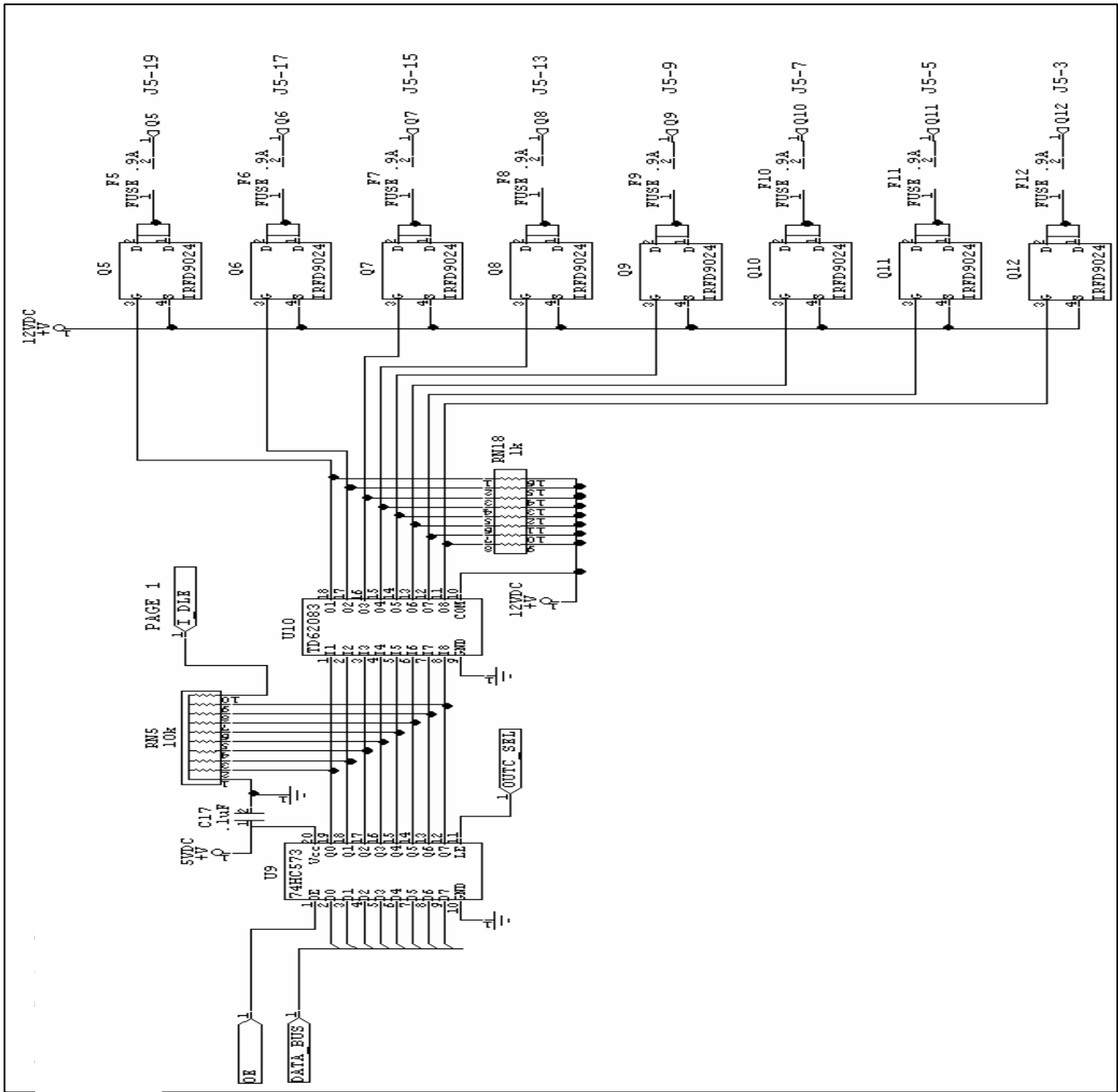

Power Section

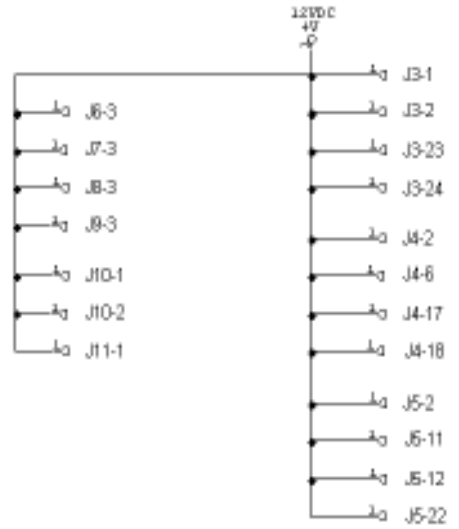
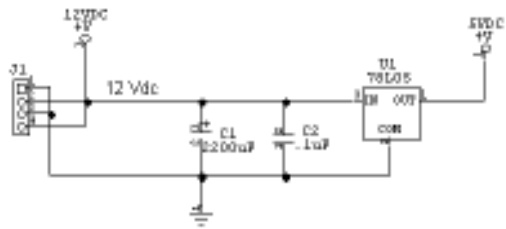

Processor Section - Input RD



Excellent customer service is very important to Bay Tek Games! We know that keeping your games in great operating condition is important to your business. When you need us, we are here to help. You can call us for free technical assistance, and you can count on us to have parts on-hand to support your game. When you do need us, it's important that you know what to expect. We offer options that fit your needs.

Electronics / Circuit Boards:

• **Repair & Return** – If you have Circuit Board issues with your Bay Tek game, you can send the board to us and we'll repair it right away. Most items sent to us are repaired and returned to you within two days. This option is your best value as we offer this fast turn-around service at the most reasonable price.

• **Advance Replacement** – If you have Circuit Board issues with your Bay Tek game, but you don't have time to send in your board in for repair, give us a call and ask for an Advance Replacement. We'll send you out a replacement board that same day (pending availability). This is your best option when you need to get your game up and running as quickly as possible! When you get your new board, just repackage the defective board in the same box and send it back to us. We make it easy by including a UPS Return-Shipping label for you to put on the box.

• **Spare Parts** – Take matters into your own hands and purchase new spare Circuit Boards for your Bay Tek games. Many of our games share the same main-board electronics. This means you can buy one set of spare electronics to support many of your Bay Tek games. Spare boards allow you to get your game up and running the quickest and provide you a valuable troubleshooting option. Call our technicians to get recommendations for what you should keep on hand for spare parts!

Technical Support:

"You" are the best tool for troubleshooting! Your abilities to understand the game and your skills to repair the game are invaluable to us! If you need help, you know you can call us. It's not easy to diagnose a game remotely by phone, but our technicians do a great job. They'll need your help to perform some troubleshooting steps and convey to them exactly what's happening with your game.

Returns & Credits:

Sometimes the issue isn't what it seemed to be. If you chose the Advance Replacement option and now need to return that circuit board, just give us a call to get Return Authorization. You will be credited for the cost of the board and charged only the bench fee for our processing and retesting that board. If you choose the Repair and Return option, we'll test your board before we begin. If no problems are found, you will only be charged the bench fee.

Note: Bench fees apply regardless of whether the repair was your choice or a recommendation from a Bay Tek Games technician. It's a small price to pay for troubleshooting the issues with your game.

You can count on our Technical Support Team for service and support!

Warranty Information

Bay Tek Games Inc. warrants to the original purchaser that the game will be free of defects in workmanship and materials for a period of (6) months from the date of installation.

Bay Tek Games Inc. will, without charge, repair or replace at it's option defective product or component parts upon notification to the factory service department.

Warranty replacement part(s) will be shipped immediately via ground service, along with a Return Material Authorized (**RMA**) number for the return of defective part(s). Defective parts must be shipped back to Bay Tek Games unless otherwise instructed.

This warranty does not apply in the event of any misuse or abuse of the product, or as the result of any unauthorized repairs or alterations. The warranty **does not** apply if the serial number decal is altered, defaced, or removed from its original position.

Should your game need servicing, determine the serial number from the decal on the back of the cabinet or the logic unit, and call **920.822.3951** or email to:

SERVICE@BAYTEKGAMES.COM

Repair of NON-Warranty Units

Should your game need servicing, determine the serial number from the decal on the back of the cabinet or the logic unit, and call **920.822.3951** or email to:

SERVICE@BAYTEKGAMES.COM

An estimate of the repair charges will be quoted to you for approval.

You can proceed in one of two ways:

1. Request the immediate shipment of advanced replacement part(s).

You will receive the part(s) with an RMA for the return of the faulty part(s). You must return the faulty parts in **14 days** to avoid additional charges.

2. Send in the defective part(s) for repair or replacement.

Please include the following information:

Name
Address
Phone Number
Serial Number
Purchase Order Number
or Signed Authorization to perform service

Repair and returned parts will be shipped back using the same mode of transportation in which they were received. Repairs are warranted (30) days from the date installed into service.

Contact Us



Fax us at
(920) 822-1496



Email us 24 hours a day at
service@bay-tek.com
Also order parts online at
www.baytekgames.com

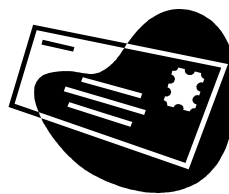

Parts can be sent to
**1077 E Glenbrook Dr
Pulaski, WI 54162**

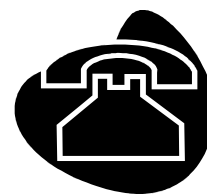

Call us M-F
8am-5pm CST at
(920) 822-3951

Repair Record



For a complete list of parts and
prices please visit:

baytekgames.com/parts



SERVICE FIRST NETWORK

We have put together our new "Service First" network to keep our customers up to date on the latest information, parts specials, upgrades, technical bulletins, and much more. If you are not on the network, sign on today!



SERVICE FIRST CONTACT INFO

Fax directly to service department
[\(920\) 822-1496](tel:(920)822-1496)

Comments / Questions:
 [\(920\) 822-3951 ext. 1101](tel:(920)822-3951)

Email :
service@baytekgames.com

Part Number	Description
A5AC9091	BILL ACCEPTER - see ATTENTION box below
AAJP9090	JUMPER CABLE, BILL ACCEPTOR, MARS
A5AR1001	LOCK ARM FOR FRONT DOOR
A5HA1001	T-HANDLE FOR FONT DOOR LOCK
A5LK1001	LOCK FOR BLACK T-HANDLE LOCK
A5LK2000	CASH BOX LOCK (631)
A5LK5001	BACK DOOR LOCK (644)
A5SR-25C	SINGLE COIN DOOR W/ 25C MECH
A5PL9097	BILL ACCEPTOR BLANKING PLATE
A5SP1437	SPEAKER
A5CA1002	WHEEL CASTER
A5CB2050	CASH BOX
A5CORD5	COMPUTER POWER CORD
A5FI9222	IN-LINE FILTER
A5LEAC001	YELLOW LENS COVER (8 PER GAME)
A5LEAC002	BLU LENS COVER (5 PER GAME)
A5LI0001	COMPACT FLORESCENT BULB
A5SC5002	BULB SOCKET
A5LIYE010	YELLOW LIGHT, MARQUEE
WSTM1316	T-MOLDING, BLK/SILVER (35 FEET PER GAME)
A5PB6900	RED MENU BUTTON
A5PBAC001	RED PUSH BUTTON, SELECT PRIZE
A5PBAC002	GREEN PUSH BUTTON, CONTINUE
A5PBAC003	YELLOW PUSH BUTTON, STOP
A5TG1300	FRONT DOOR GLASS
A5TG1301	SIDE WINDOW GLASS (2 PER GAME)
AAVFBZ001	VACUUM FORM STAR PLAYFIELD WITH BLUE LENS COVERS
A5DSPZ010	PRIZE DISPENSER SPINDLE LONG (6 PER GAME)
A5DSPZ020	PRIZE DISPENSER SPINDLE SHORT (2 PER GAME)
CIRCUIT BOARDS	
A5CBDI010	LCD DISPLAY BOARD
AACB1402	LCD INTERFACE BOARD
AACB1303	AUX BOARD, CONNECT TO GEN 5
AACB1304	LARGE PRIZE INDICATOR LIGHT BOARD (2 PER GAME)
AACB1305	TOP ROW PRIZE INDICATOR LIGHTS (2 PER GAME)
AACB1400	STAR PLAYFIELD BOARD (5 PER GAME)
AACB1401	PRIZE CHUTE SENSOR BOARD (2 PER GAME)
AACB1403	LARGE PRIZE SPINDLE LIGHTS, WHITE (2 PER GAME)
AACB1404	DOOR INTERFACE BOARD
AAMB5A	PCB
A5PS1001	POWER SUPPLY

	ATTENTION	
<p>DBA REQUIREMENTS MANUFACTURER: MEI MODEL: AE 2451 U5E or any other UL recognized DBA.</p>		

Replacement Decal List for American Idol Super Star™



A5AC1401	SUPER PRIZE ACRYLIC
A5DE1410	BLUE, LIGHT BLOCKING PLEXI
A5DE1414	TOP SPINDLE BOARD DECAL, INSIDE



